



**HAYDARI MADRASAH**  
**(NAIROBI)**

**QUR'AN READING**

**CLASS ONE**

**(Age 4 yrs)**

Name: \_\_\_\_\_



**HAYDARI MADRASAH**  
**(NAIROBI)**

**QUR'AN READING**

**CLASS 1 - Age 4 yrs**

**NO COPYRIGHT**

**September, 2020**

These manuals on Qur'an reading, have been prepared to especially assist parents, teachers and students, who wish to teach and/or learn to recite the Holy Qur'an.

Please note that there is **NO COPYRIGHT** in regards to the reproducing of these manuals as long as the aim above is being fulfilled. Therefore there is **NO** requirement of a written permission from Haydari Madrasah Nairobi for reproducing this book for Madaris or personal use.

In case only part of this manual is reproduced, or the material therein edited in any manner, we request that any and all references to Haydari Madrasah Nairobi, be removed.

We do request however, that the manuals reproduced should **NOT** be for profit / commercial purposes. The cost of reproducing this manual may be recovered.

The Qur'an Reading Department  
Haydari Madrasah (Nairobi)  
hmn@saaj.co.ke

## CONTENTS: Qur'an Reading Syllabus

<u>SUBJECT</u>	<u>DETAILS</u>	<u>PAGE</u>
Surahs Memorisation  <b><u>KG Revision</u></b>	Surah Al-Fatehah (Surah no: 1) Surah Al-Ikhlās (Surah no: 112) Surah Al-Asr (Surah no: 103) Surah Al-Kawthar (Surah no: 108)	
Surahs Memorisation  <b><u>Class One</u></b>	<b>MID YEAR</b> - Surah An-Naas (No: 114) Surah Al-Falaq (No: 113)	7 8
	<b>END YEAR</b> - Surah Al-Feel (No: 105) Surah An-Nasr (No: 110)	9 10
Kalema	Recitation of full Kalema with meaning	11
Dua e Faraj	Dua for the safety of our 12 <sup>th</sup> Imam	12
Short Duas	Dua at the time of Distress	13
	Dua before Sleeping	14
Islamic Phrases <b><u>KG Revision</u></b>	Islamic Phrases and what they mean: Bismillah, Salaam/Wa Alaikum Salaam, Shukran, Jazakallah, Alhamdulillah, MashaAllah, Afwan, Salawaat	15
Islamic Phrases <b><u>Class One</u></b>	Islamic Phrases and what they mean: Fi Amaanillah and Subhaanallah	16
The Holy Qur'an	How Allah's Message came to us	17
	How to Respect the Special Book	18

**CONTENTS: Syllabus for Class One.....continued**

<b><u>SUBJECT</u></b>	<b><u>DETAILS</u></b>	<b><u>PAGE</u></b>
Motor Control	Motor Control Activities	19 - 25
Revision <b><u>KG Revision</u></b>	Pronunciation and the First 10 letters Alif to Re	26 - 36
Introduction	Pronunciation and the rest of the Arabic Alphabet	37
Ze, Sin & Shin	Individual introduction + Reading & Written Activities	38 - 55
Saad, Dhaad, Tta & Zhe	Individual introduction + Reading & Written Activities	56 - 76
Ayn, Ghayn, Fe & Qaf	Individual introduction + Reading & Written Activities	77 - 97
Kaf, Lam, Mim & Nun	Individual introduction + Reading & Written Activities	98 - 118
Waw, Hai, Hamza, Lam Alif & Ye	Individual introduction + Reading & Written Activities	119 - 138
Revision Class KG & One	What we have learnt	139 - 161
Certificate	Congratulations you did it 	163

## SURAHS MEMORISATION - from KG to CLASS 3

### The Holy Prophet (SAW) has said:

"The number of levels (stages) in Heaven is (equivalent to) the number of verses in the Qur'an (6236). Thus, when a reciter of the Qur'an enters into Heaven, it will be said to him: 'Go up one level for every verse that you can recite.' Thus, none will be in a higher level than the one who has memorized the entire Qur'an."

**[Biharul Anwar, Volume 92 Page 22]**

The table below classifies how the student will be tested for Surah Memorisation every year, by the Holy Madrasah. It will be to the child's advantage if parents prepare them ahead of time.

The chart from KG to Class 12 has been designed to cover the whole of the 30<sup>th</sup> Sipara (Juz Amma).

Some surahs have been repeated for testing purposes. Surahs which are required in our day to day lives, like Surah Jumuah and Surah Mulk have been added.

Parents are advised to train their child(ren) to memorise by reading from the Qur'an rather than only learning the Surah by heart.

When the child reads then memorizes, they learn the formation of the text, and they learn where the extra pull is required. It also ingrains the Surah well into their minds.

## EFFECTIVE METHODS OF MEMORISATION

- 1) Teach an Ayah a day. This is a tried and tested method, where even when the student is ready to learn more, we restrain and teach only that one ayah (with meaning if one prefers). The next day a second ayah and so on. In a week the student has learnt 7 ayaat. This is stress free and an easy method.
- 2) Get help from YouTube. Type in the Surah Name and numerous options will come up. You can select your preferable reciter (we recommend Mishary Al Afasy) and the student can listen, read and learn at the same time. This will help build in the right makharij as well.
- 3) Download the App called Memorize. This is preferred by the older students for self-study.

### SURAHS MEMORISATION - from KG to CLASS 3

<u>CLASS</u>	<u>MID - YEAR</u>	<u>END - YEAR</u>
KG	Surah Al-Fatihah (1) Surah Al-Ikhlash (112)	Surah Al-Kawthar (108) Surah Al-Asr (103)
1	Surah Al-Nas (114) Surah Al-Falaq (113)	Surah Al-Fil (105) Surah Al-Nasr (110)
2	Surah Al-Qadr (97)	Surah Al-Lahab (111) Surah Al-Quraysh (106)
3	Surah Al-Tin (95)	Surah Al-Kafirun (109)

**SURAHS TO BE MEMORISED (MID - YEAR)****Surah An-Naas (114) AND Surah Al-Falaq (113)**

- ❖ Reciting this Surah at night, ensures safety from the Jin and Shaitan.
- ❖ This Surah can be recited on any part of the body that is in pain, and the pain will be relieved.

**SURAH AN-NAAS****(THE MEN)**

SURAH NO: 114

REVEALED IN  
MECCA

HAS 6 AYAT

بِسْمِ اللَّهِ الرَّحْمَنِ الرَّحِيمِ

قُلْ أَعُوذُ بِرَبِّ النَّاسِ ﴿١﴾

مَلِكِ النَّاسِ ﴿٢﴾

إِلَهِ النَّاسِ ﴿٣﴾

مِنْ شَرِّ الْوَسْوَاسِ الْخَنَّاسِ ﴿٤﴾

الَّذِي يُوسْوِسُ فِي صُدُورِ النَّاسِ ﴿٥﴾

مِنَ الْجِنَّةِ وَالنَّاسِ ﴿٦﴾



**SURAHS TO BE MEMORISED (MID - YEAR)****Surah An-Naas (114) AND Surah Al-Falaq (113)**

The Holy Prophet (SAW) has said: Whoever recites this Surah in the month of Holy Ramadhan, in any of his prayers, it is as if he has fasted in Mecca and he will get the reward for performing Hajj and Umrah.

**SURAH AL-FALAQ****(THE DAWN)**

SURAH NO: 113

REVEALED IN  
MECCA

HAS 5 AYAT

بِسْمِ اللَّهِ الرَّحْمَنِ الرَّحِيمِ

قُلْ أَعُوذُ بِرَبِّ الْفَلَقِ ﴿١﴾

مِنْ شَرِّ مَا خَلَقَ ﴿٢﴾

وَمِنْ شَرِّ غَاسِقٍ إِذَا وَقَبَ ﴿٣﴾

وَمِنْ شَرِّ النَّفَّاثَاتِ فِي الْعُقَدِ ﴿٤﴾

وَمِنْ شَرِّ حَاسِدٍ إِذَا حَسَدَ ﴿٥﴾

**SURAHS TO BE MEMORISED (END - YEAR)****Surah Al-Feel (105) AND Surah An-Nasr (110)**

- ❖ Reciting this Surah keeps you safe from enemies.
- ❖ Any difficulties and problems are solved quickly.
- ❖ Recitation of this Surah helps in remaining safe from evil and bad leaders.

**SURAH AL-FEEL (THE ELEPHANT)**

SURAH NO: 105

REVEALED IN  
MECCA

HAS 5 AYAT

بِسْمِ اللَّهِ الرَّحْمَنِ الرَّحِيمِ

أَلَمْ تَرَ كَيْفَ فَعَلَ رَبُّكَ بِأَصْحَابِ الْفِيلِ ﴿١﴾

أَلَمْ يَجْعَلْ كَيْدَهُمْ فِي تَضْلِيلٍ ﴿٢﴾

وَأَرْسَلَ عَلَيْهِمْ طَيْرًا أَبَابِيلَ ﴿٣﴾

تَرْمِيهِمْ بِحِجَارَةٍ مِنْ سِجِّيلٍ ﴿٤﴾

فَجَعَلَهُمْ كَعَصْفٍ مَأْكُولٍ ﴿٥﴾

**SURAHS TO BE MEMORISED (END - YEAR)****Surah Al-Fil (105) AND Surah An-Nasr (110)**

- ❖ The recitation of this Surah brings Allah's Mercy and Forgiveness.
- ❖ The person who recites this Surah in his Wajib prayers, will be victorious over his enemies and his prayers are accepted.

**SURAH AN-NASR****(THE HELP)**

SURAH NO: 110

REVEALED IN  
MEDINA

HAS 3 AYAT

بِسْمِ اللَّهِ الرَّحْمَنِ الرَّحِيمِ

إِذَا جَاءَ نَصْرُ اللَّهِ وَالْفَتْحُ ﴿١﴾

وَرَأَيْتَ النَّاسَ يَدْخُلُونَ فِي دِينِ اللَّهِ أَفْوَاجًا ﴿٢﴾

فَسَبِّحْ بِحَمْدِ رَبِّكَ وَاسْتَغْفِرْهُ ۖ إِنَّهُ كَانَ تَوَّابًا ﴿٣﴾

## K A L E M A

بِسْمِ اللَّهِ الرَّحْمَنِ الرَّحِيمِ

لَا إِلَهَ إِلَّا اللَّهُ مُحَمَّدٌ رَّسُولُ اللَّهِ عَلِيُّ وَوَلِيُّ اللَّهِ

وَصِيُّ رَسُولِ اللَّهِ وَخَلِيفَتَهُ بِلَا فَصْلٍ

### TRANSLITERATION

LA ILAHA ILLALLAH

MUHAMMADUR RASULALLAH

ALI YUN WALI YULLAH, WASI YUN RASULALLAH

WA KHALIIFATAHU BILAA FASL

### TRANSLATION

There is No god but Allah

Muhammad is his Messenger

Ali is his Chosen One, He is the Helper of the Prophet

And He is the First Khalifa of the Prophet

## SHORT DUA - DUA E FARAJ

اللَّهُمَّ كُنْ لِوَلِيِّكَ الْحُجَّةِ بْنِ الْحَسَنِ صَلَواتِكَ عَلَيْهِ  
 وَعَلَى آبَائِهِ فِي هَذِهِ السَّاعَةِ وَفِي كُلِّ سَاعَةٍ وَلِيًّا  
 وَحَافِظًا وَقَائِدًا وَنَاصِرًا وَدَلِيلًا وَعَيْنًا حَتَّى تُسَكِّنَهُ  
 أَرْضَكَ طَوْعًا تَتَّبِعُهُ فِيهَا طَوِيلًا

### TRANSLITERATION:

Allaahumma kulle-Waliyyekal Hujjatibnil Hasan, Salawaatuka A'layhe Wa A'laa Aaabaa-Ehi, Fee Haazehis Saa-A'te, Wa Fee Kulle Saa-A'tin, Waliyyawn Wa Haafezan Wa Qaa-Edan Wa Naaseran, Wa Daleelan Wa A'ynan, Hattaa Tuskenahu Arzaka Taw-A'n, Wa Tomatte-A'hu Feehaa Taweelaa.

### TRANSLATION:

O Allah! Protect your Vicegerent Hujjat (The Proof), son of Hassan and send Salutations upon him, and his ancestors, now as well as at all times,

(as our) Imam, Guardian, Supporter, and Guide until such time when you Bestow upon him the honour of heading the (Divine) Government.

And let the people be delighted in his reign, by bestowing Success, and by extending his reign.

## SHORT DUAS

### DUA AT THE TIME OF DISTRESS

حَسْبِيَ اللَّهُ وَنِعْمَ الْوَكِيلُ

"Has-bi Yal-Laahu wa ni' - mal wa-keel"

Meaning:

Allah (SWT) is sufficient for me  
and He is the Best Helper.



☆ ☆ ☆ ☆ ☆ ☆ ☆ ☆ ☆ ☆

☆ ☆ ☆ ☆ ☆ ☆ ☆ ☆ ☆ ☆

SHORT DUAS

☆ ☆ ☆ ☆ ☆ ☆ ☆ ☆ ☆ ☆

☆ ☆ ☆ ☆ ☆ ☆ ☆ ☆ ☆ ☆

DUA BEFORE SLEEPING

☆ ☆ ☆ ☆ ☆ ☆ ☆ ☆ ☆ ☆

☆ ☆ ☆ ☆ ☆ ☆ ☆ ☆ ☆ ☆

اللَّهُمَّ بِاسْمِكَ أَمُوتُ وَأَحْيَا

☆ ☆ ☆ ☆ ☆ ☆ ☆ ☆ ☆ ☆

☆ ☆ ☆ ☆ ☆ ☆ ☆ ☆ ☆ ☆

"Allahumma Bismika amutu wa ahyaa"

☆ ☆ ☆ ☆ ☆ ☆ ☆ ☆ ☆ ☆

☆ ☆ ☆ ☆ ☆ ☆ ☆ ☆ ☆ ☆

Meaning:

☆ ☆ ☆ ☆ ☆ ☆ ☆ ☆ ☆ ☆

☆ ☆ ☆ ☆ ☆ ☆ ☆ ☆ ☆ ☆

O Allah (SWT) with your name I die and I live

☆ ☆ ☆ ☆ ☆ ☆ ☆ ☆ ☆ ☆



## ISLAMIC PHRASES AND WHAT THEY MEAN

### REVISION FROM CLASS KG

Bismillahir Rahmaanir Rahim	In the name of Allah, the Most Kind, the Most Merciful
As Salaamu Alaikum Wa Rahmatullah Wa Barakatuhu	May the Mercy, Peace and Blessings of Allah be upon You
Wa Alaikum Salaam Wa Rahmatullah Wa Barakatuhu	And may the Peace, Mercy and Blessings of Allah be upon You
Jazakallahu Khair	May Allah reward you with good"
Shukraan Lillah	Thank you Allah
Alhamdullilah	All praise is due to Allah
Yar Hamuk Allah	May Allah have Mercy on you
Masha Allah	Whatever Allah Wills
Afwan	You are Welcome
Allahumma Salli Alaa Muhammadin Wa Ale Muhammad (Salawat)	O Allah, send Your Blessing on The Holy Prophet Muhammad (SAW) and his family



## ISLAMIC PHRASES AND WHAT THEY MEAN

- 1.) When departing from someone,  
we say:

"Fi Amaan Allah" Meaning:

"In the trust of Allah"



- 2.) When we praise Allah, we say:

"Alhamdulillah" Meaning:

"All praise is due to Allah"

**Remember:** "Alhamdulillah" can also be said when we sneeze

- 3.) When we see Allah's creation we say:

"Subhaanallah" Meaning: "Glory be to Allah"

We see the bounties that Allah has given us and everything that he has created. We say Glory be to Him (it is like saying WOW)

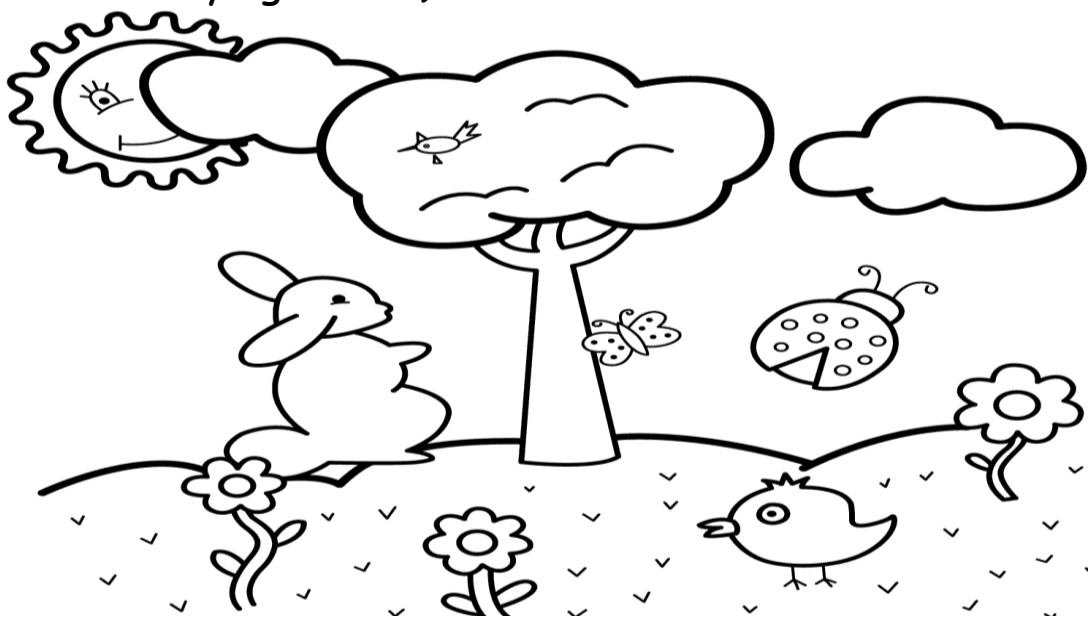

## HOW THE HOLY QUR'AN CAME TO US

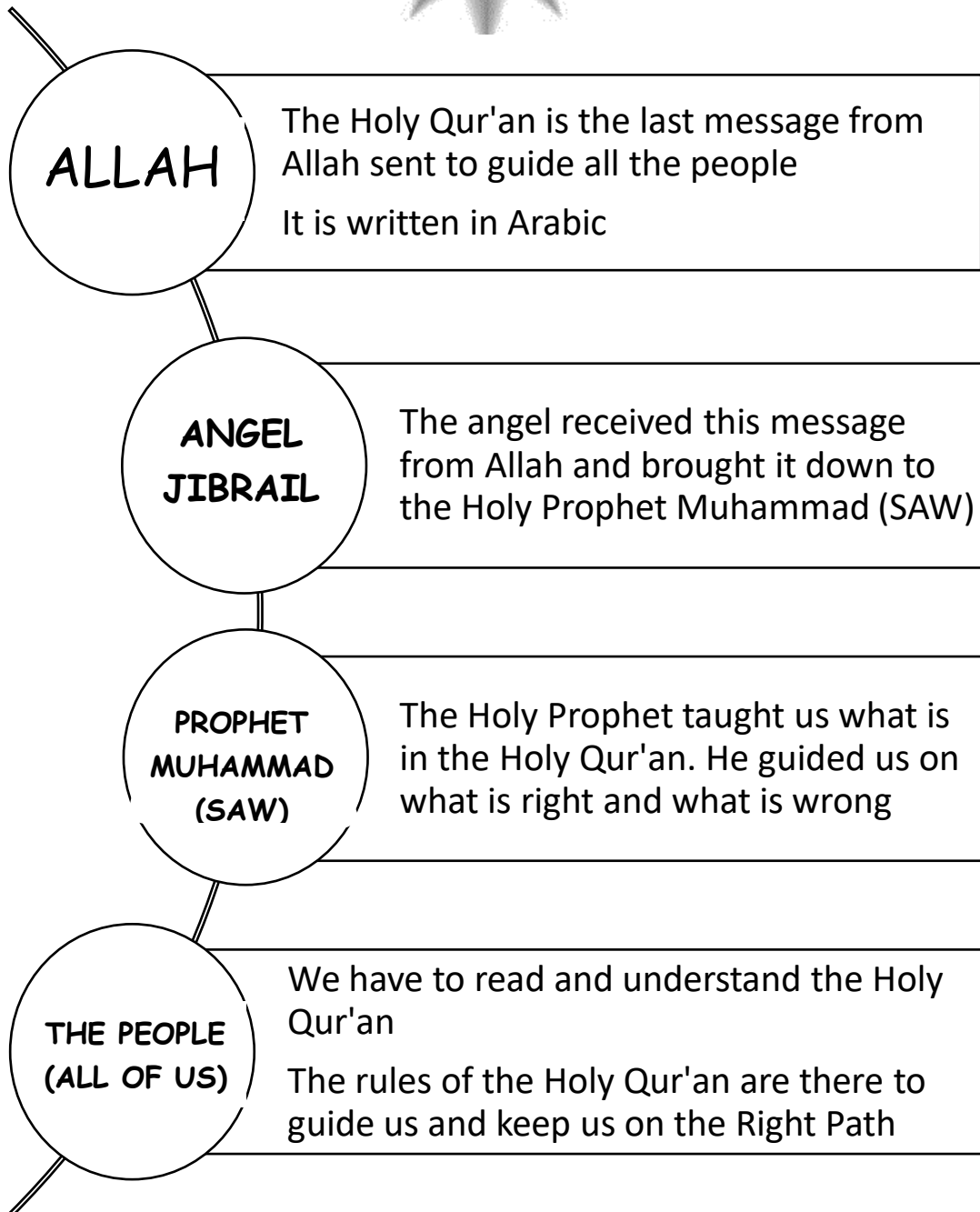

## HOW TO RESPECT THE HOLY QUR'AN



Always recite the Holy Qur'an with a very sweet and beautiful voice.

We should NOT place anything on top of the Holy Qur'an, not even other books.

We can place copies of the Qur'an on top of each other.

When reciting the Holy Qur'an, it is better to face the Qiblah and to sit with respect.



# MOTOR CONTROL

Exercises 1 - 6 in the following pages have been designed to assist the child in his/her handwriting skills.

Connecting the lines or the dots, using the Eye-Hand co-ordination will assist in establishing their motor control and movement in making the formation of the letters.

Make sure of the following:

- 1.) The correct sitting Posture of the body is important. The child should be comfortable
- 2.) The grip of the Pencil is also important. In the initial stages, parents/teachers should assist the child in the movement over the lines/dots. This will help in the co-ordination of the eye-hand-pencil connection.

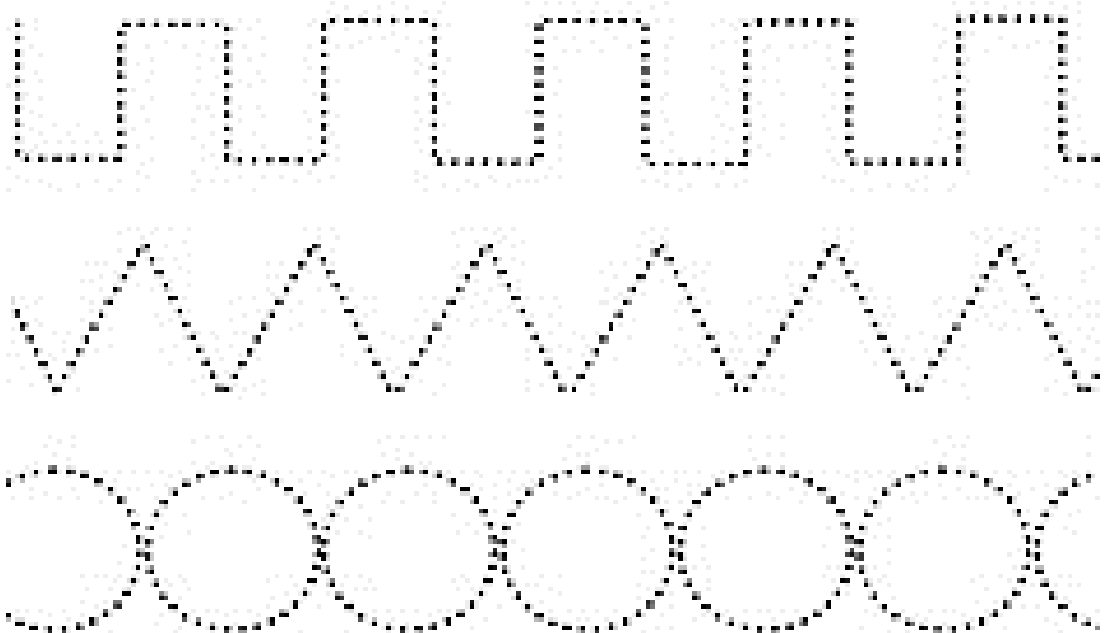

## EXERCISE 1: MOTOR CONTROL ACTIVITY

Make the pattern by joining the dots

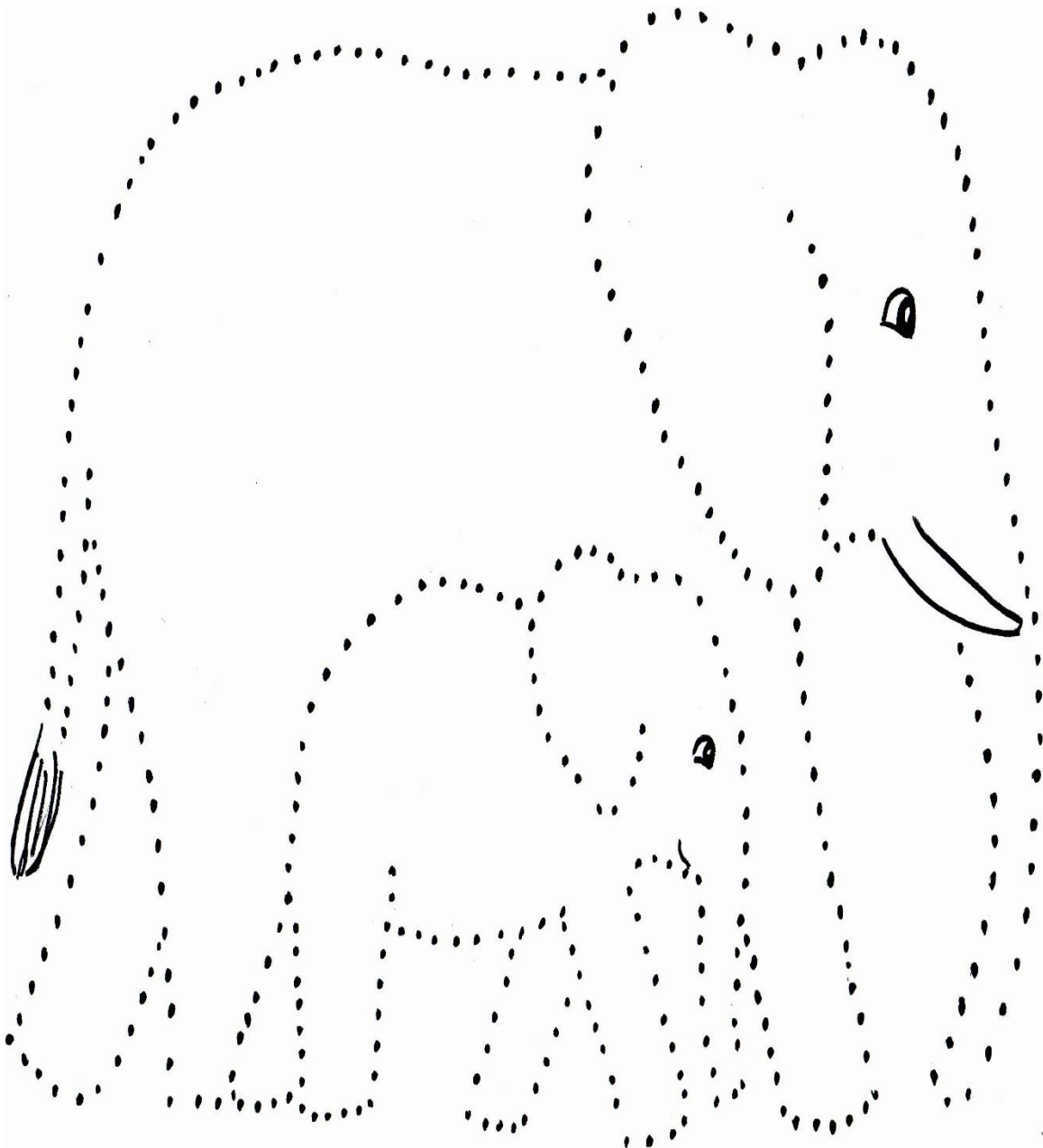

EXERCISE 2: MOTOR CONTROL ACTIVITY

Make the pattern by joining the dots

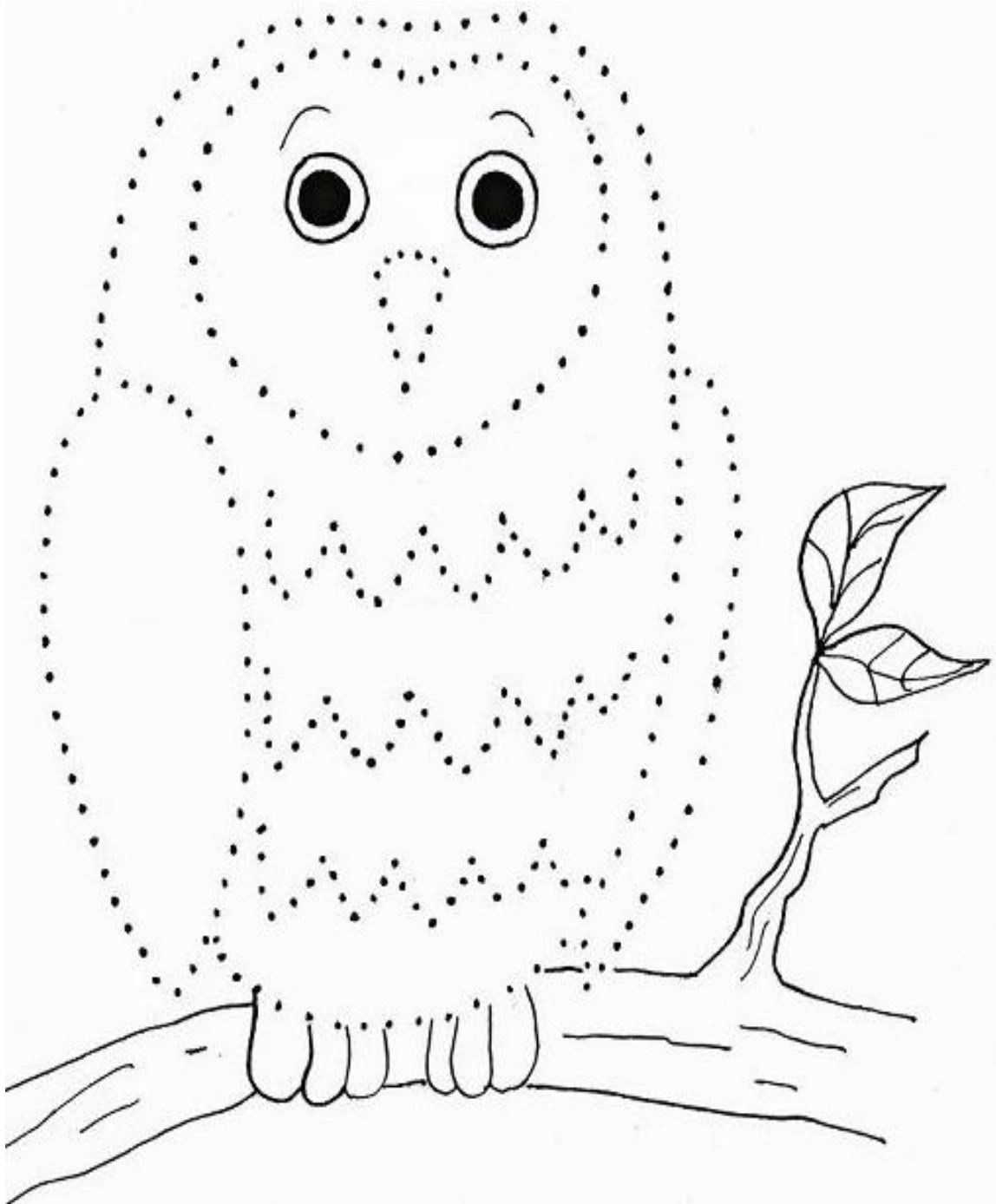

EXERCISE 3: MOTOR CONTROL ACTIVITY

Make the pattern by joining the dots

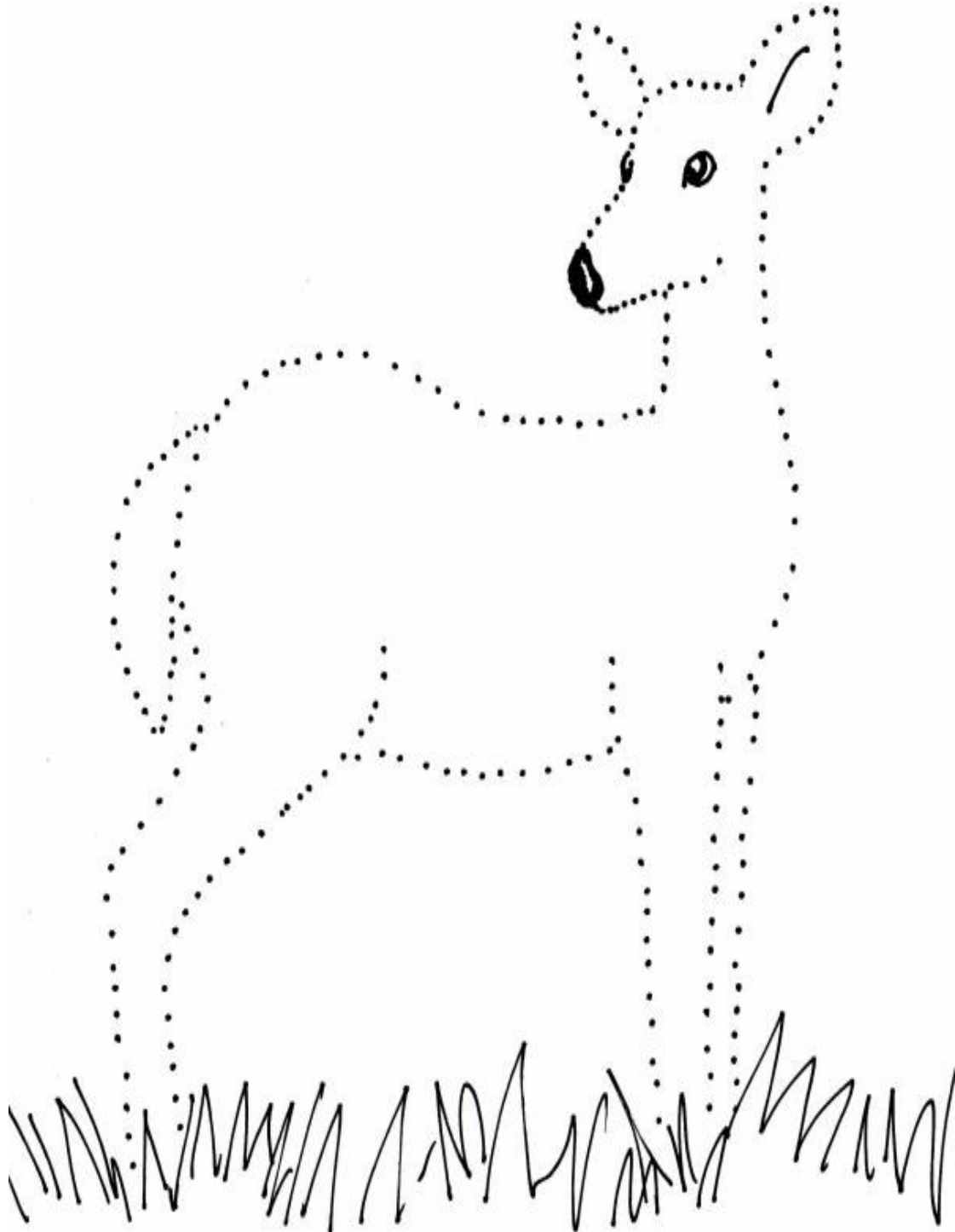

EXERCISE 4: MOTOR CONTROL ACTIVITY



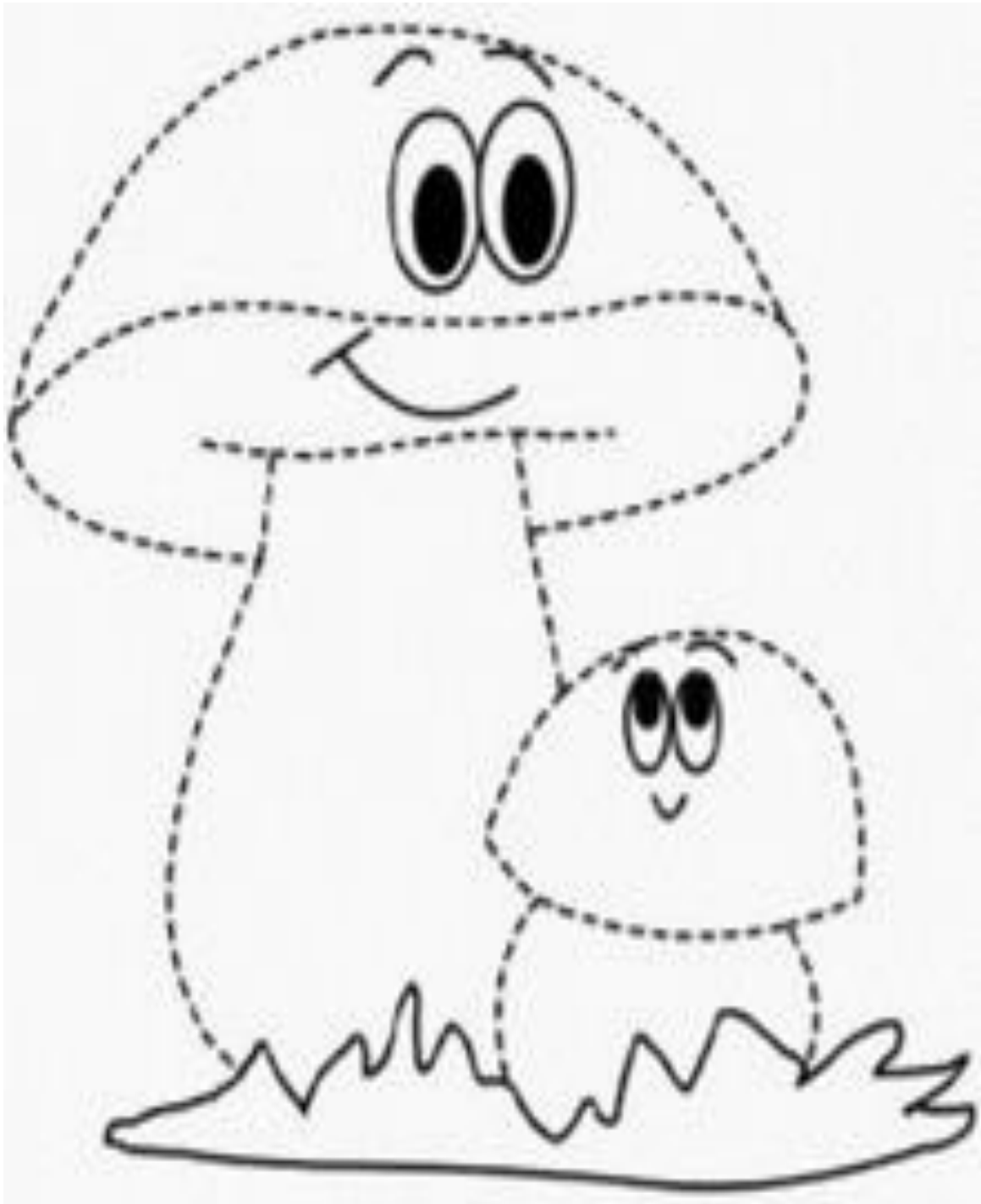



Make the pattern by joining the dots



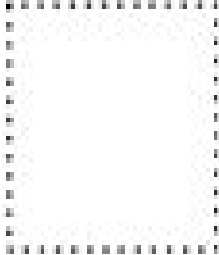

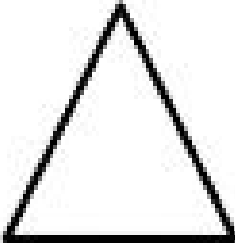
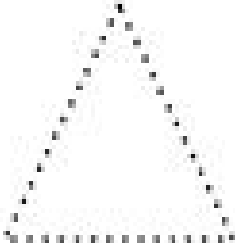
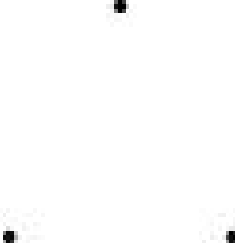
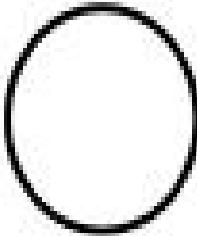
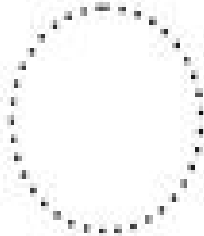
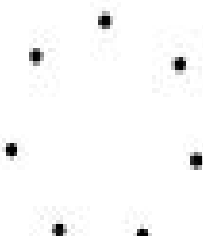
# EXERCISE 5: MOTOR CONTROL ACTIVITY

Make the pattern by joining the dots

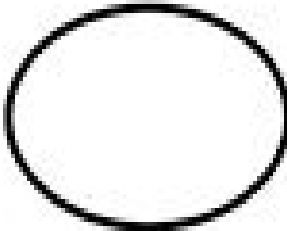
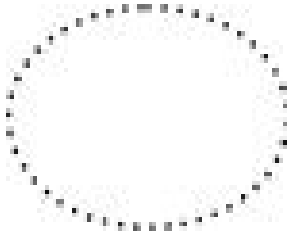
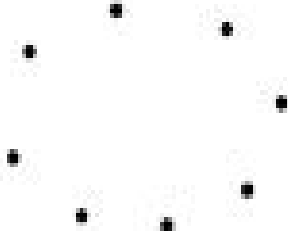
EXERCISE 6: MOTOR CONTROL ACTIVITY

Make the pattern by joining the dots



## LETTER RECOGNITION PRACTICE

### READING & WRITING OF LETTERS

Below are numerous exercises which will aid the student to recognize the letters in a gradual manner. The recognition system highlights only a few letters at a time. This will help to reinforce what has already been taught before, but ensures that when the child goes towards further chapters, this recognition is complete.











Later on we have exercises where all the letters are mixed and the child should be able to identify these letters and say them with the right Makharij, with good speed and NO assistance by the parent/teacher. When this stage is fully accomplished, feel free to go ahead to other chapters.

### TEACHING METHOD:







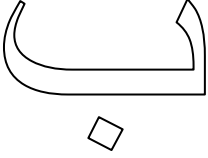

- 1.) Write and pronounce the letter. The student should repeat the letter after you.
- 2.) Allow the child to read and identify the letter from the table.
- 3.) When the child is comfortable with the identification table and is aware of each letter and how it is to be pronounced, then proceed to the writing and colouring exercises.

## KG CLASS REVISION

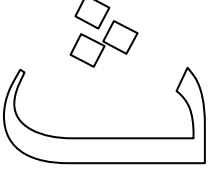
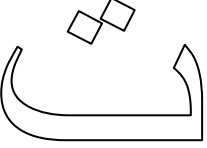
### INTRODUCTION TO FIRST 10 ALPHABETS ALIF TO RE - LETTER NAMES & SOUNDS

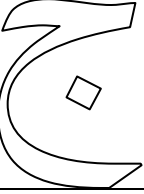
		
Te (ta)	Be (ba)	Alif (a - Light)
		
Hai (ha - Light)	Jim (ja)	The (th)
		
Dhal (dh)	Dal (da)	Khai (kh)
		
	Re (ra)	

**EXERCISE 7: LETTER RECOGNITION****Write over the letter**







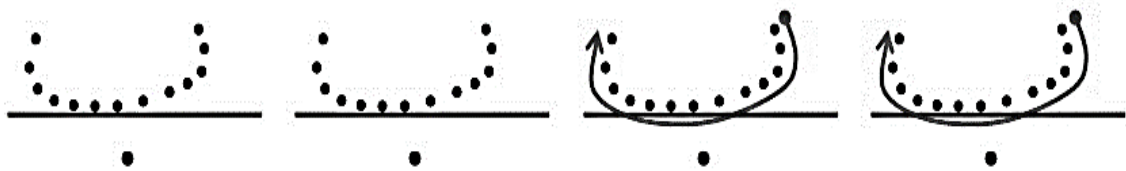

	
	
	
	
	

EXERCISE 8: LETTER RECOGNITION and WRITING



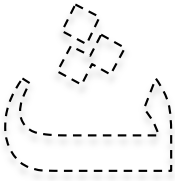

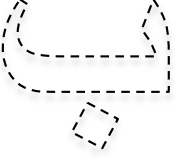





Join the dots and write the letter



EXERCISE 9: READING EXERCISERECOGNISING LETTERS ا TO ث (ALIF - THE)

Read and identify the alphabets			
			
The (th)	Te (ta)	Be (ba)	Alif (a-Light)
			

EXERCISE 10: READING EXERCISE

EXERCISE 11: LETTER RECOGNITION and WRITING

Join the dots and write the letter



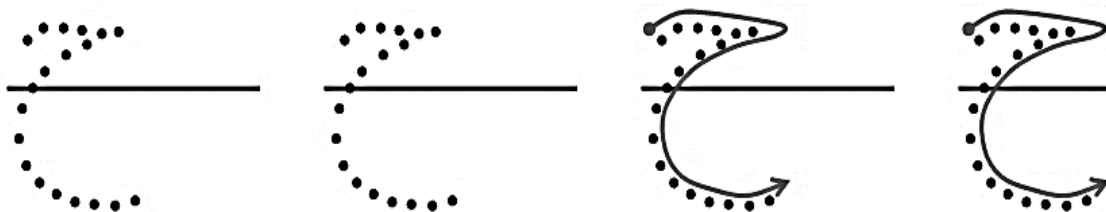
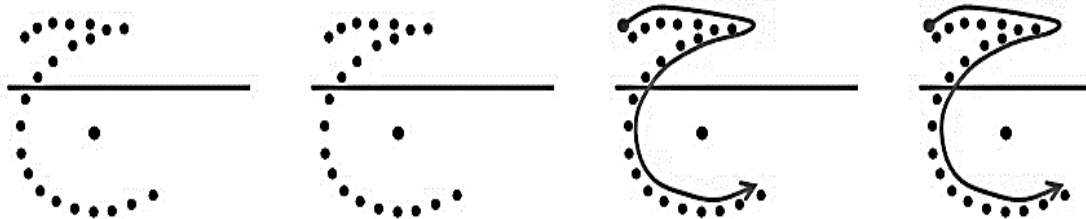

EXERCISE 12: READING EXERCISERECOGNISING LETTERS ج TO خ (JIM - KHAI)

Read and identify the alphabets

Khai (kh)	Hai (ha - Light)	Jim (ja)

EXERCISE 13: READING EXERCISE

EXERCISE 14: LETTER RECOGNITION and WRITING

Join the dots and write the letter

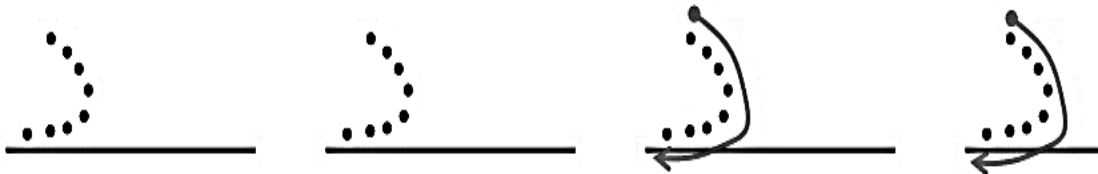
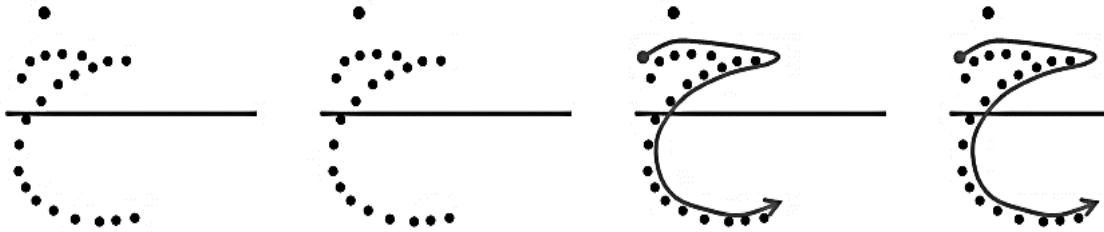

EXERCISE 15: READING EXERCISERECOGNISING LETTERS ر TO د (DAL - RE)

Read and identify the alphabets		
Re            (ra)	Dhal            (dh)	Dal            (da)

EXERCISE 16: READING EXERCISE

ذ	ا	ر	د
ذ	ح	خ	ب
ذ	ر	ث	ا

EXERCISE 17: LETTER RECOGNITIONCircle the correct matching letter

ث	ث	ا	=	ا
ا	ب	ث	=	ب
ث	ب	ث	=	ث
ث	ث	ب	=	ث
ج	خ	ب	=	ج

EXERCISE 18: LETTER RECOGNITIONCircle the correct matching letter

ا	ح	ت	=	ح
ت	ح	خ	=	خ
ب	ر	ج	=	ر
ا	ذ	ر	=	ذ
ذ	ر	ح	=	ر

# CLASS 1 - Rest of the Alphabet

## INTRODUCTION TO THE ALPHABETS ZE TO YE

### Letters and Sounds

Dhaad (dha)	Saad (ssa)	Shin (sh)	Sin (sa)	Ze (za)
Fe (fa)	Ghayn (gha)	Ayn (a - heavy)	Zhe (zh)	Tta (tta)
Nun (na)	Mim (ma)	Lam (La)	Kaf (ka)	Qaf (Qa)
Ye (ya)	Hamza (a)	Lam Alif (Laa)	Hai (ha - heavy)	Waw (wa)

EXERCISE 19: LETTER RECOGNITION

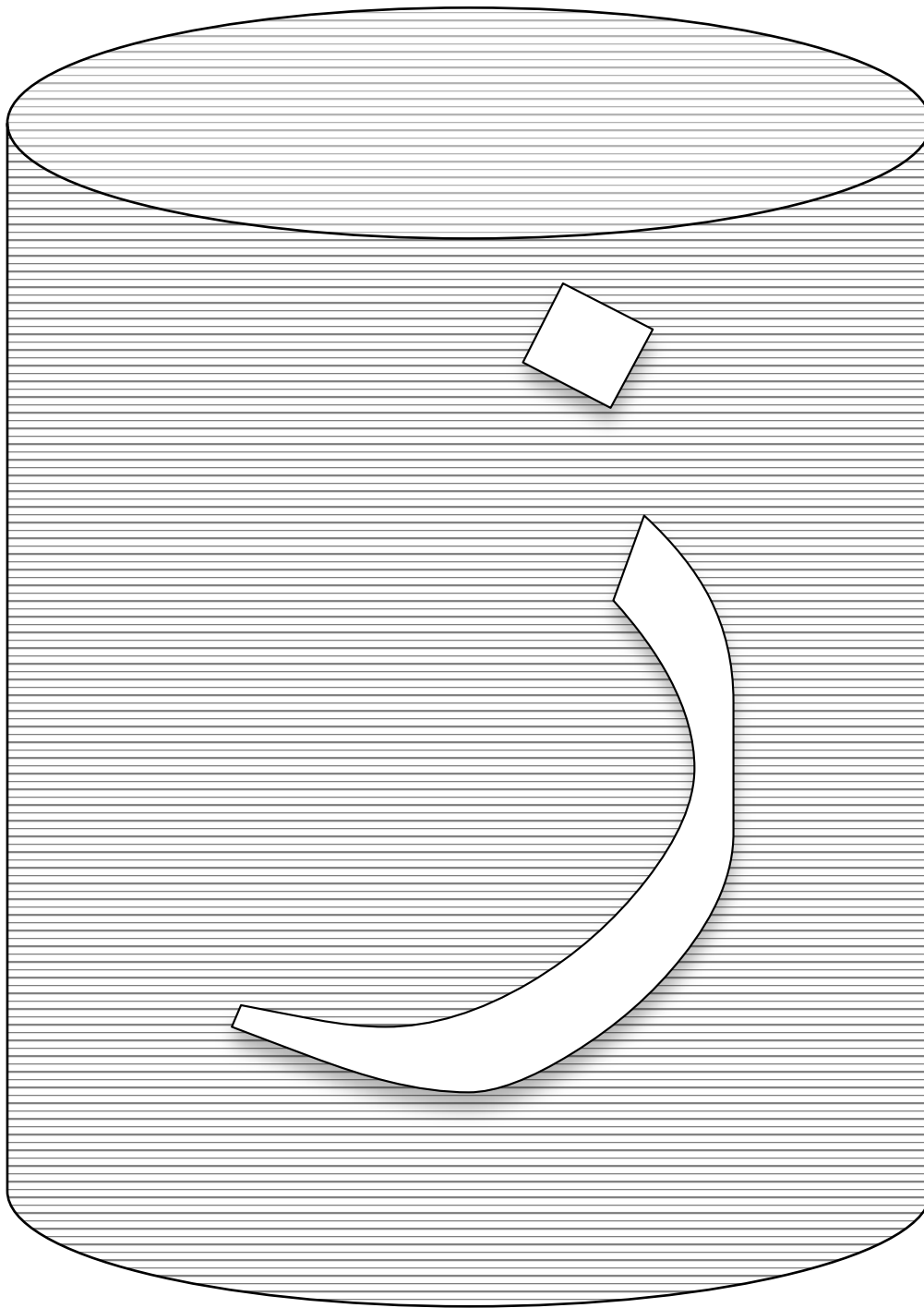

ZE

(za)

EXERCISE 20: LETTER RECOGNITION

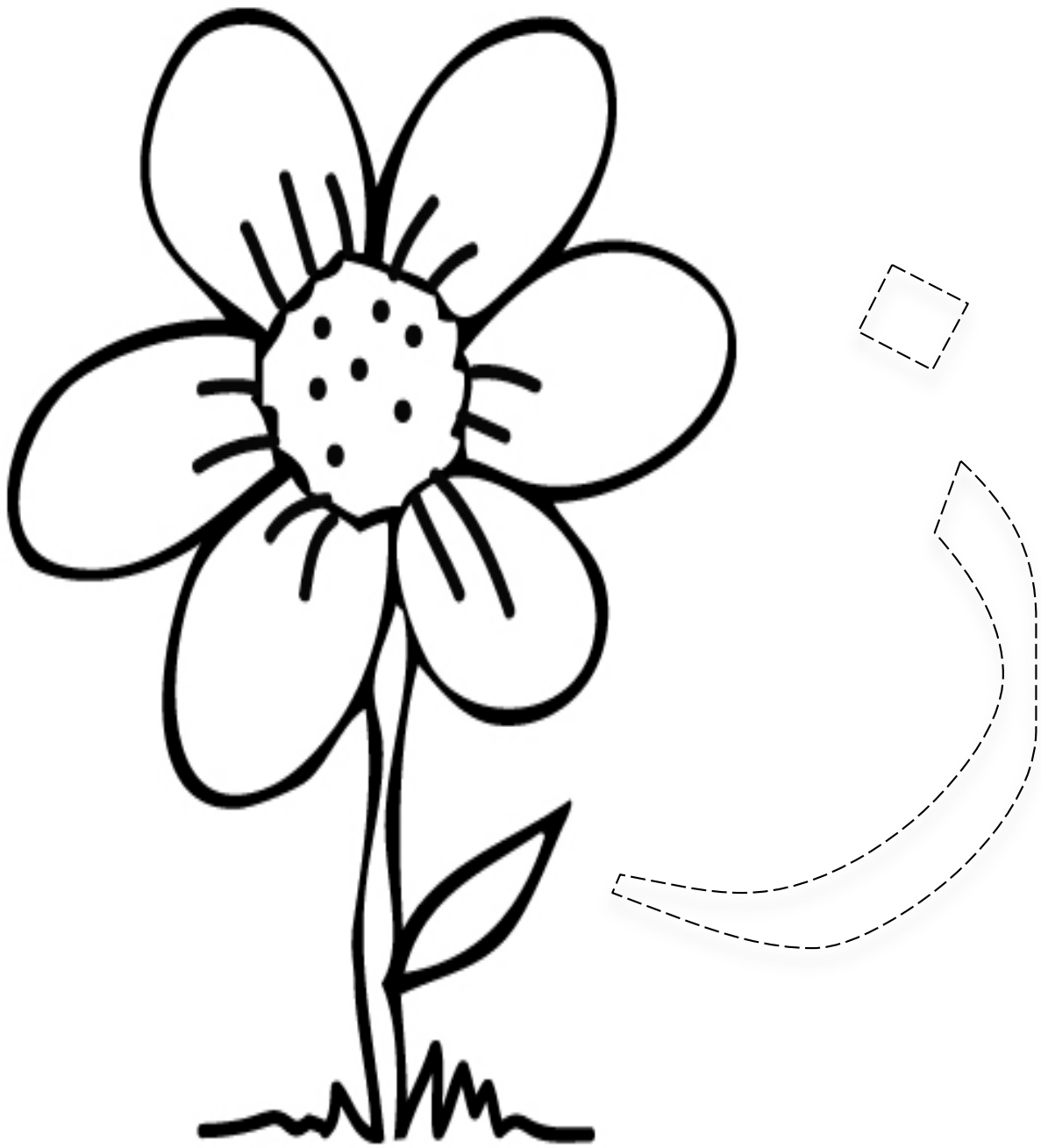

ZE زِهْ زَهْرَ (za)





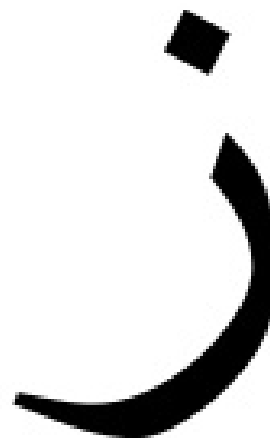
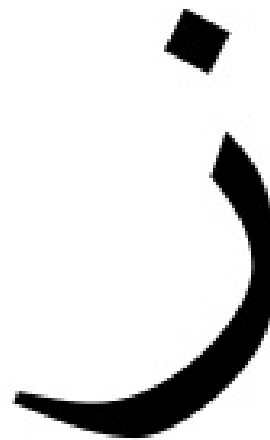
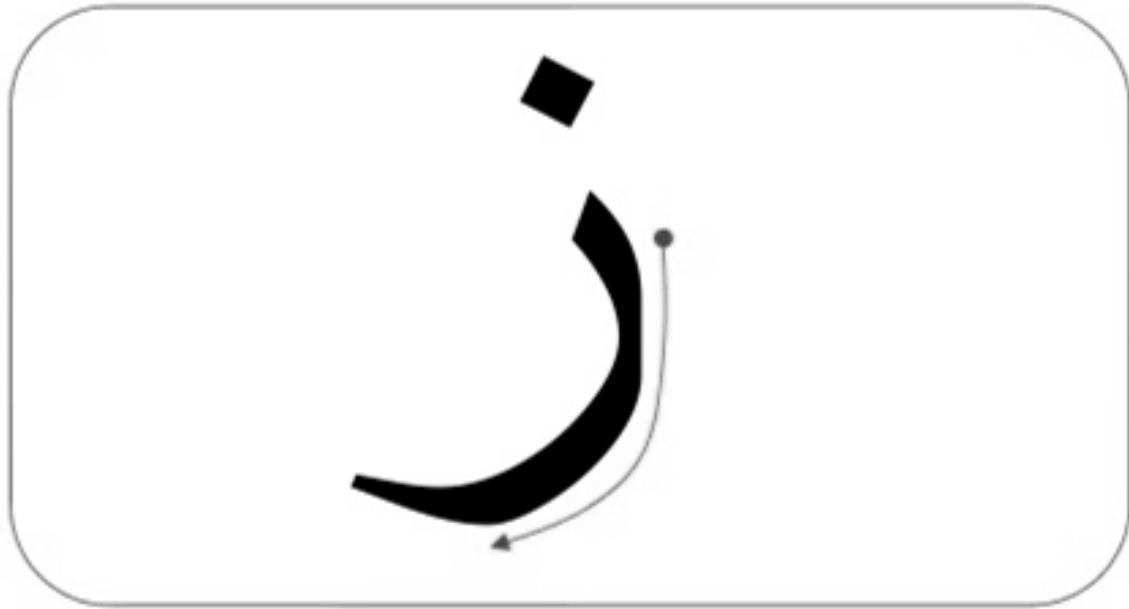

# EXERCISE 21: LETTER RECOGNITION

Join the dots and write the letter

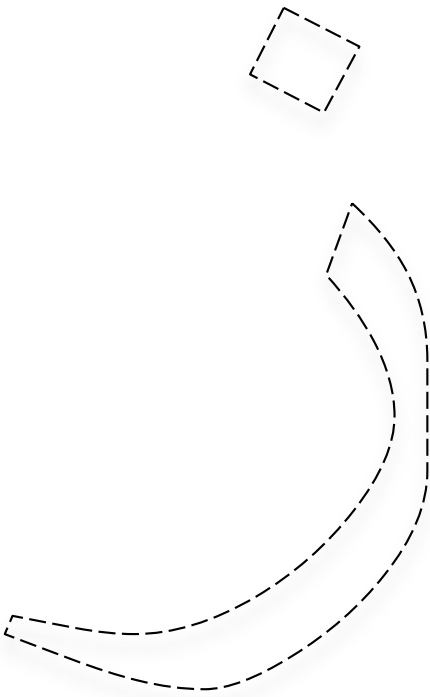

**EXERCISE 22: LETTER RECOGNITION**

**Choose the matching letter below**

		
		

EXERCISE 23: LETTER RECOGNITION

SIN (sa)

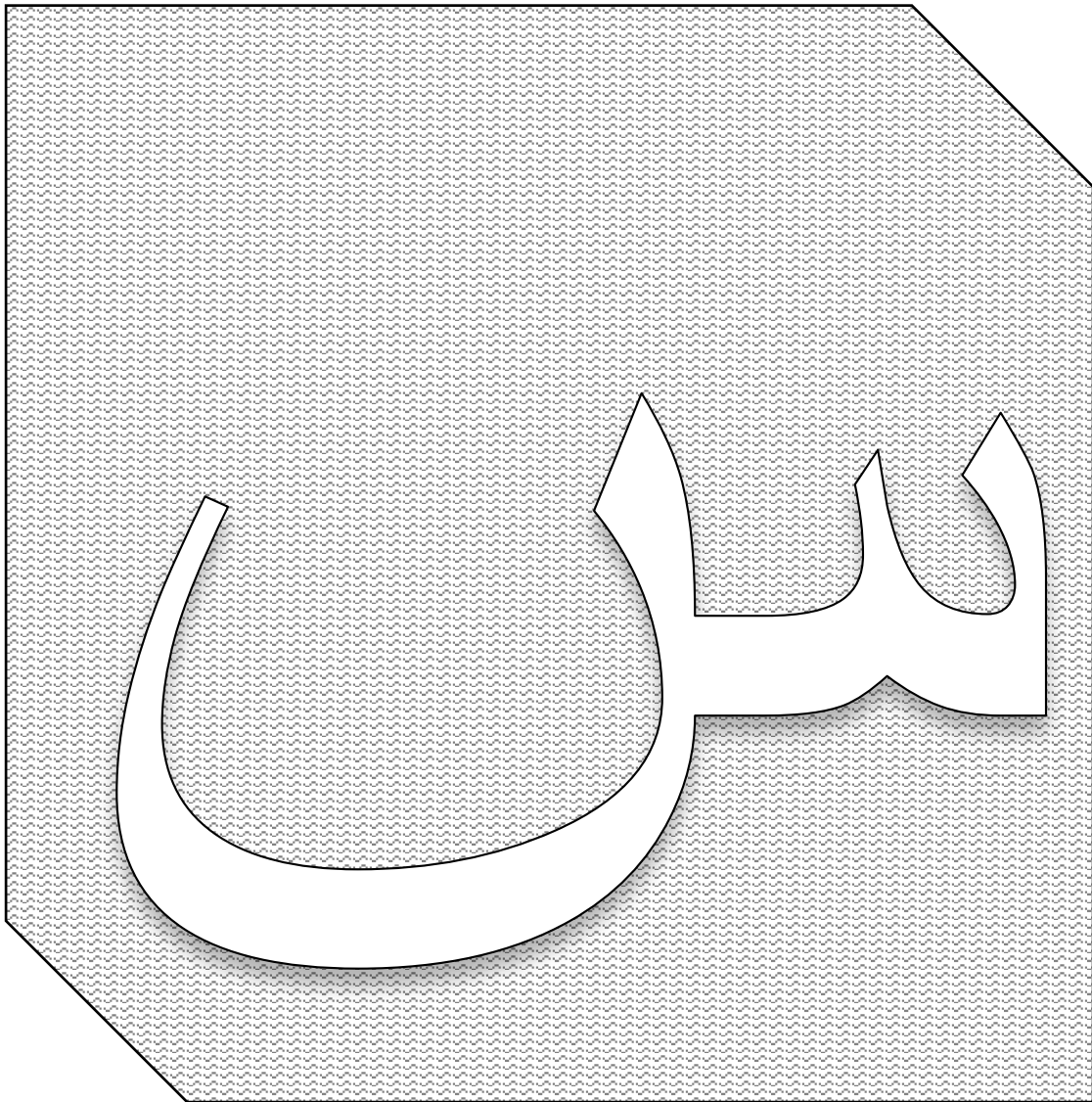

EXERCISE 24: LETTER RECOGNITION

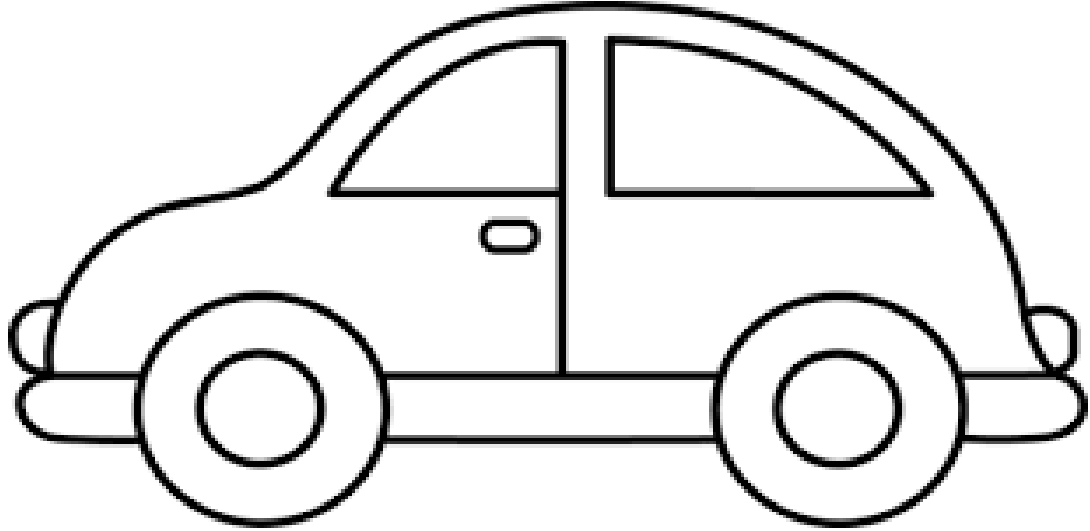

SIN سَيَّارَةٌ (sa)

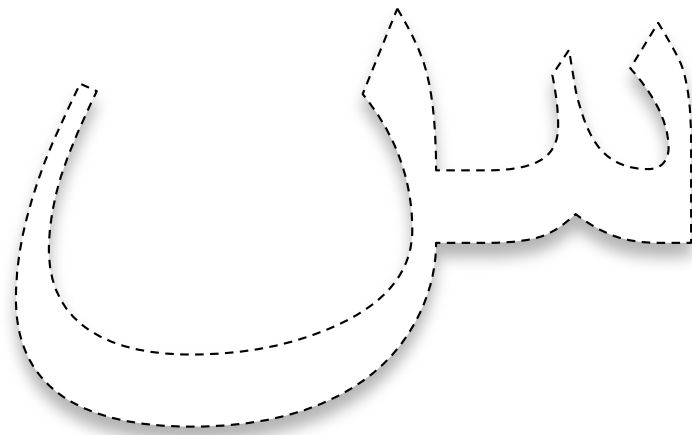

## EXERCISE 25: LETTER RECOGNITION

Join the dots and write the letter

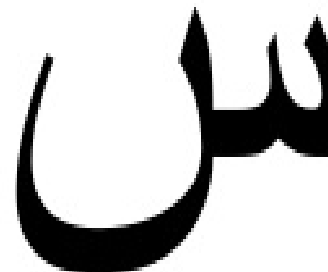
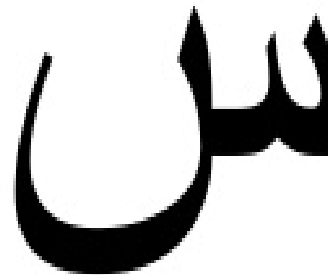
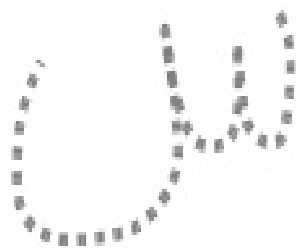
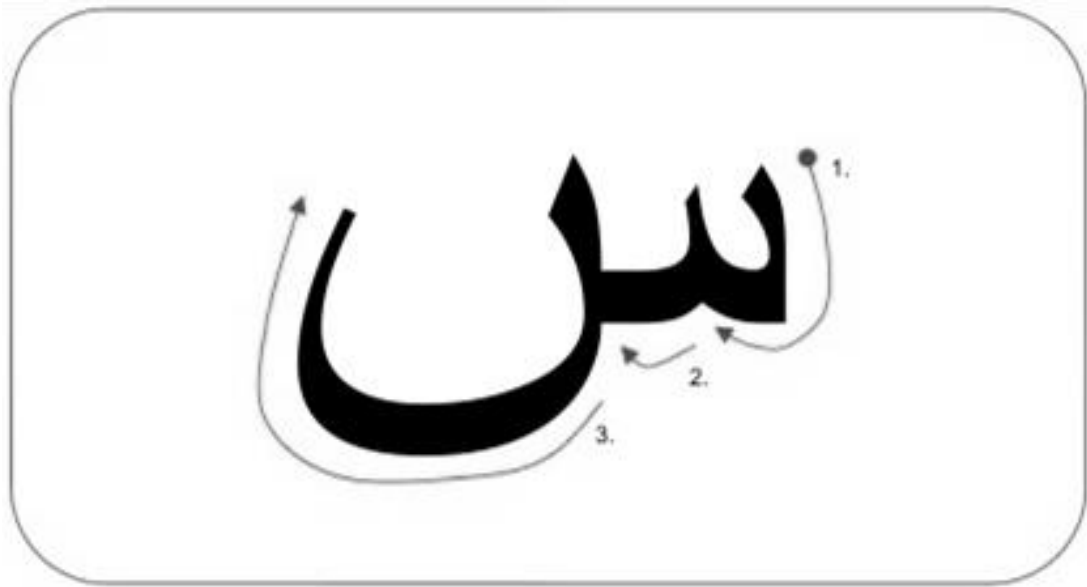

EXERCISE 26: LETTER RECOGNITIONChoose the matching letter below

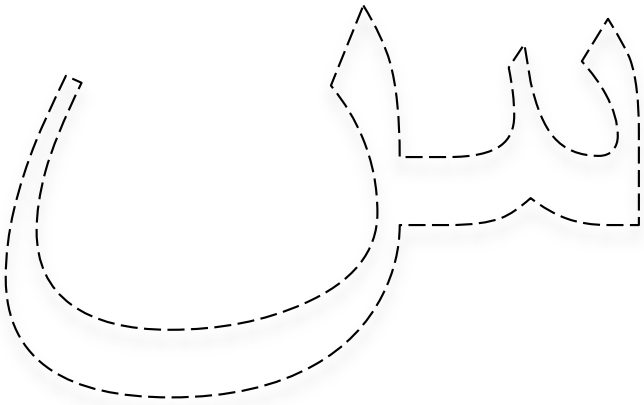
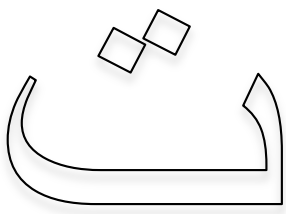
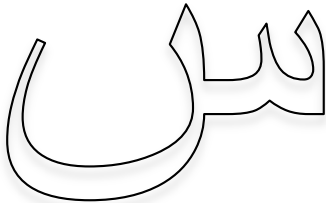
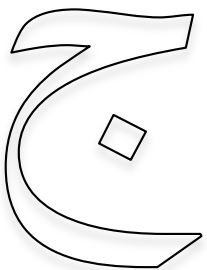
EXERCISE 27: LETTER RECOGNITION

Shin (sh)

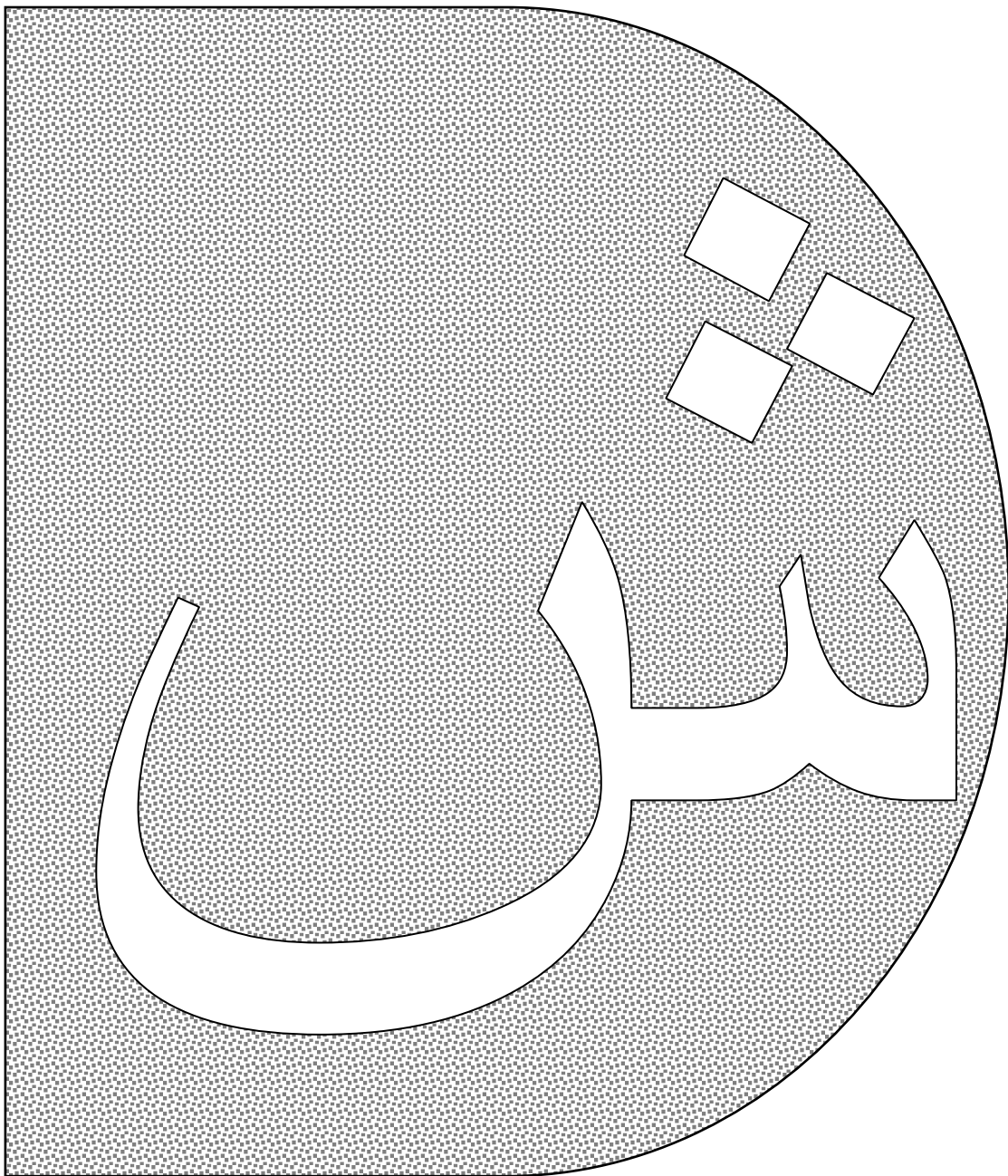

EXERCISE 28: LETTER RECOGNITION

Shin شَجَرَة (sh)

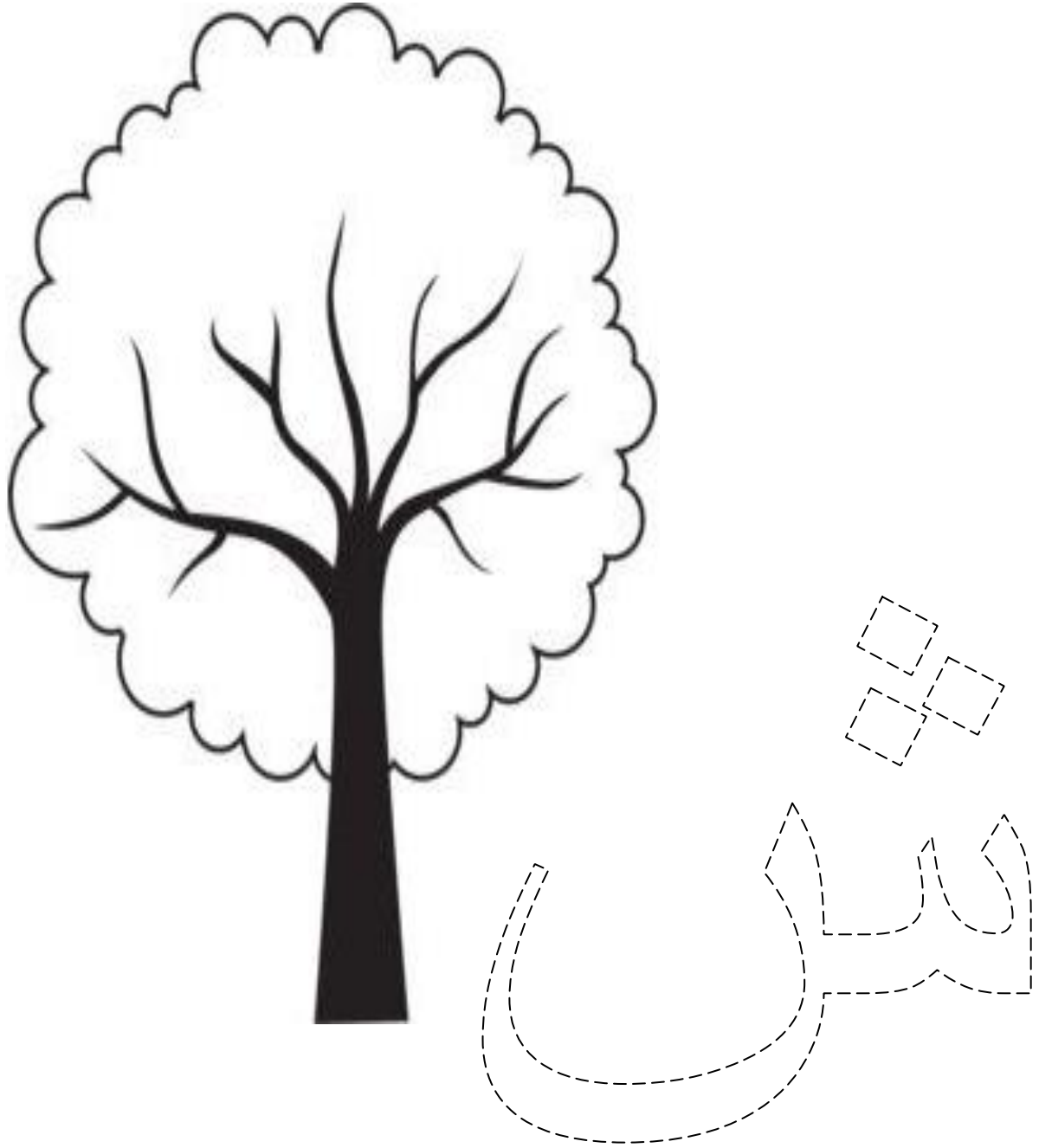



EXERCISE 29: LETTER RECOGNITION

Join the dots and write the letter

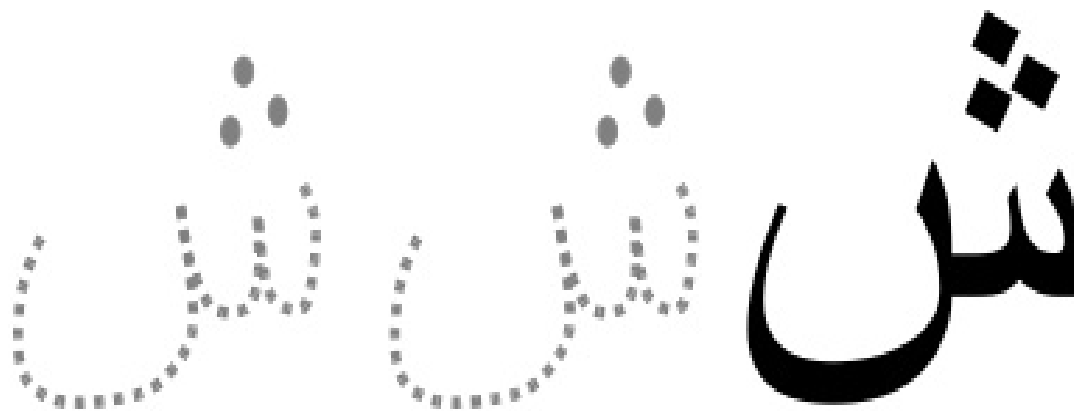
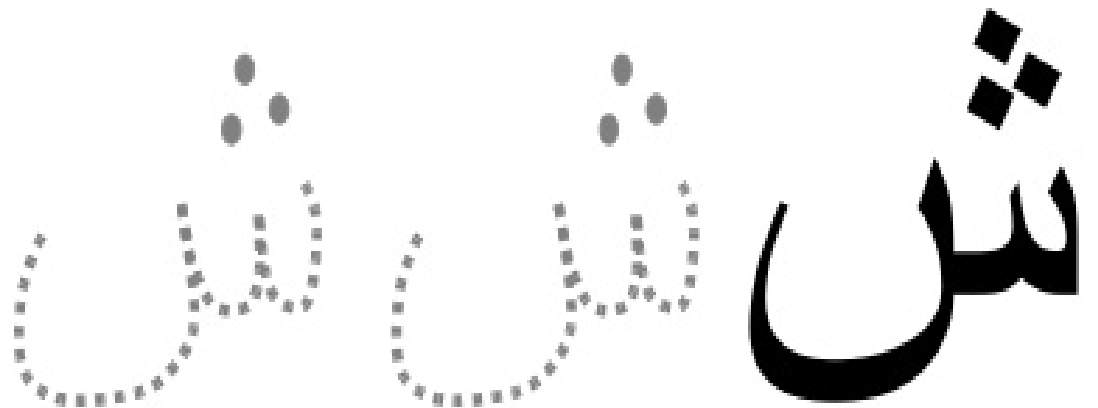
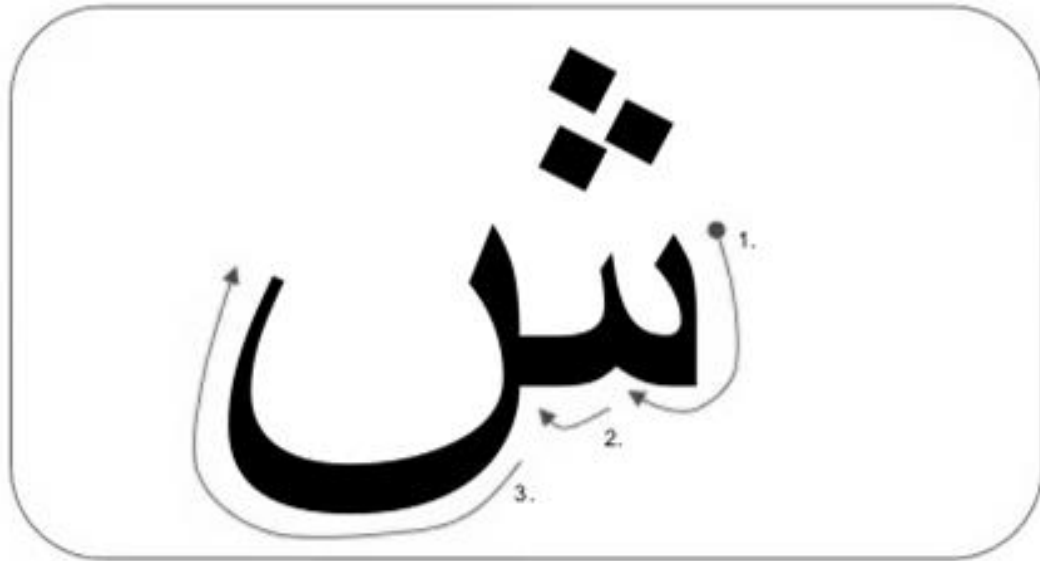

# EXERCISE 30: LETTER RECOGNITION

Choose the matching letter below

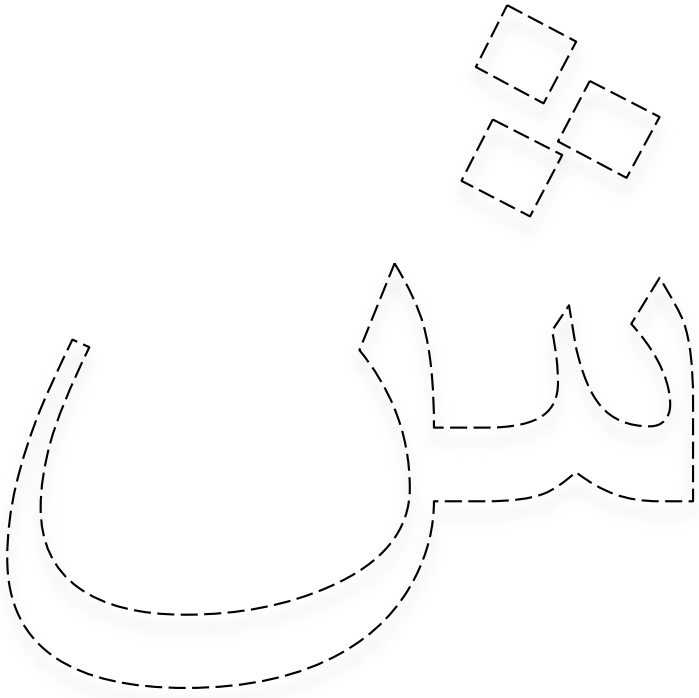
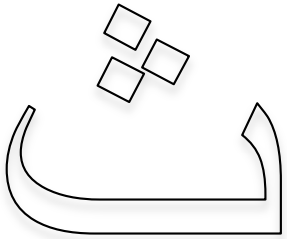
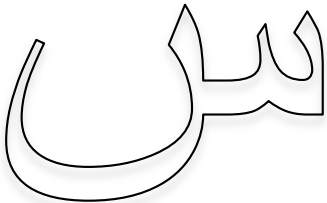
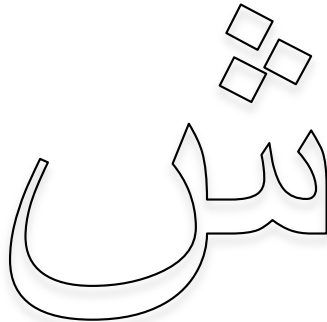

EXERCISE 31: MATCHING EXERCISERECOGNISING LETTERS ر TO ش (RE - SHIN)

Join the kettle to the tea cups with the matching letters.



EXERCISE 32: READING EXERCISERECOGNISING LETTERS ر TO ش (RE - SHIN)

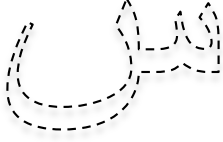

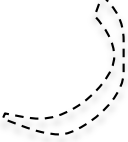
Read and identify the alphabets

ش	س	ز	ر
Shin (sh)	Sin (sa)	Ze (za)	Re (ra)
			

EXERCISE 33: READING EXERCISE

ش	ر	ز	ش
ز	ش	ر	س
ش	س	ز	ر

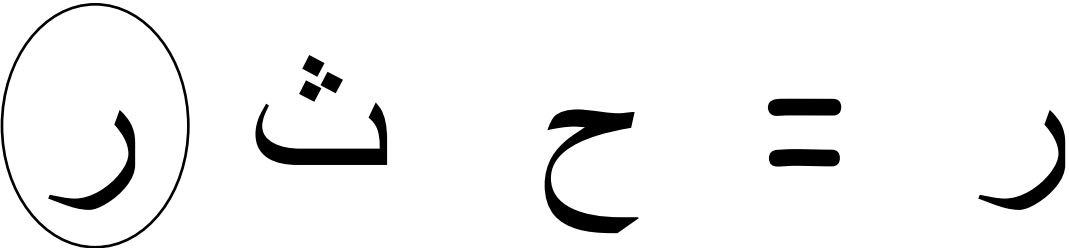
EXERCISE 34: LETTER RECOGNITIONCircle the correct matching letter as shown

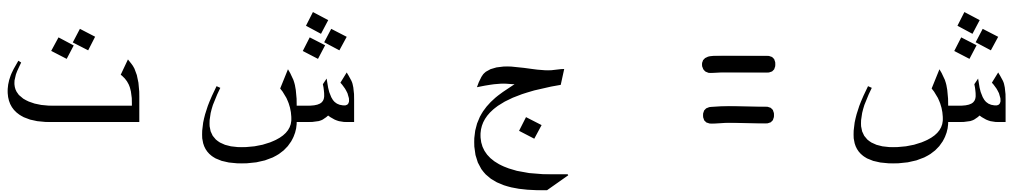



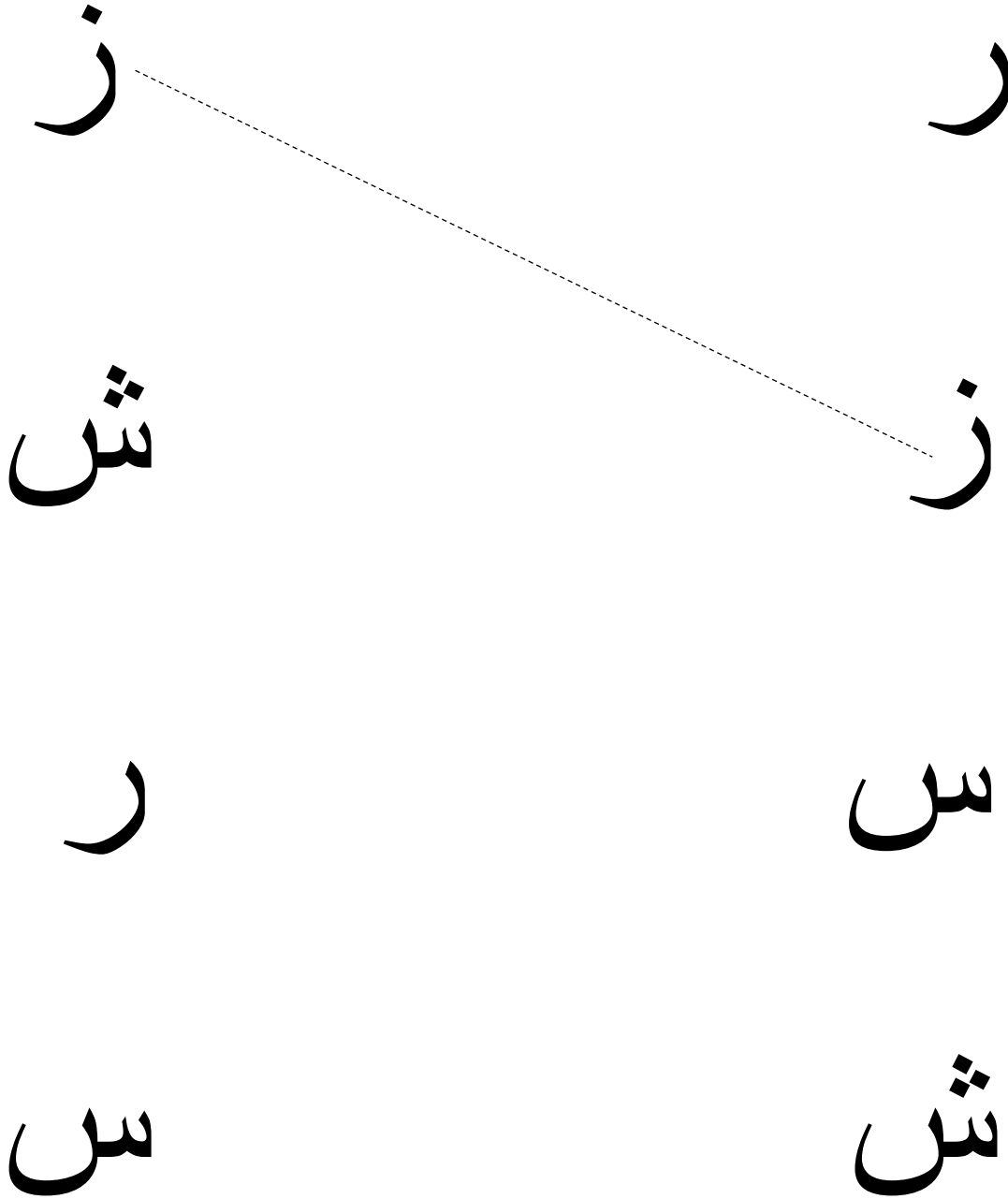

EXERCISE 35: JOIN THE MATCHING LETTERS



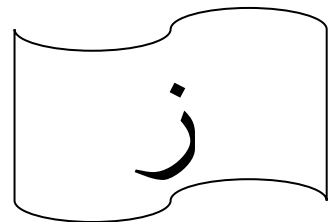
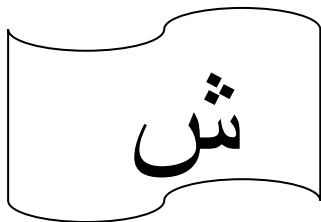
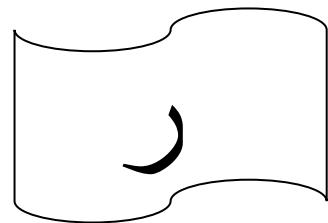
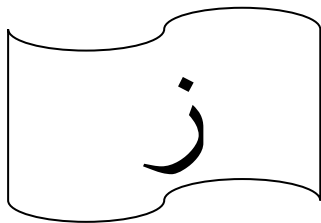
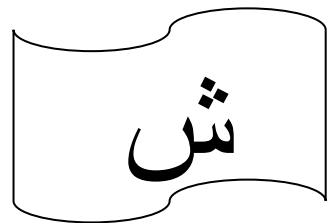
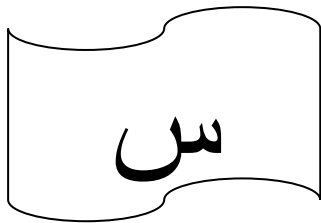
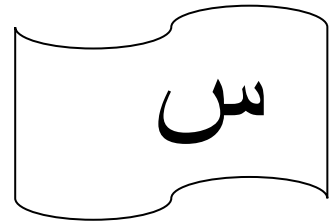
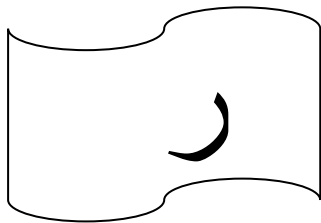









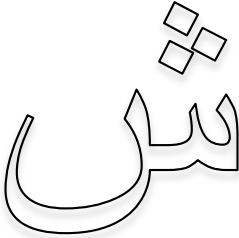

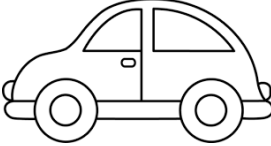
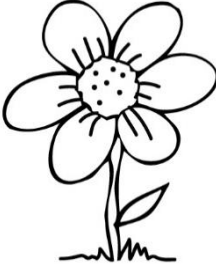

EXERCISE 36: JOINING EXERCISERECOGNISING LETTERS ر TO ش (RE - SHIN)

Join the banners with the matching letters



**EXERCISE 37: WRITING EXERCISE**

Join the dots and write the letter

<p>SHIN (sh)</p>	<p>SIN (sa)</p>	<p>ZE (za)</p>	<p>RE (ra)</p>
			
			
			
			



EXERCISE 38: LETTER RECOGNITION

SAAD (ssa)

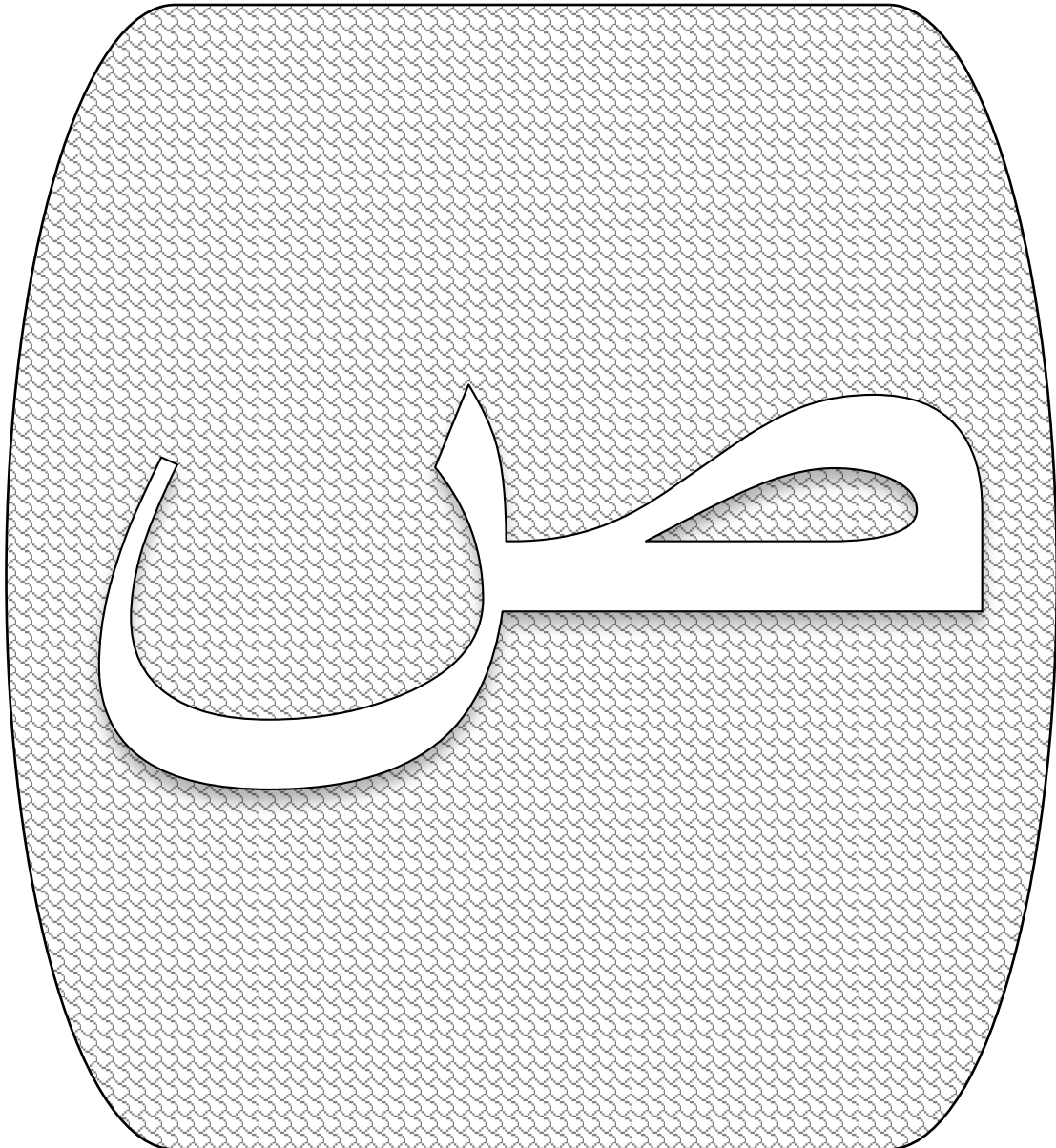

EXERCISE 39: LETTER RECOGNITION

Saad صُ و فُ (ssa)

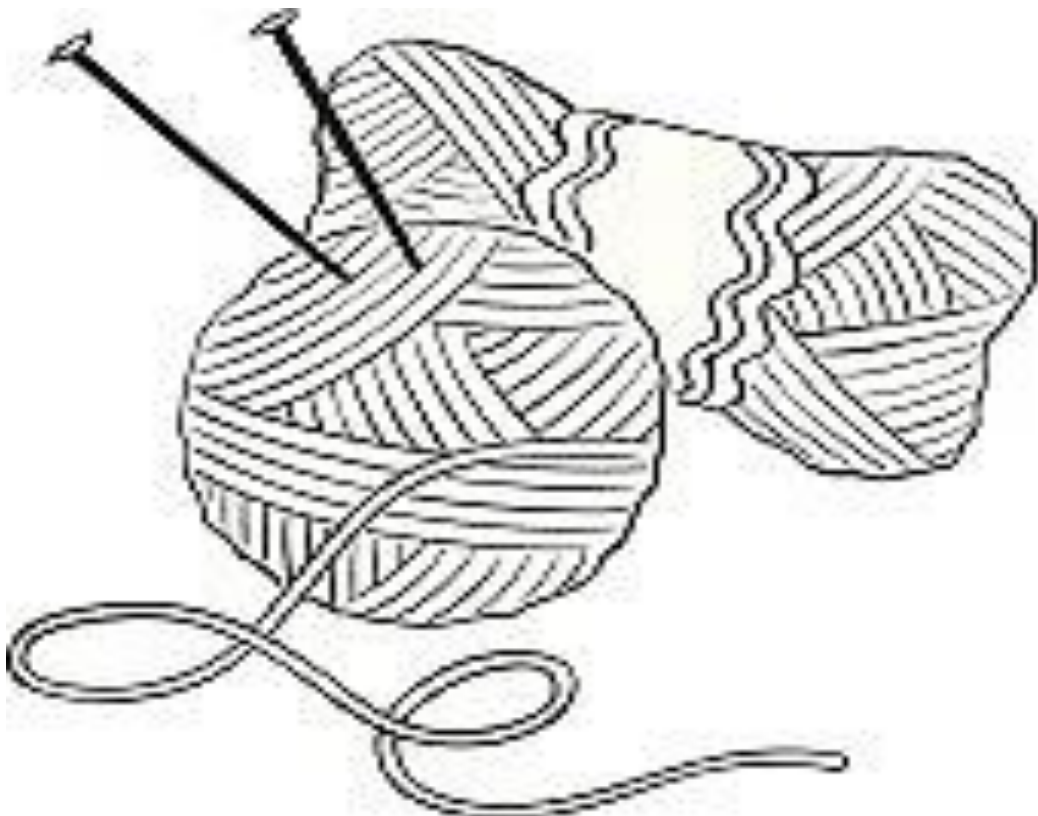
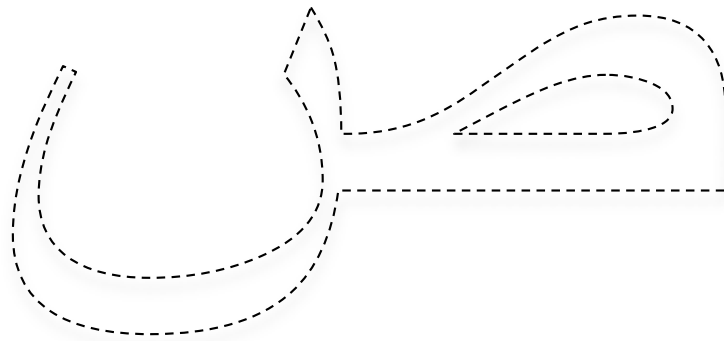

## EXERCISE 40: LETTER RECOGNITION

Join the dots and write the letter

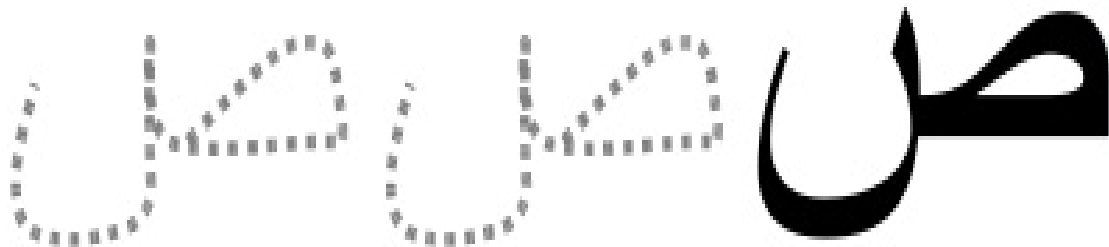
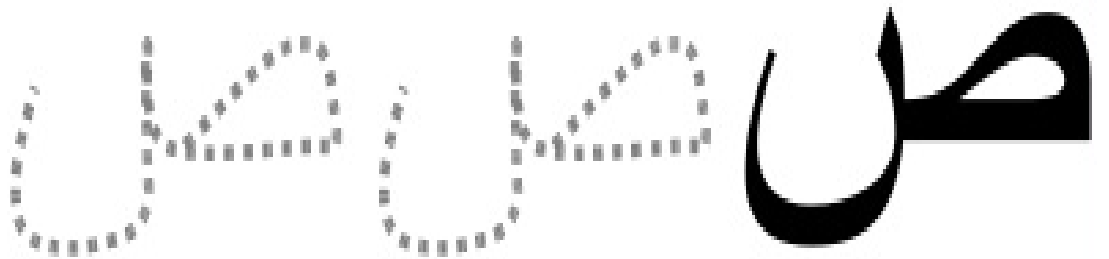
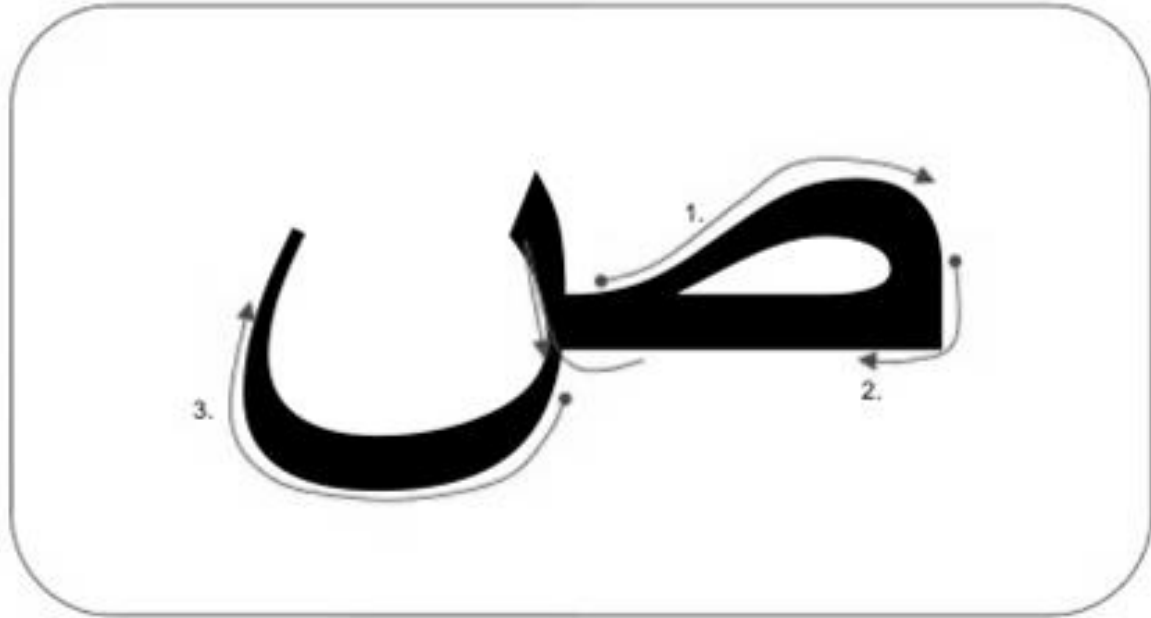

# EXERCISE 41: LETTER RECOGNITION

Choose the matching letter below

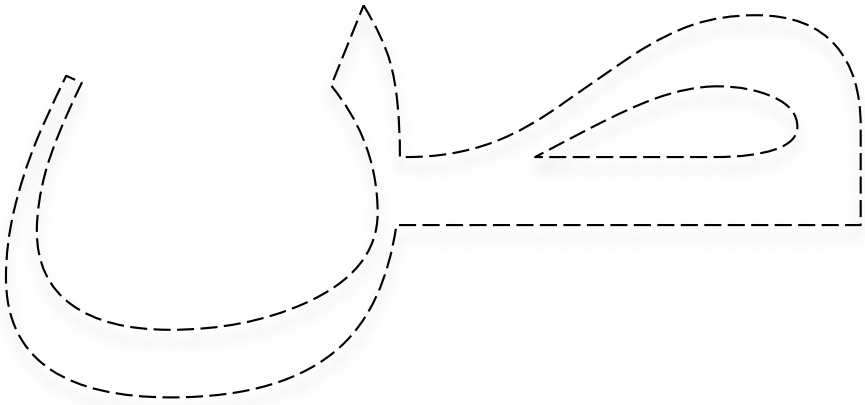
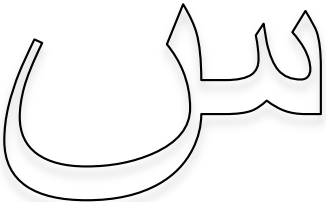
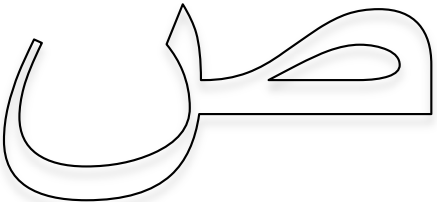
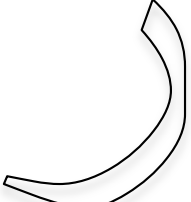
EXERCISE 42: LETTER RECOGNITION

DHAAD (dha)

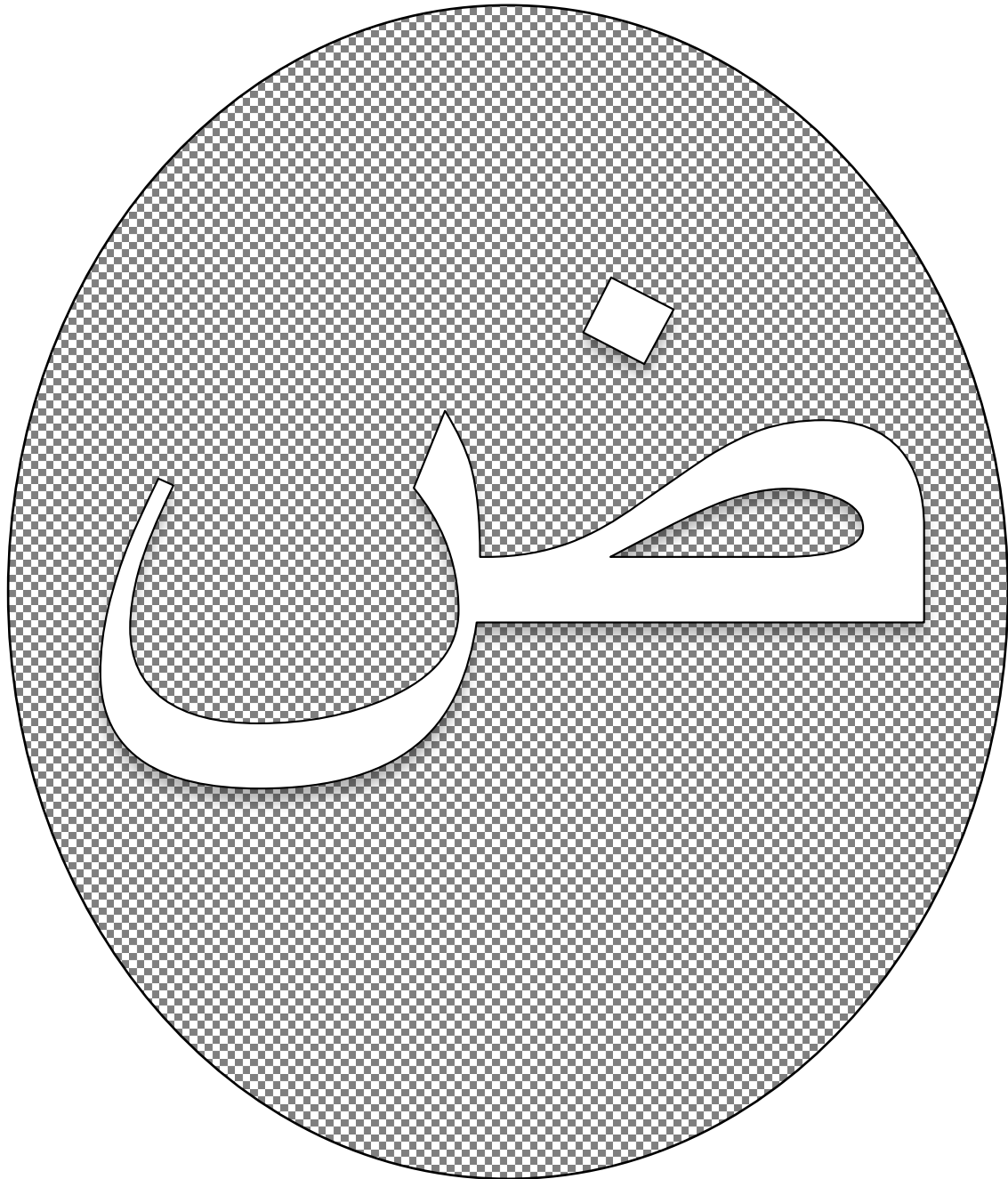

EXERCISE 43: LETTER RECOGNITION

Dhaad

ذ ڤا ڤا

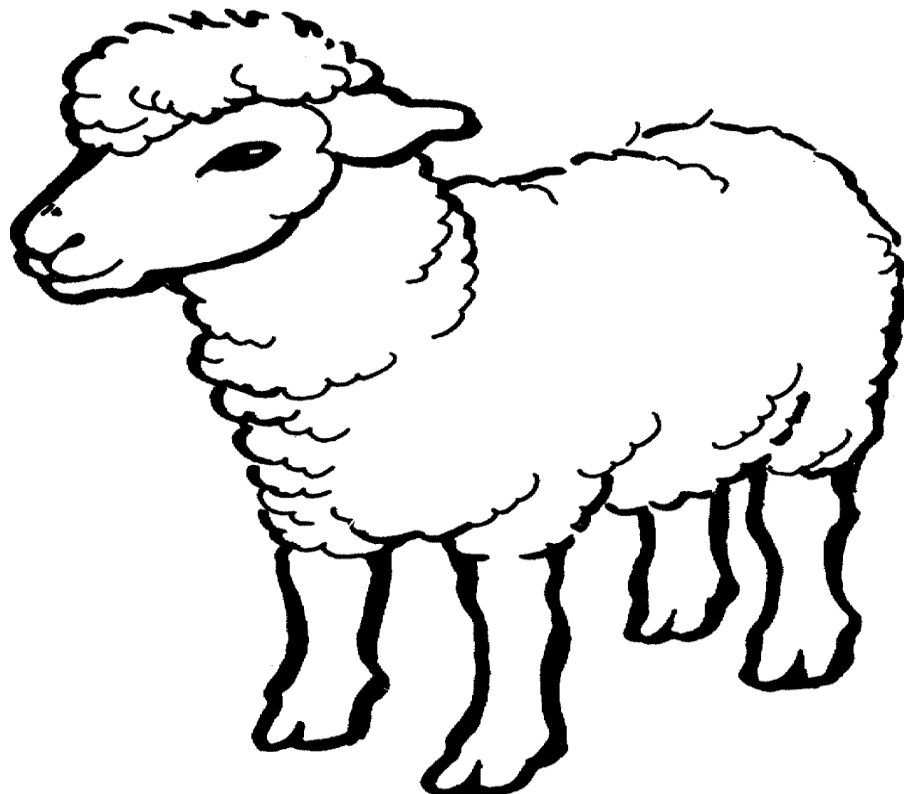
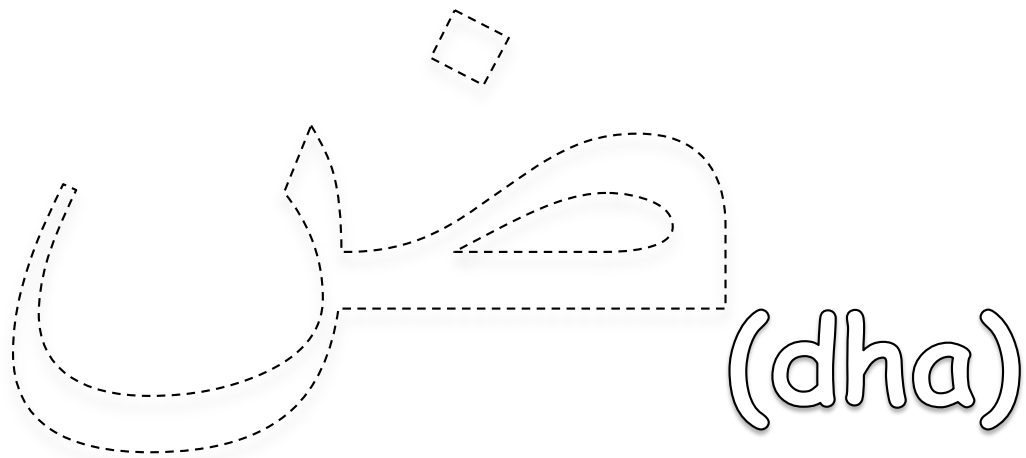

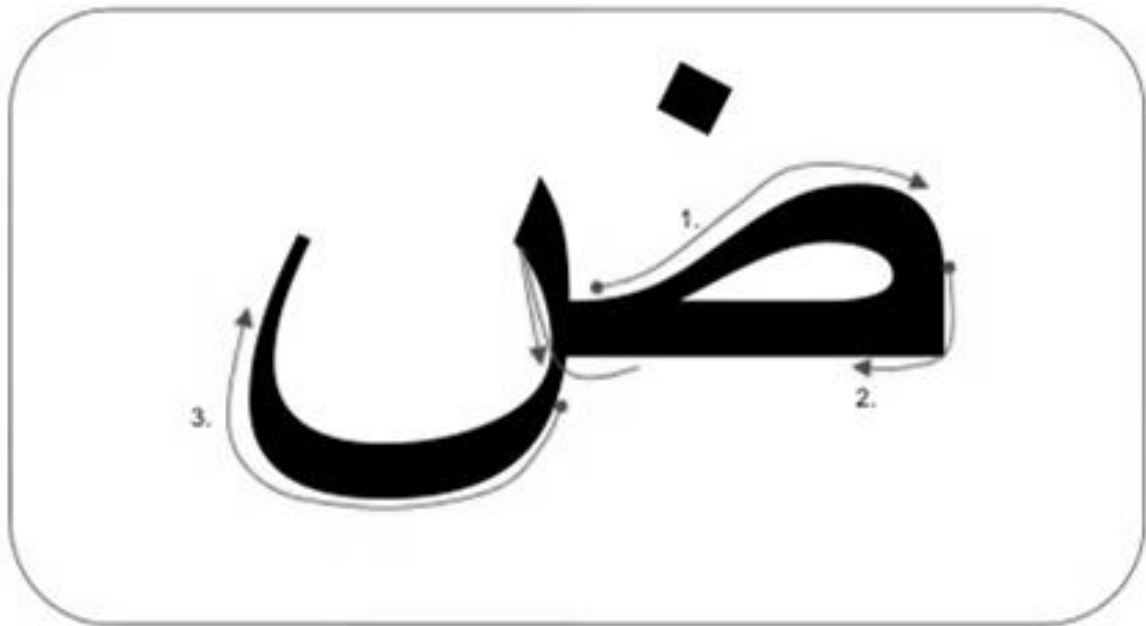

# EXERCISE 44: LETTER RECOGNITION

Join the dots and write the letter

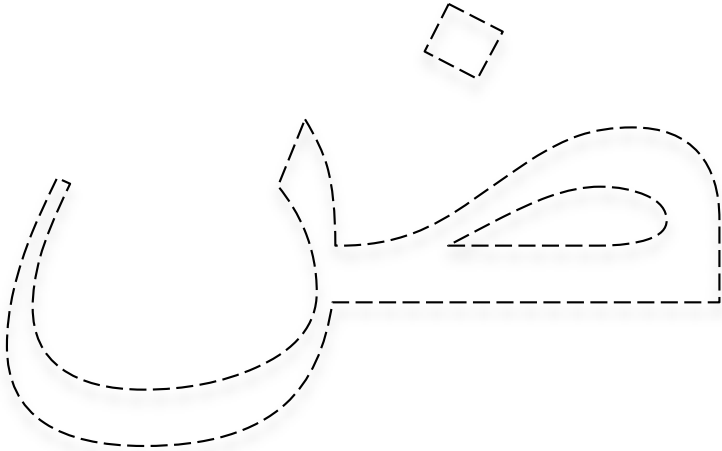

**EXERCISE 45: LETTER RECOGNITION**

Choose the matching letter below

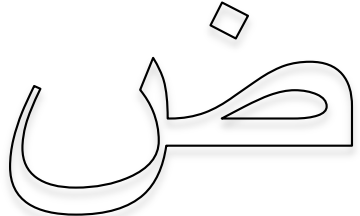

EXERCISE 46: LETTER RECOGNITION

TTA (tta)

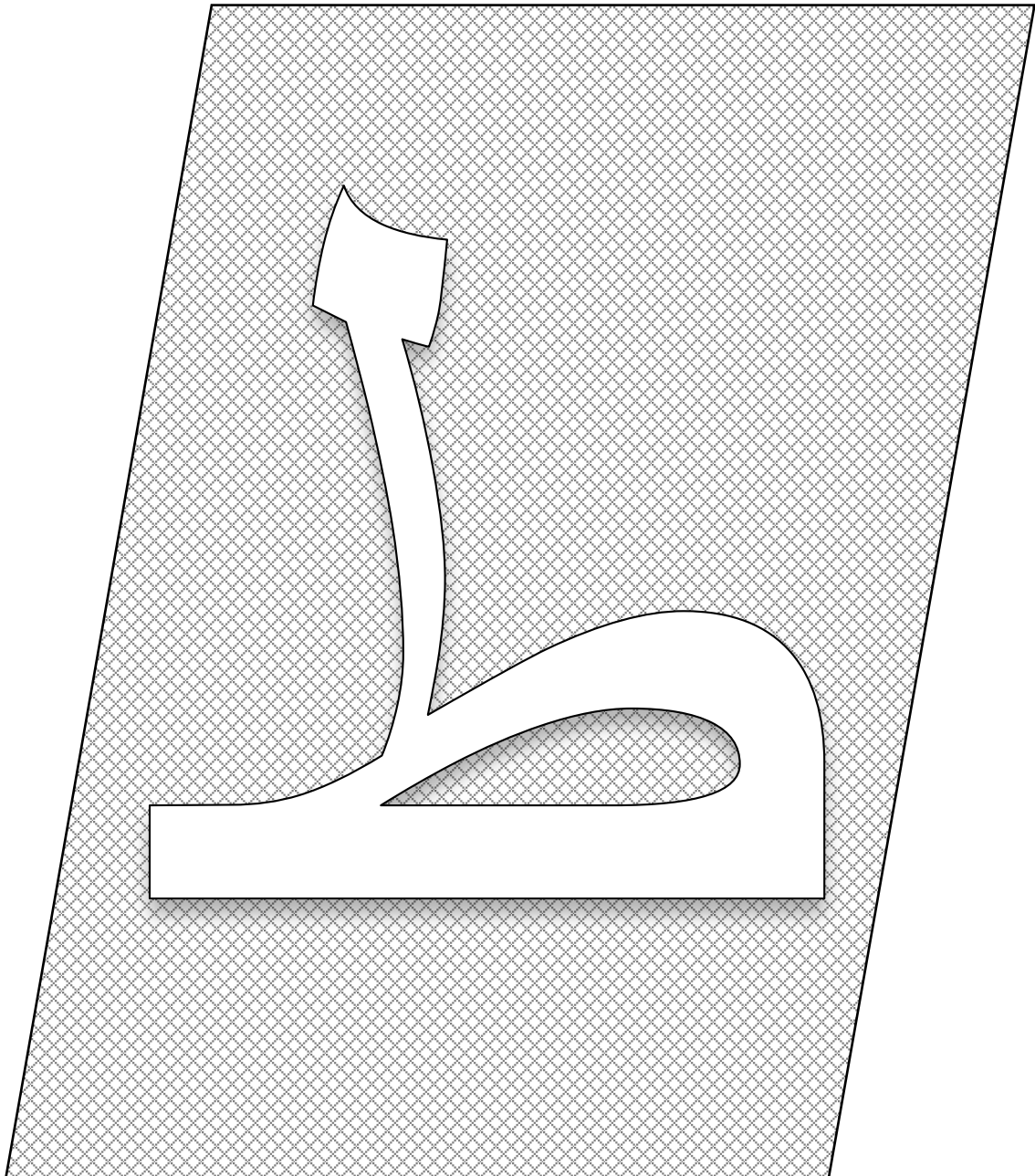

EXERCISE 47: LETTER RECOGNITION

Tta طَاءِ رُ (tta)

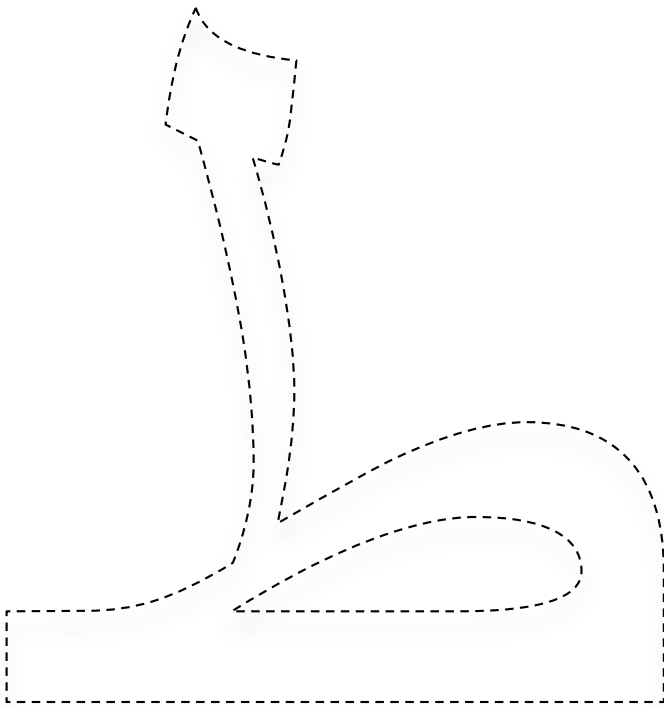
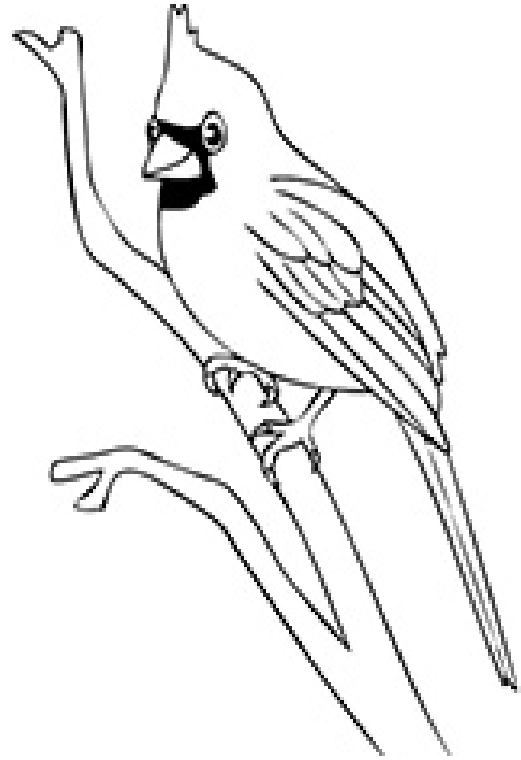

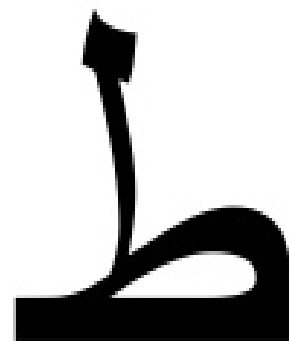
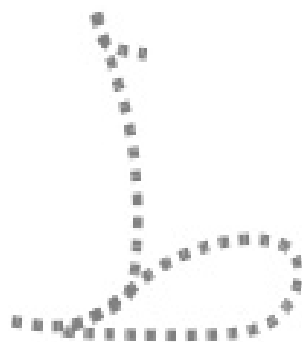
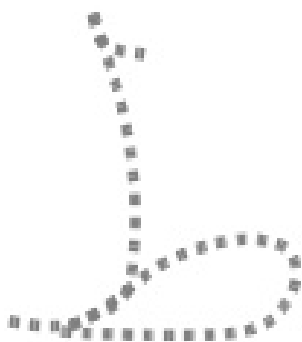
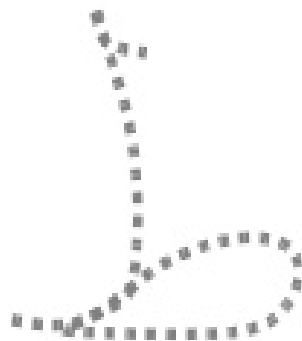
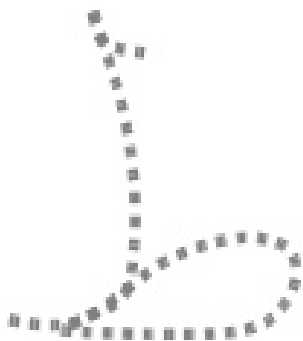
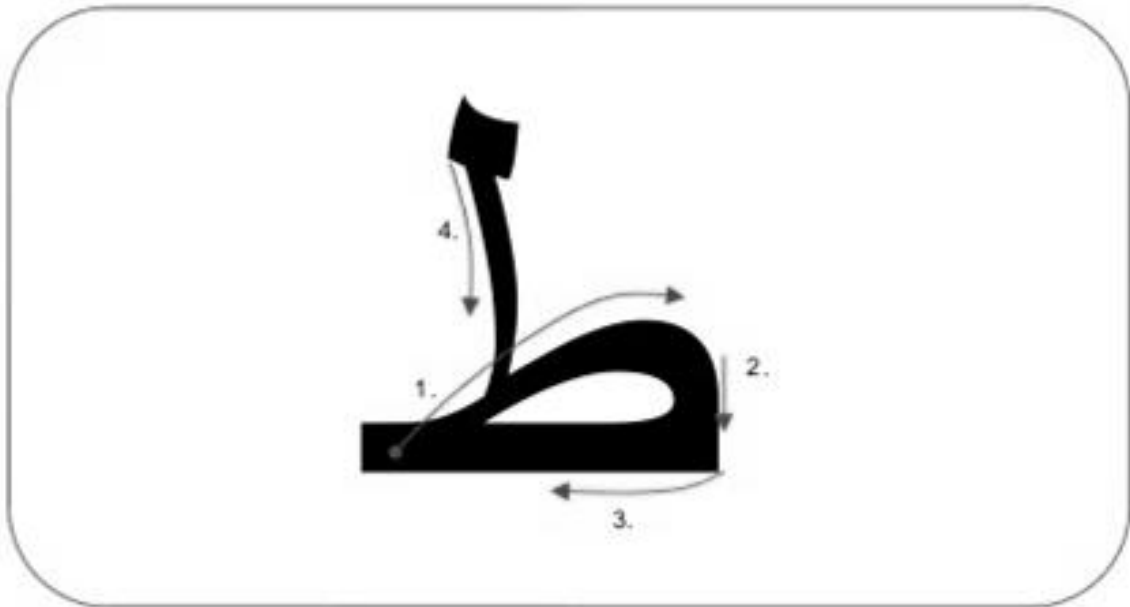

# EXERCISE 48: LETTER RECOGNITION

Join the dots and write the letter

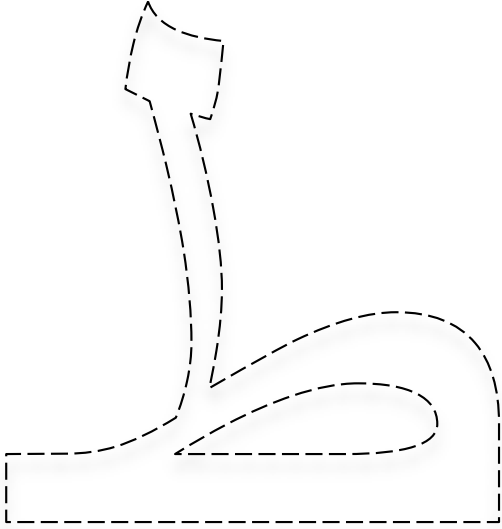
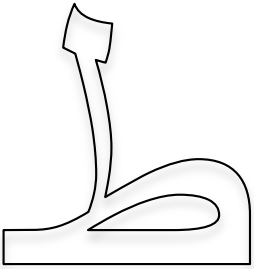
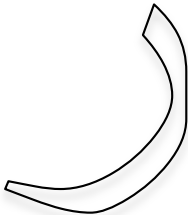

# EXERCISE 49: LETTER RECOGNITION

Choose the matching letter below

EXERCISE 50: LETTER RECOGNITION

ZHE (zha)

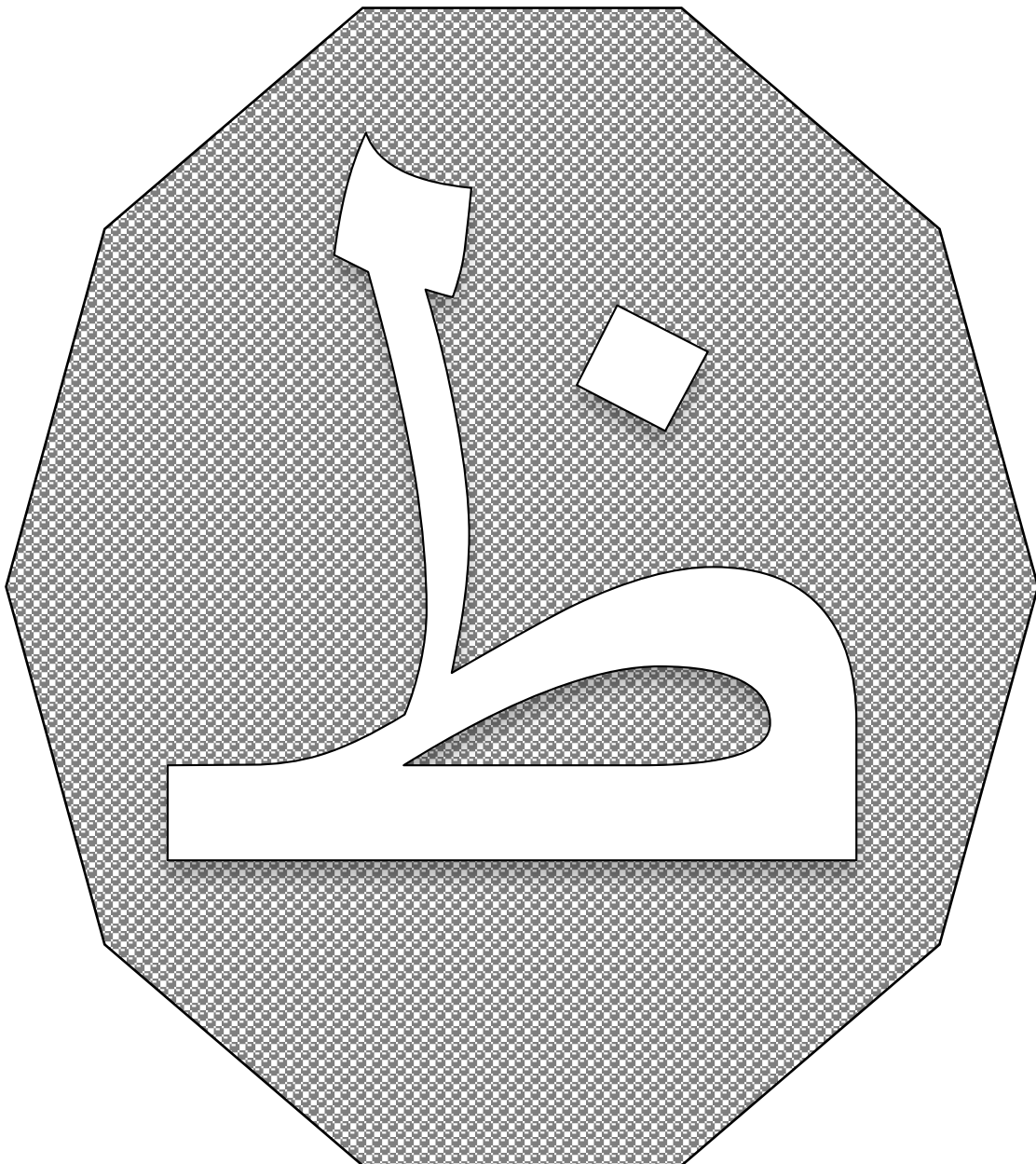

EXERCISE 51: LETTER RECOGNITION

Zhe ظ ر ف (zha)

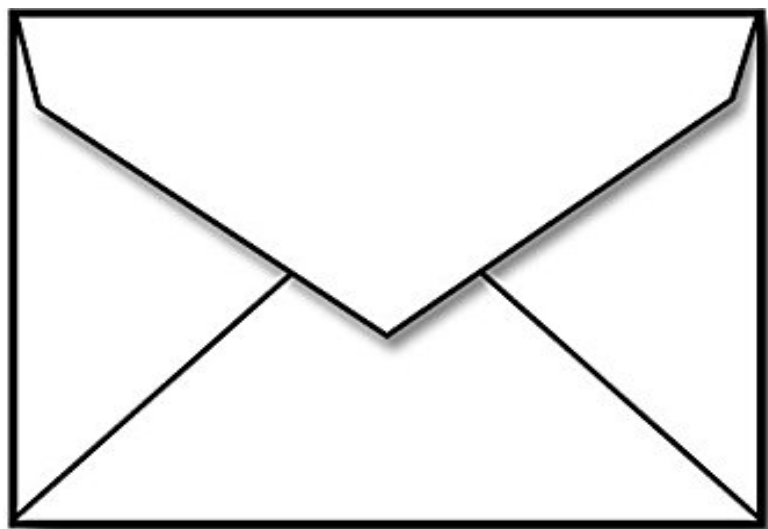
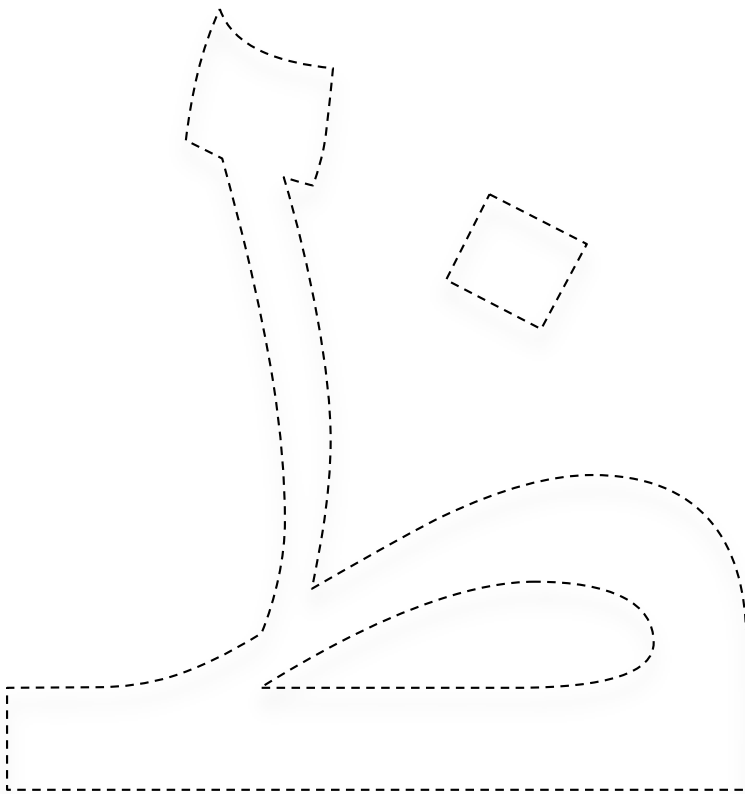

## EXERCISE 52: LETTER RECOGNITION

Join the dots and write the letter

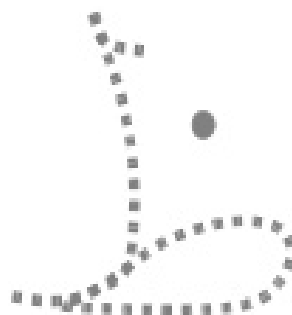
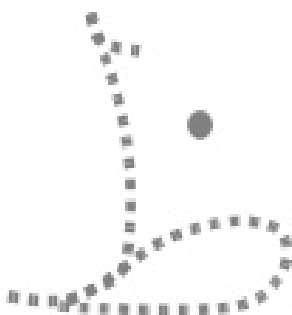
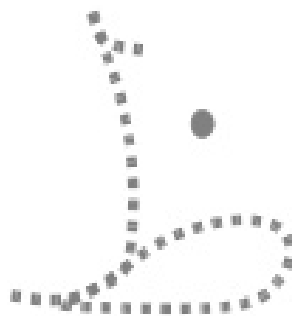
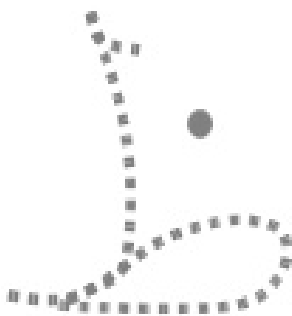
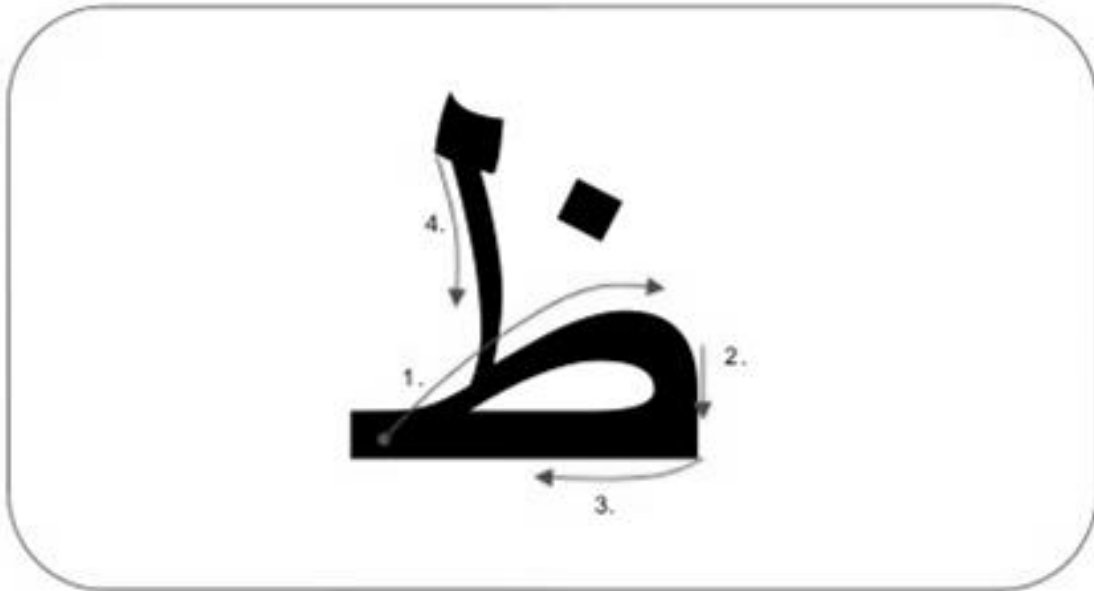



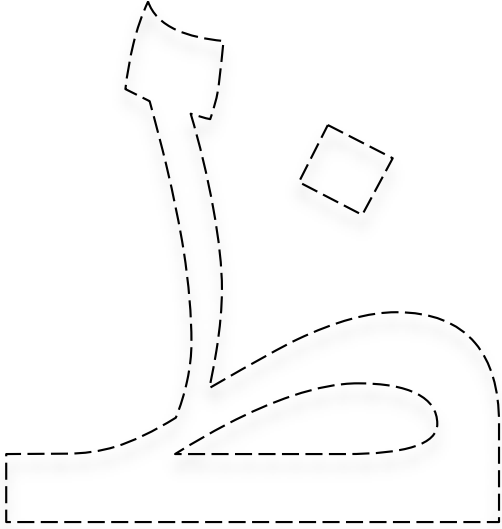
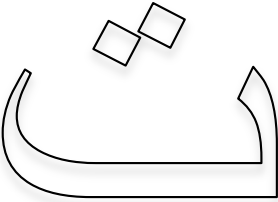
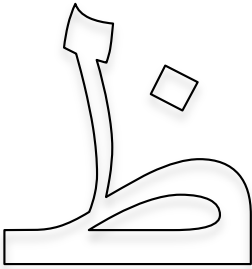
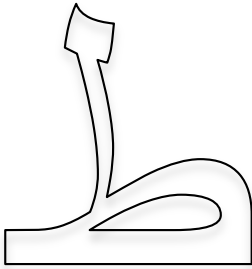

# EXERCISE 53: LETTER RECOGNITION

Choose the matching letter below







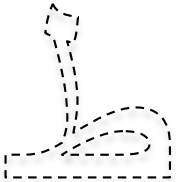
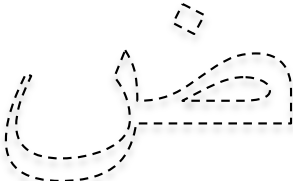
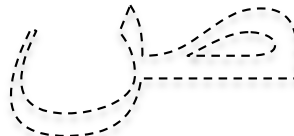



		
		



EXERCISE 54: READING EXERCISERECOGNISING LETTERS ظ TO ص (SAAD - ZHE)

Read and identify the alphabets			
			
Zhe (zha)	Tta (tta)	Dhaad (dha)	Saad (ssa)
			

EXERCISE 55: READING EXERCISE

EXERCISE 56: LETTER RECOGNITIONCircle the correct matching letter as shown

ث	ذ	ص	=	ص
ض	ر	س	=	ض
ث	ط	خ	=	ط
ظ	ب	ا	=	ظ

EXERCISE 57: JOIN THE MATCHING LETTERS

ظ

ص

ظ

ظ

ط

ظ

ص

ط

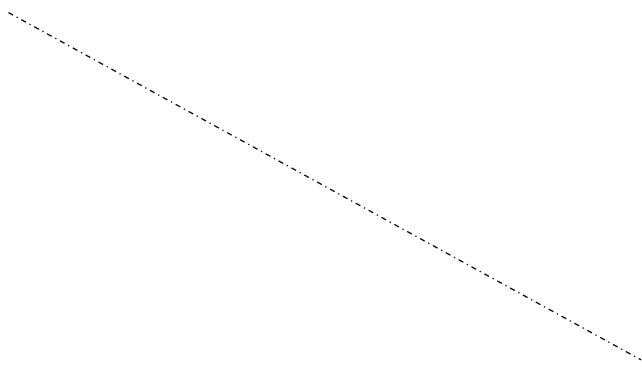







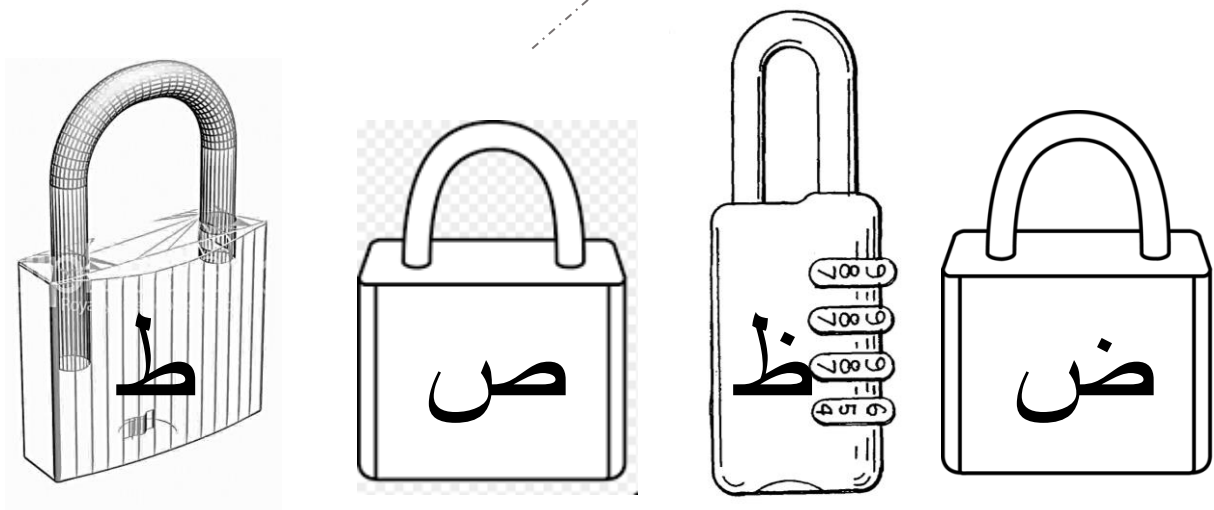
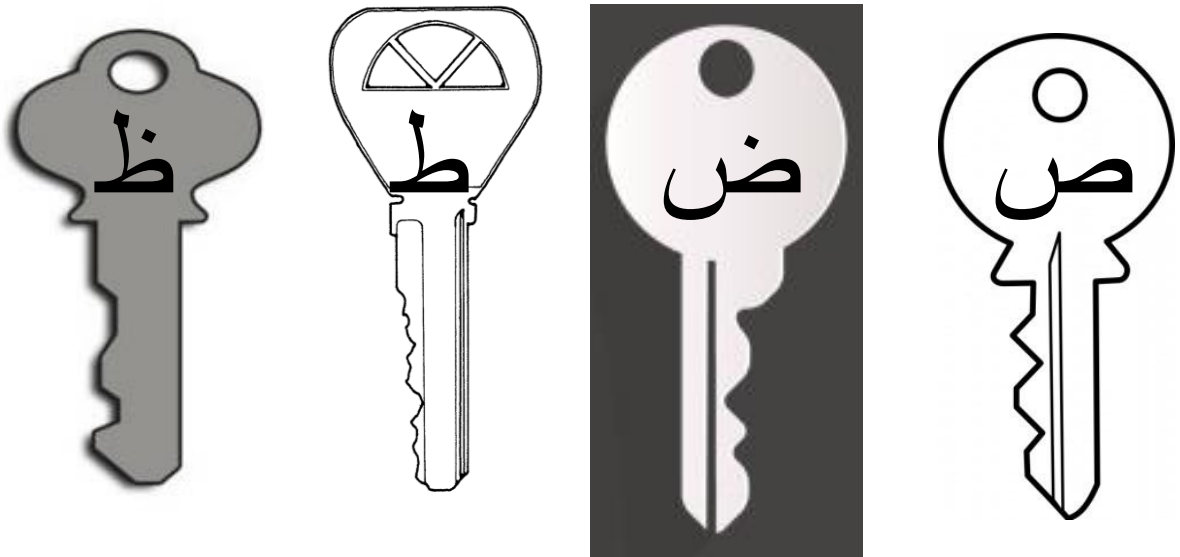

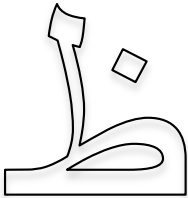
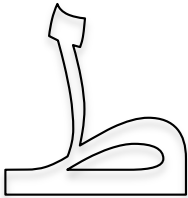
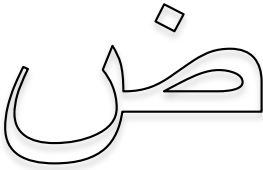

# EXERCISE 58: JOINING EXERCISE

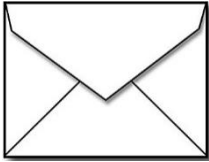
## RECOGNISING LETTERS ظ TO ص (SAAD - ZHE)

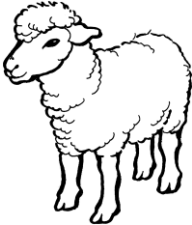
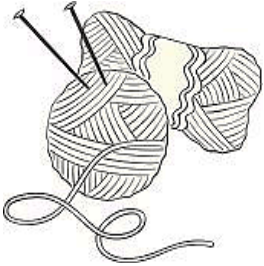
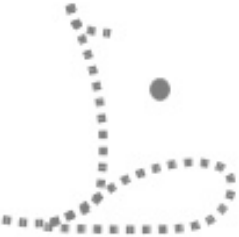
Join the keys with the locks that have a matching letter

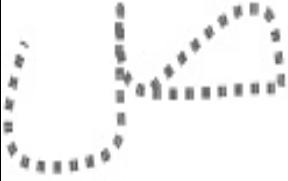

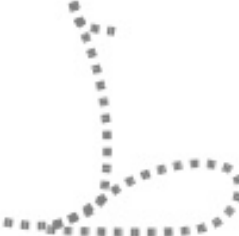
**EXERCISE 59: WRITING EXERCISE**Join the dots and write the letter

ZHE (zha)	TTA (tta)	DHAAD (dha)	SAAD (ssa)
			
			
			
			

EXERCISE 60: LETTER RECOGNITION

AYN (a-heavy)

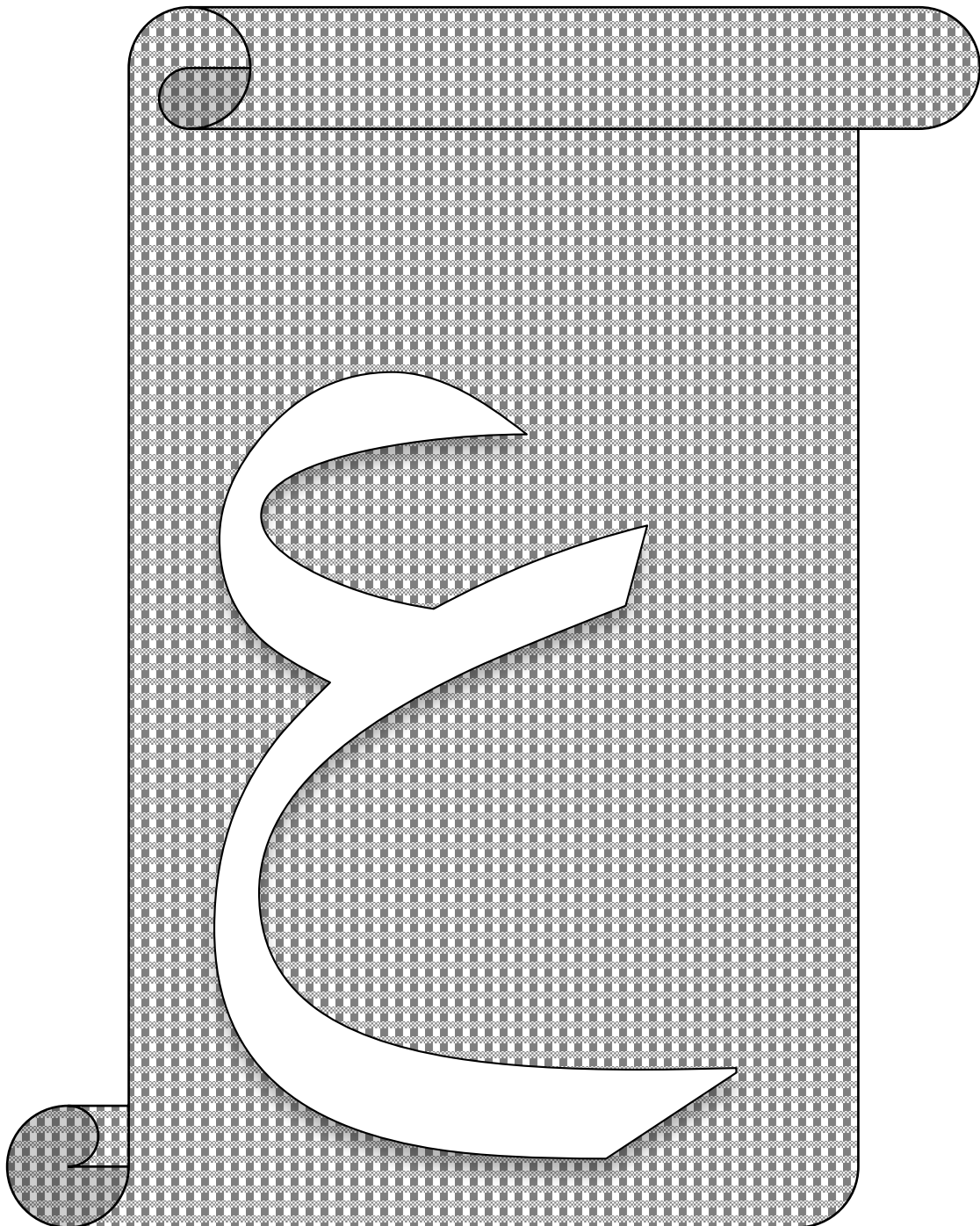

EXERCISE 61: LETTER RECOGNITION

Ayn

عَيْنُ

(a)

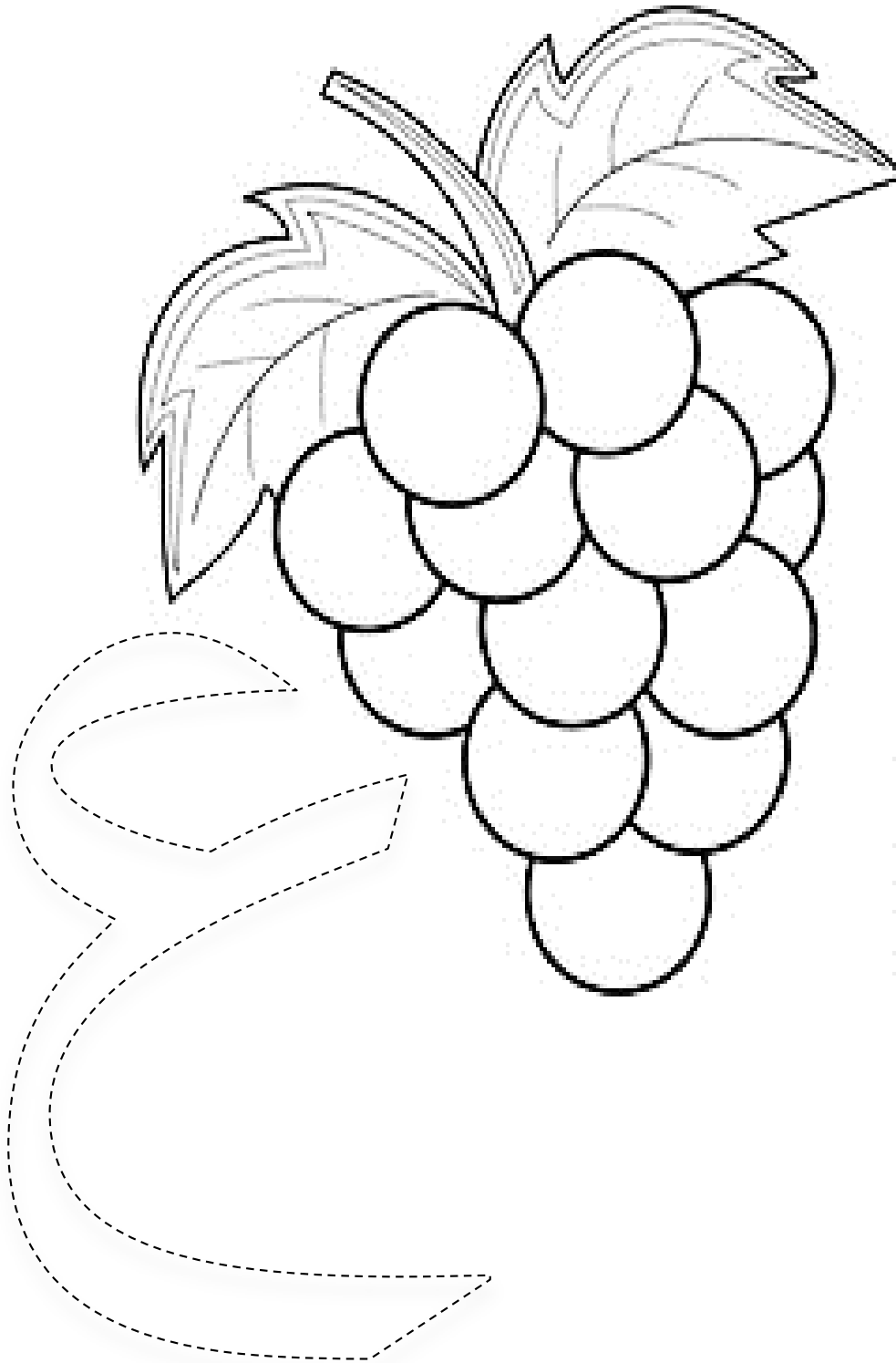

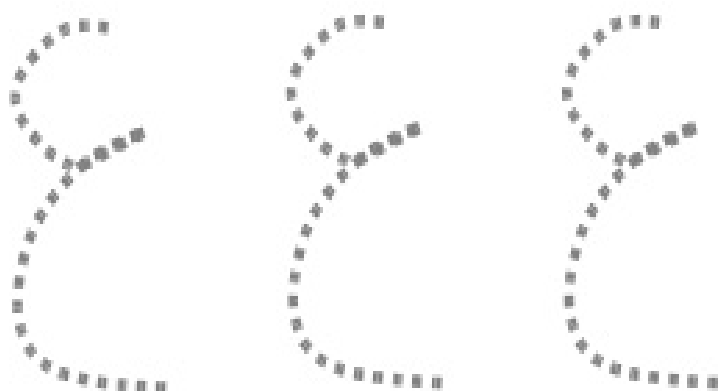
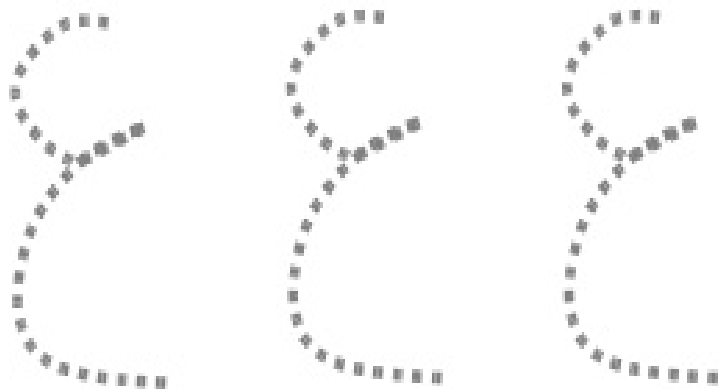

## EXERCISE 62: LETTER RECOGNITION

Join the dots and write the letter



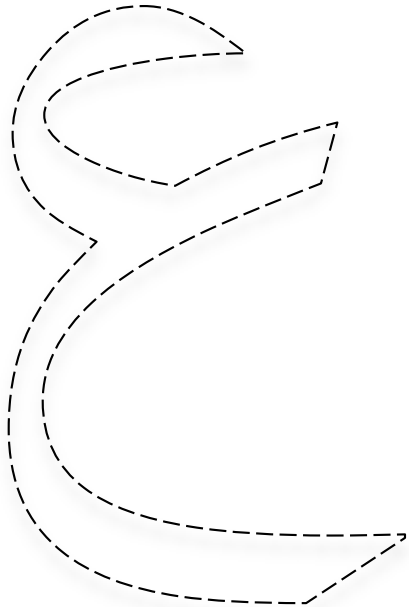

EXERCISE 63: LETTER RECOGNITIONChoose the matching letter below

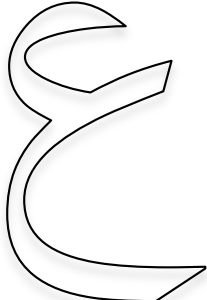
EXERCISE 64: LETTER RECOGNITION

GHAYN (gha)

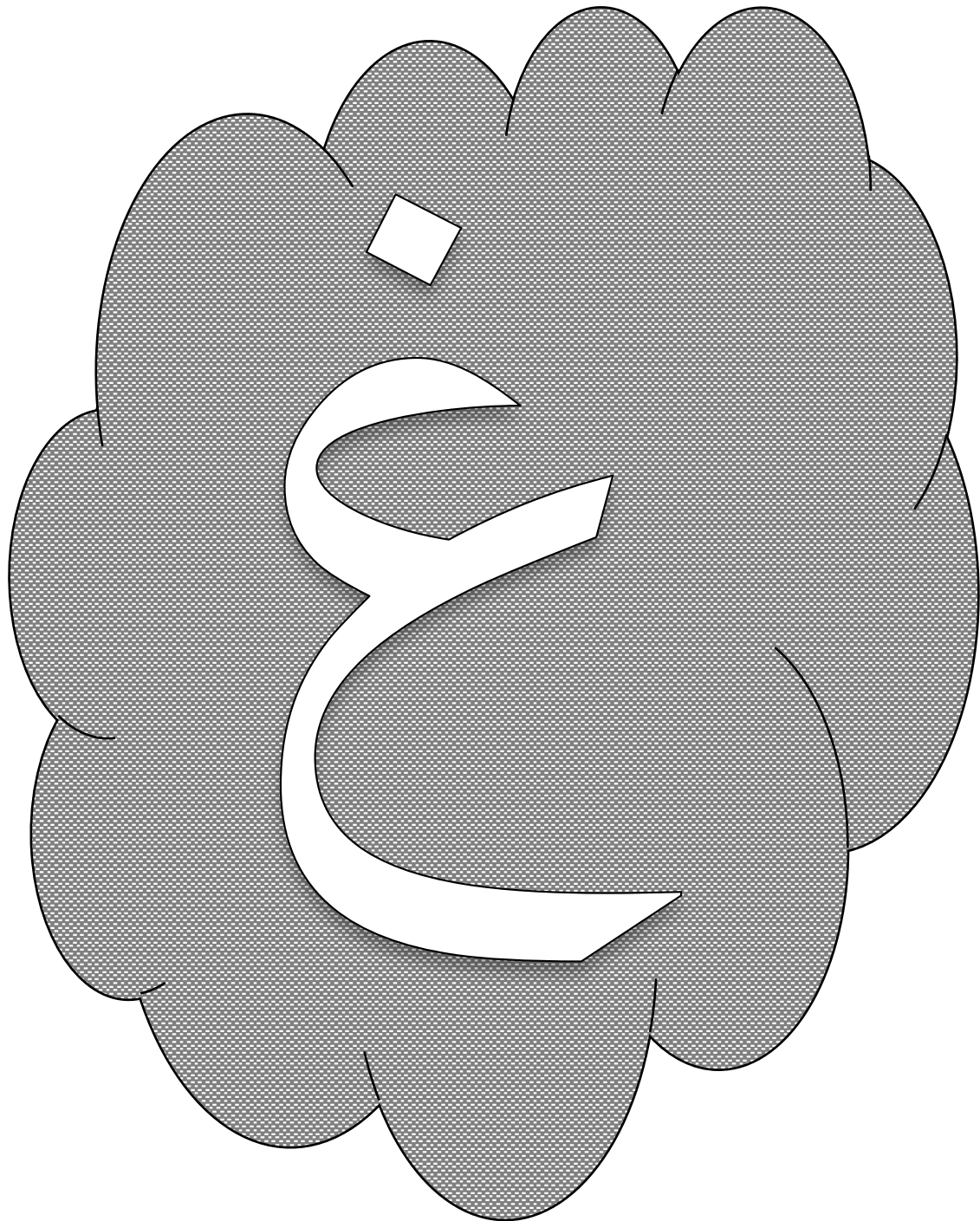

EXERCISE 65: LETTER RECOGNITION

Ghayn (gha)

غَايِنٌ  
اِغْيَا  
غَايِنٌ

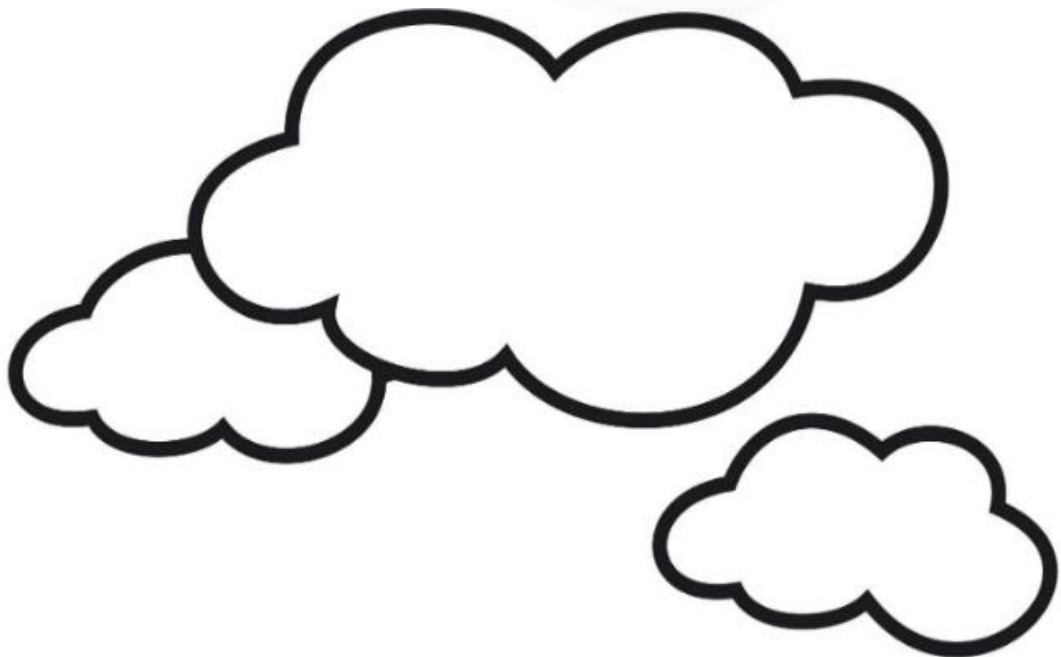
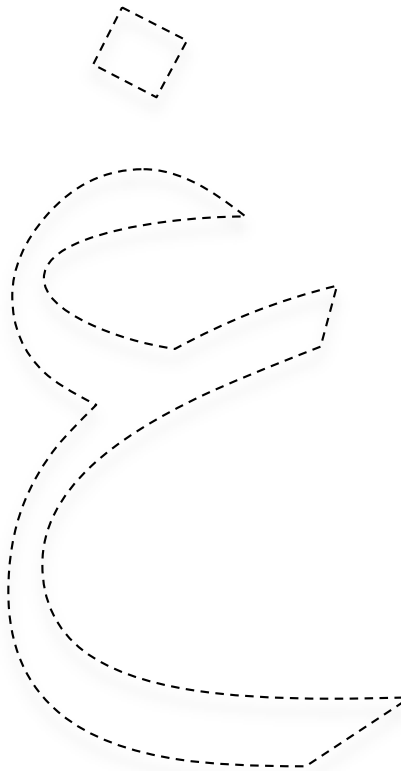

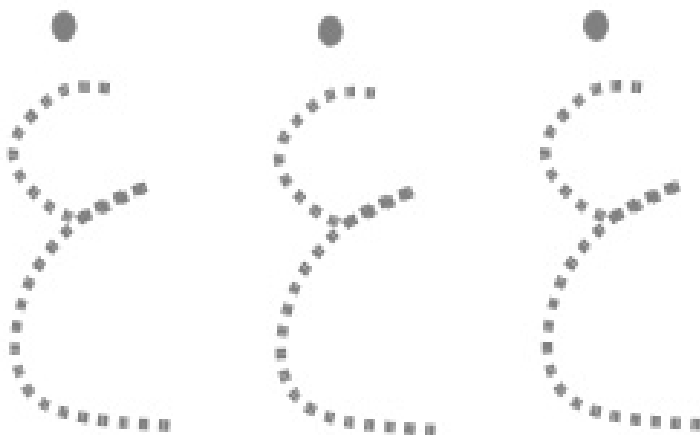
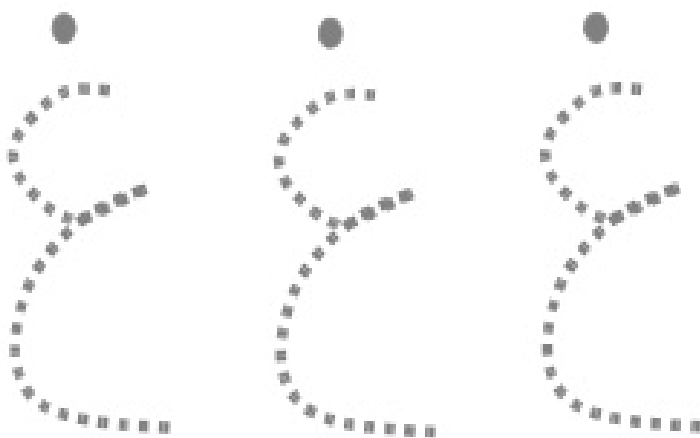

## EXERCISE 66: LETTER RECOGNITION

Join the dots and write the letter

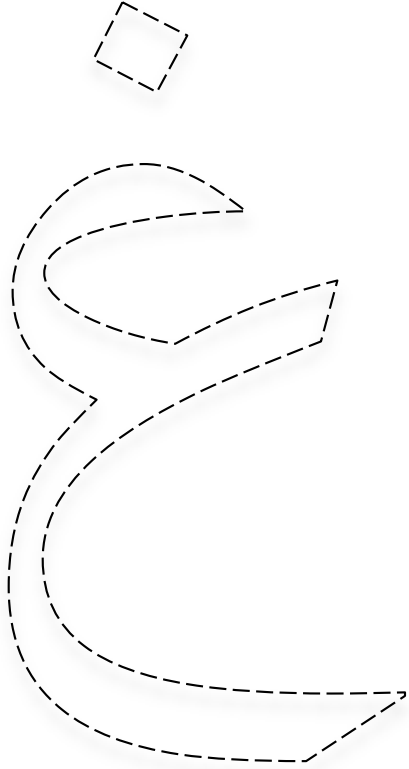

# EXERCISE 67: LETTER RECOGNITION

Choose the matching letter below

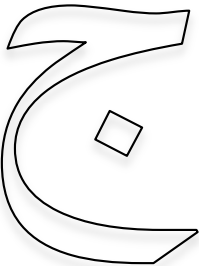
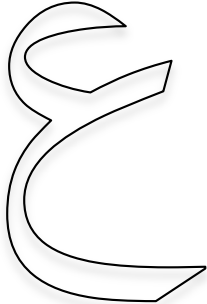
EXERCISE 68: LETTER RECOGNITION

FE

(fa)

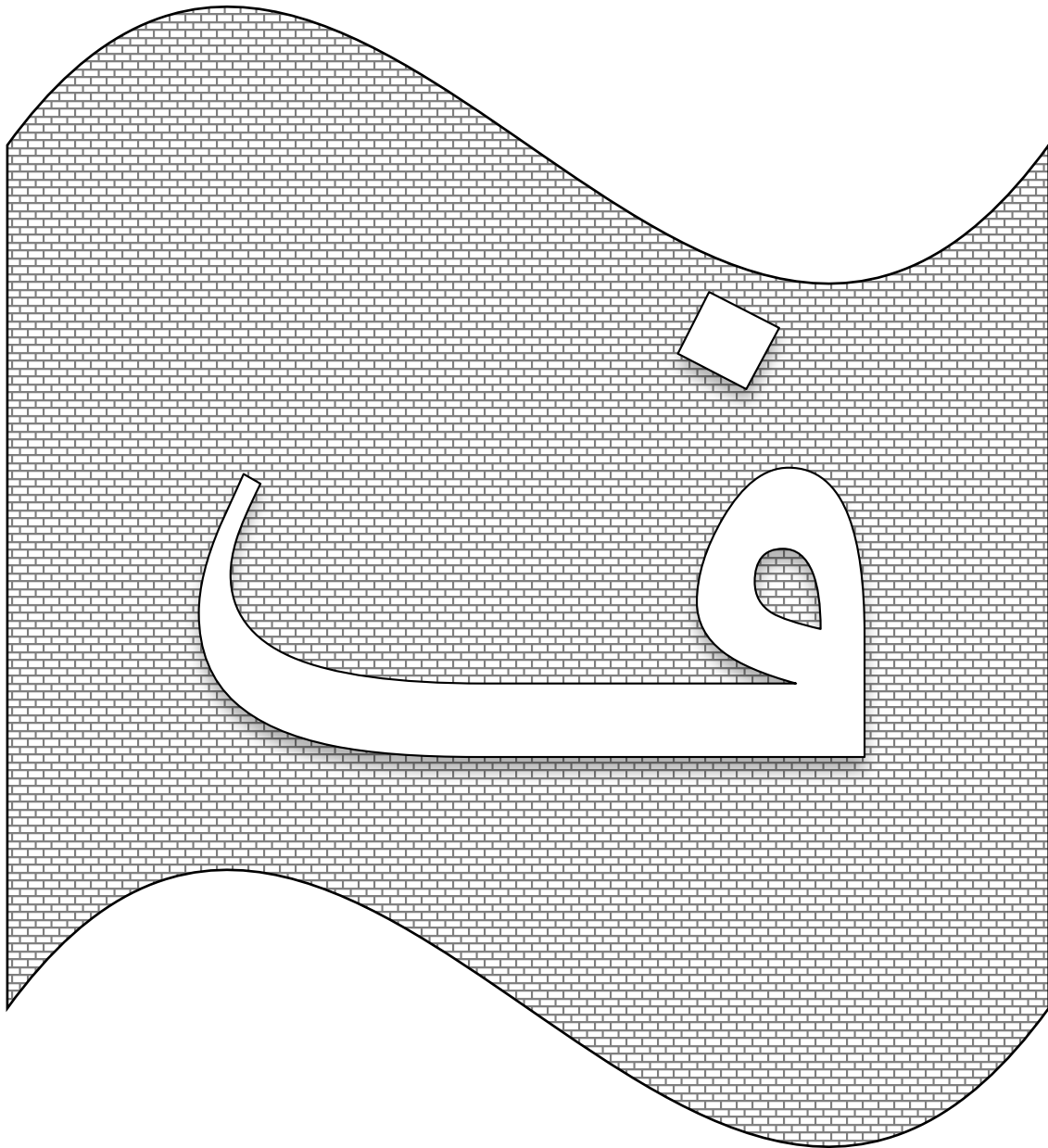

EXERCISE :69 LETTER RECOGNITION

F e ف ا ر (fa)

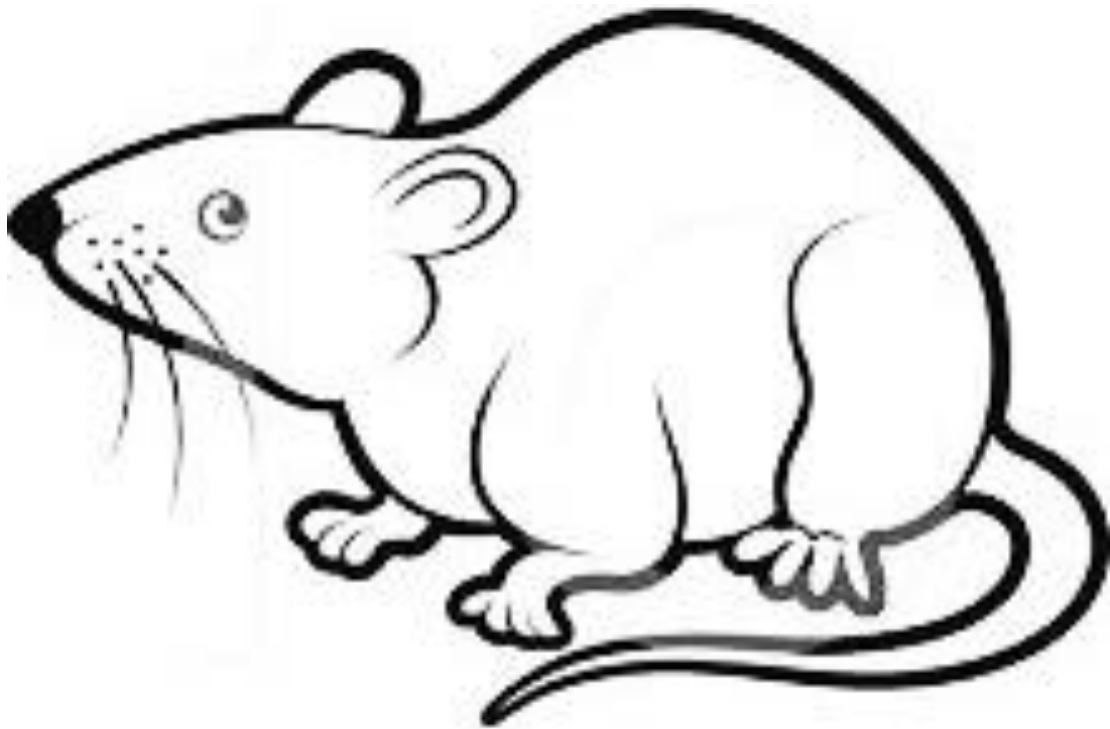
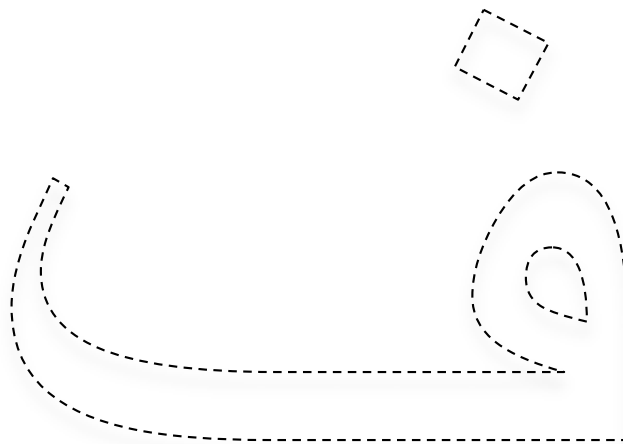

# EXERCISE 70: LETTER RECOGNITION

Join the dots and write the letter

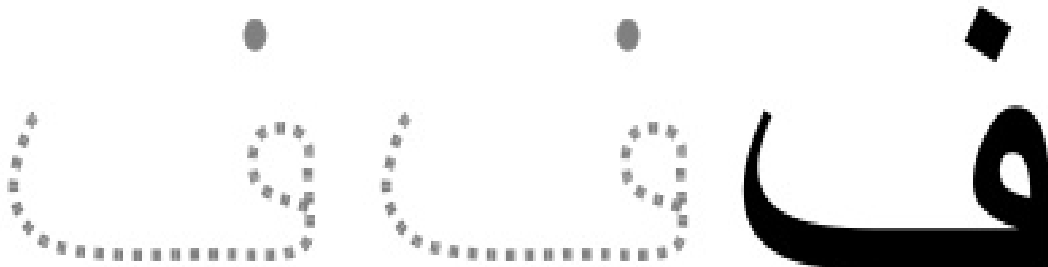
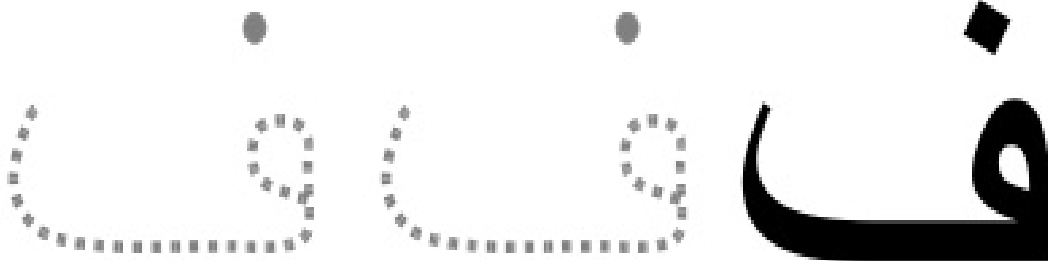
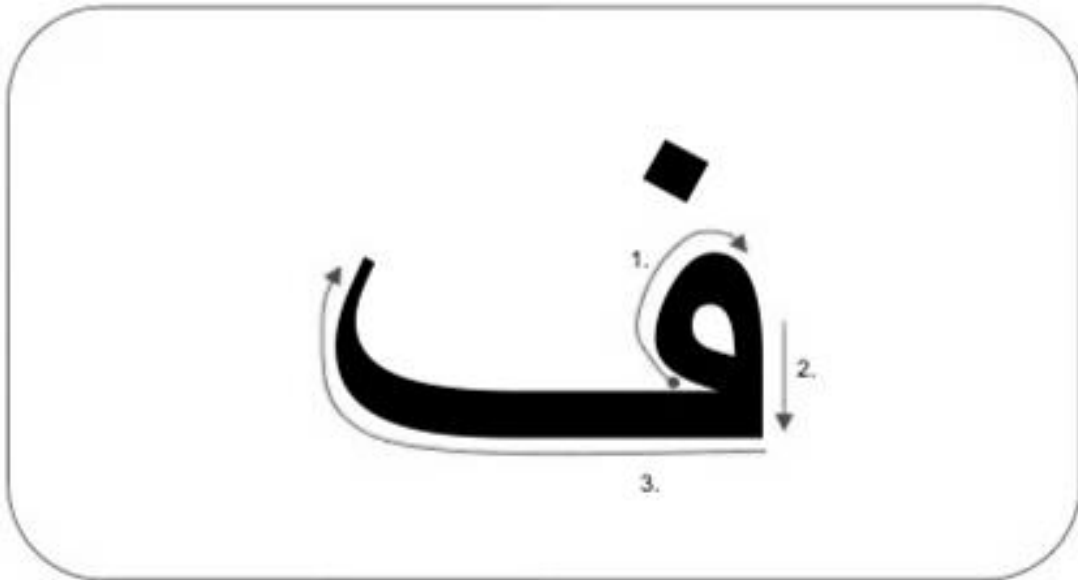



# EXERCISE 71: LETTER RECOGNITION

Choose the matching letter below

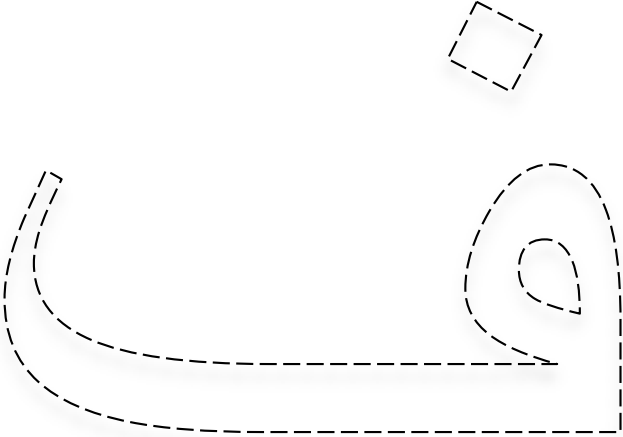
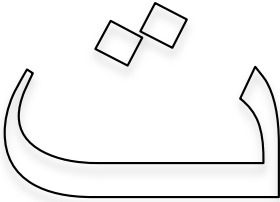
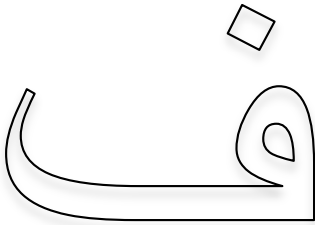
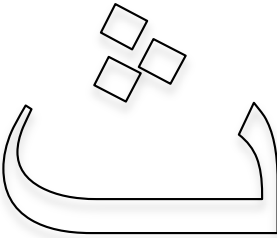
EXERCISE 72: LETTER RECOGNITION

QAF

(Qa)



EXERCISE 73: LETTER RECOGNITION

Qaf ق ف ق م (Qa)

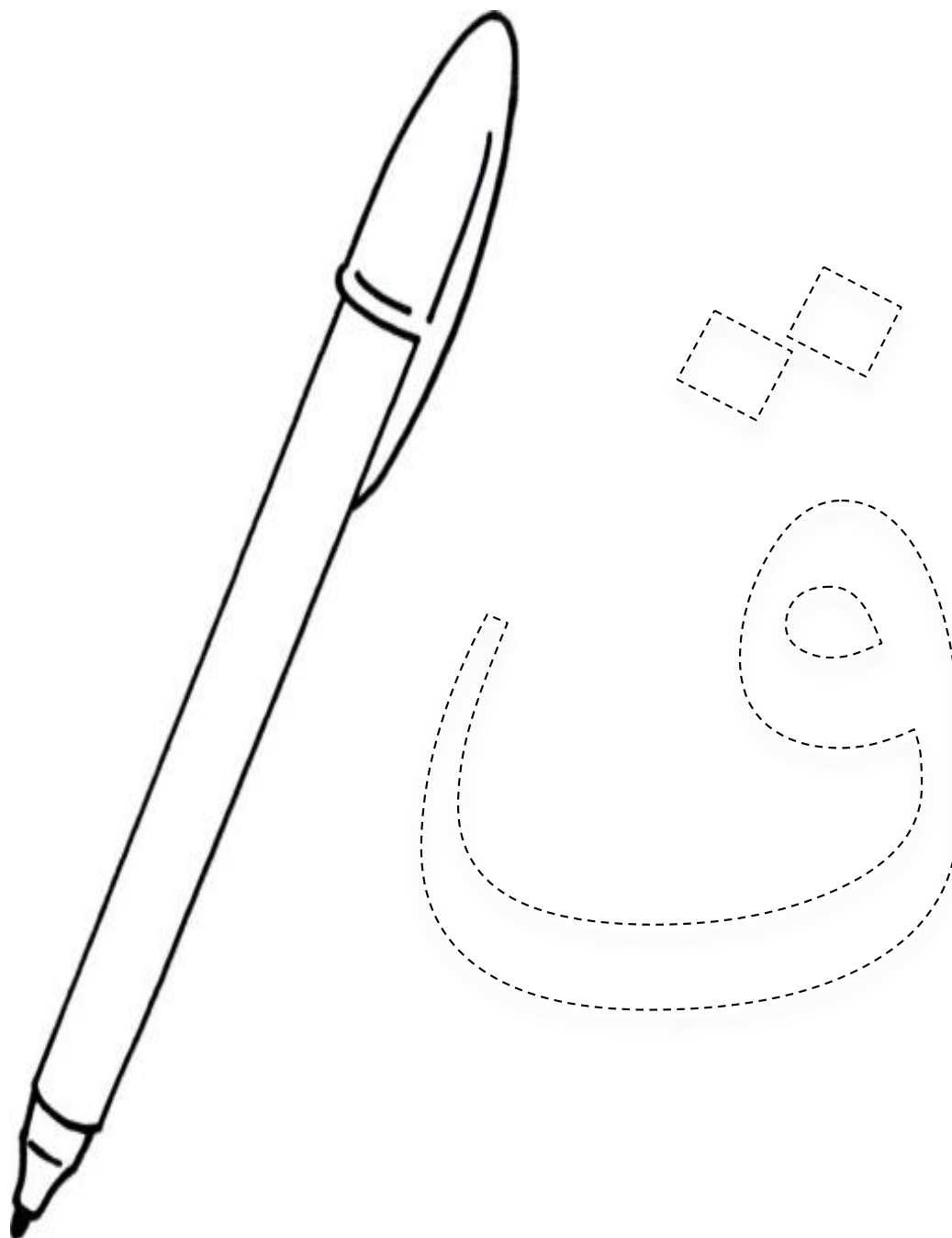

## EXERCISE 74: LETTER RECOGNITION

Join the dots and write the letter

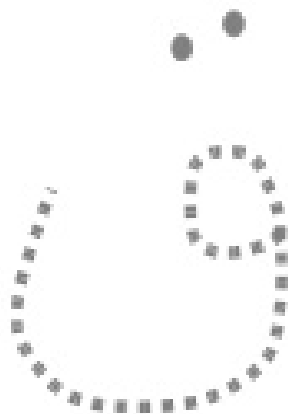
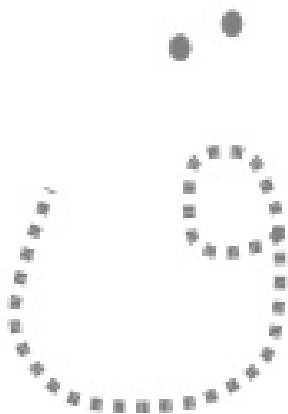
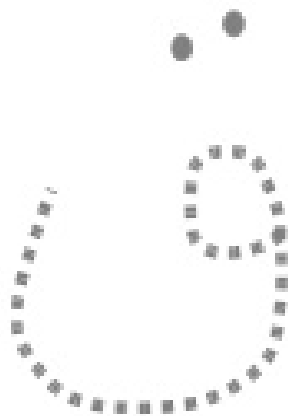
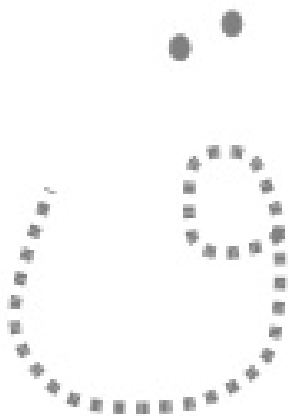

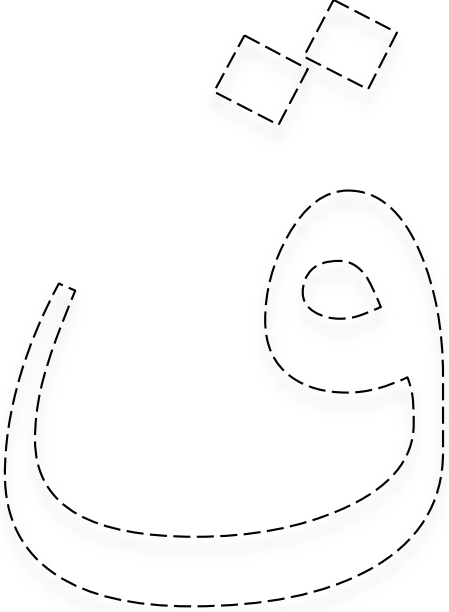
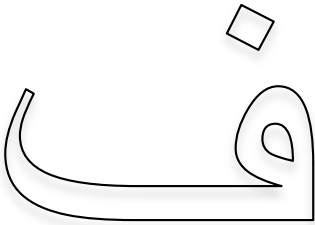
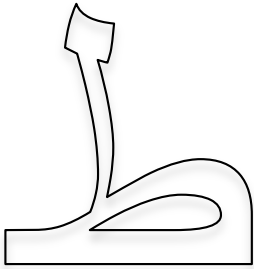
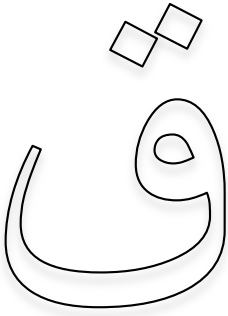

# EXERCISE 75: LETTER RECOGNITION

Choose the matching letter below

EXERCISE 76: READING EXERCISERECOGNISING LETTERS ع TO ق (AYN - QAF)

Read and identify the alphabets

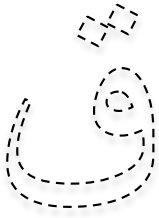
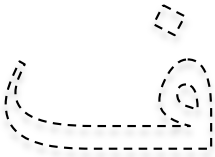
ق	ف	غ	ع
Qaf (Qa)	Fe (fa)	Ghayn (gha)	Ayn (a-heavy)
			

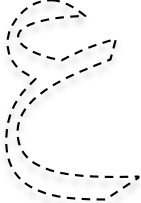
EXERCISE 77: READING EXERCISE

غ	ق	ظ	ف
ع	غ	ف	ق
ق	ع	ا	غ

EXERCISE 78: LETTER RECOGNITIONCircle the correct matching letter as shown

ذ	ع	ث	=	ع
ر	ض	غ	=	غ
ف	د	غ	=	ف
ع	ظ	ف	=	ف

EXERCISE 79: JOIN THE MATCHING LETTERS

ن      ع

و      ن

و      و

ع      و









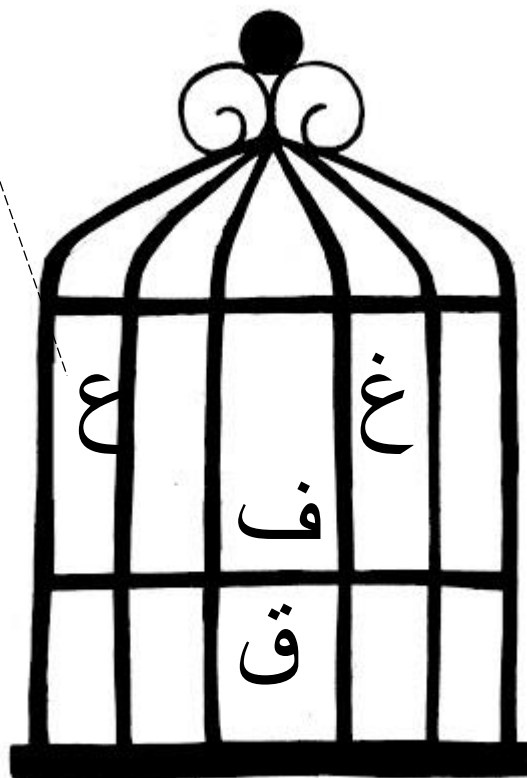
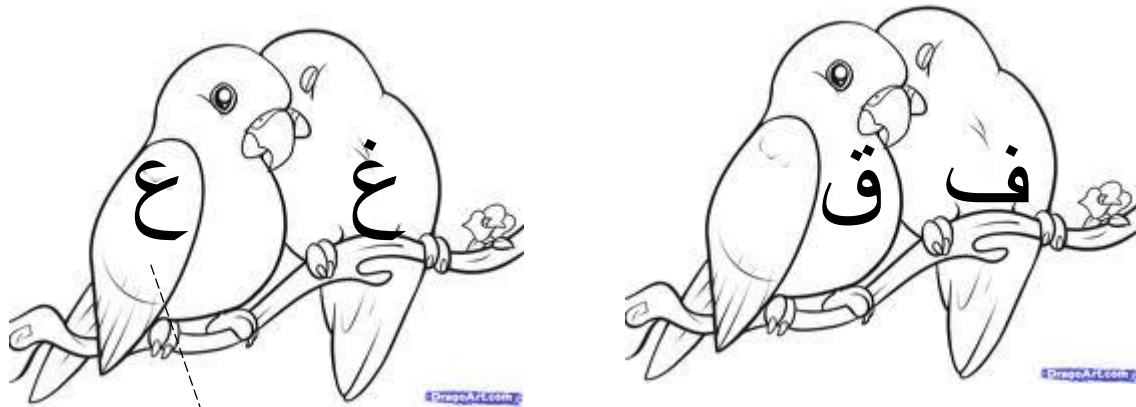



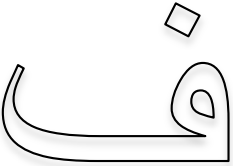

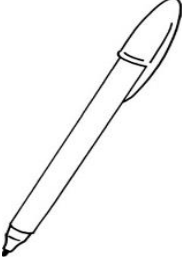
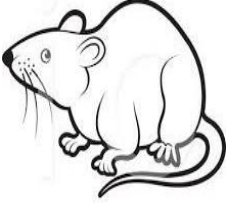
EXERCISE 80: JOINING EXERCISE

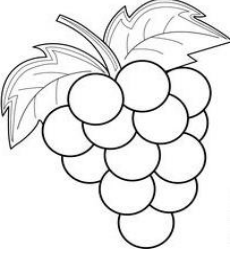
RECOGNISING LETTERS ع TO ق (AYN - QAF)

Match the birds with the correct letter in the cage



**EXERCISE 81: WRITING EXERCISE****Join the dots and write the letter**

QAF (Qa)	FE (fa)	GHAYN (gha)	AYN (a-heavy)
			
			
			
			

EXERCISE 82: LETTER RECOGNITION

KAF

(ka)

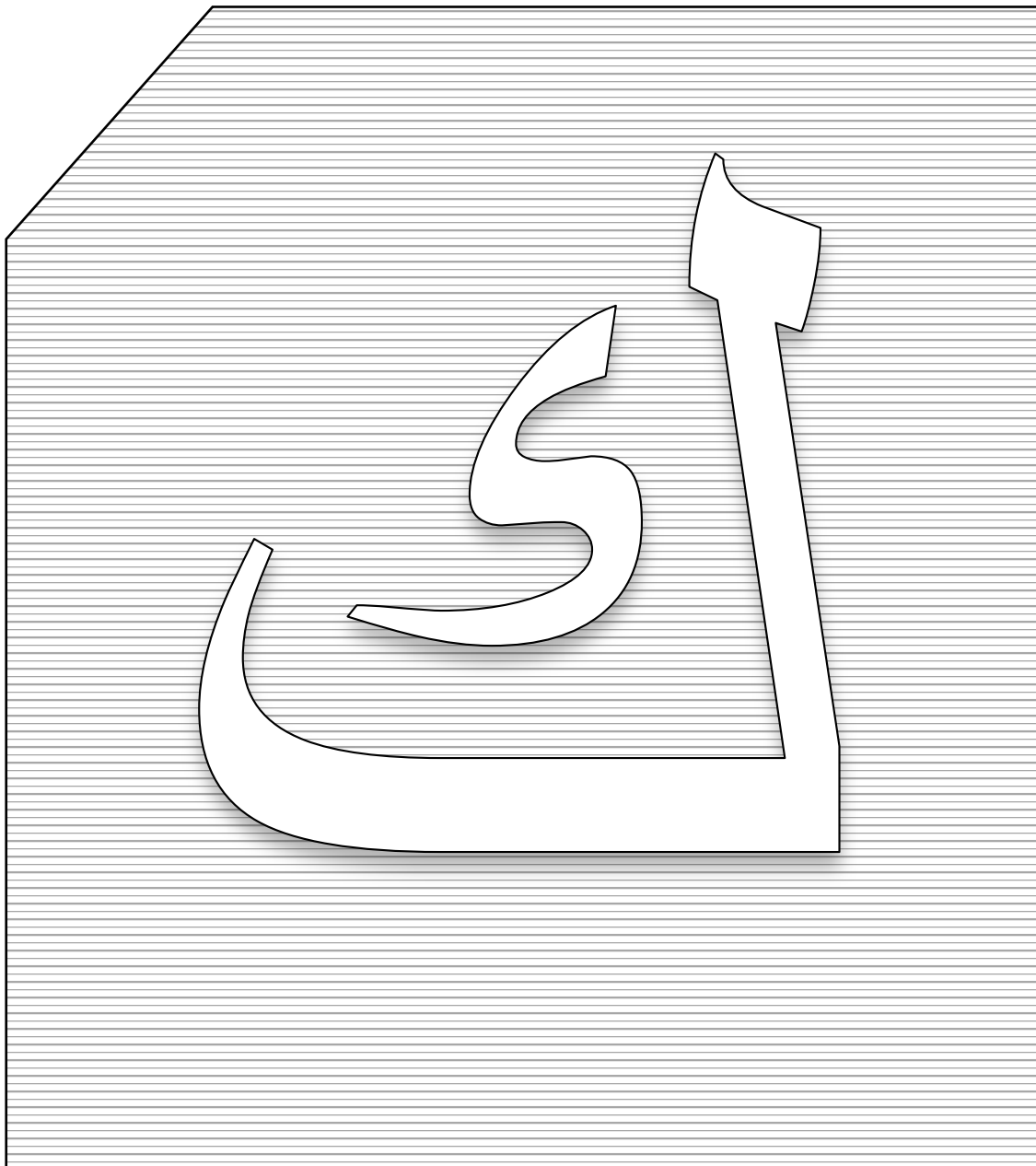

EXERCISE 83: LETTER RECOGNITION

Kaf ك (ka) ع ب ه

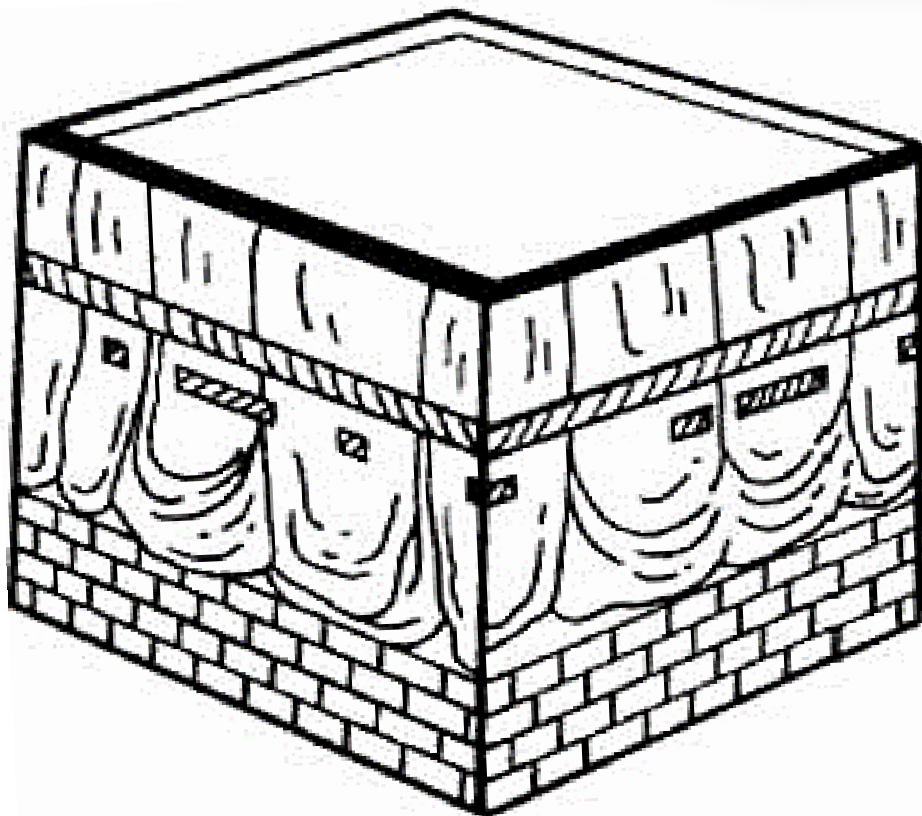
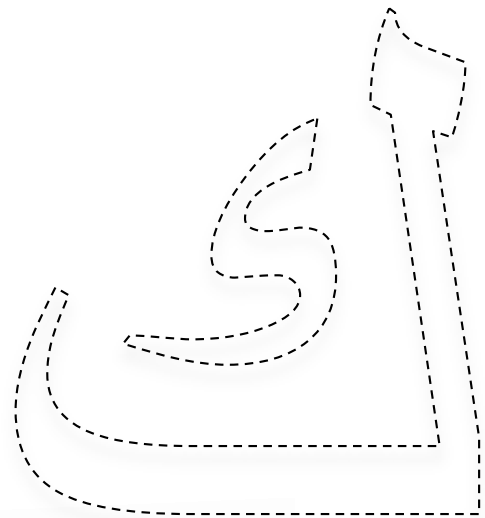

EXERCISE 84: LETTER RECOGNITION

Join the dots and write the letter

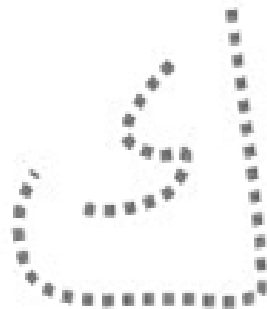
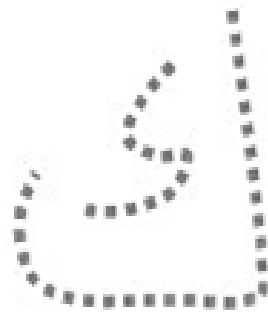
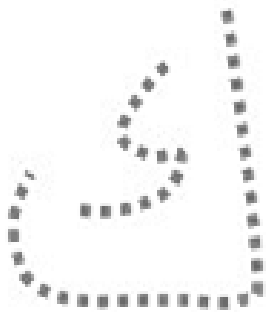
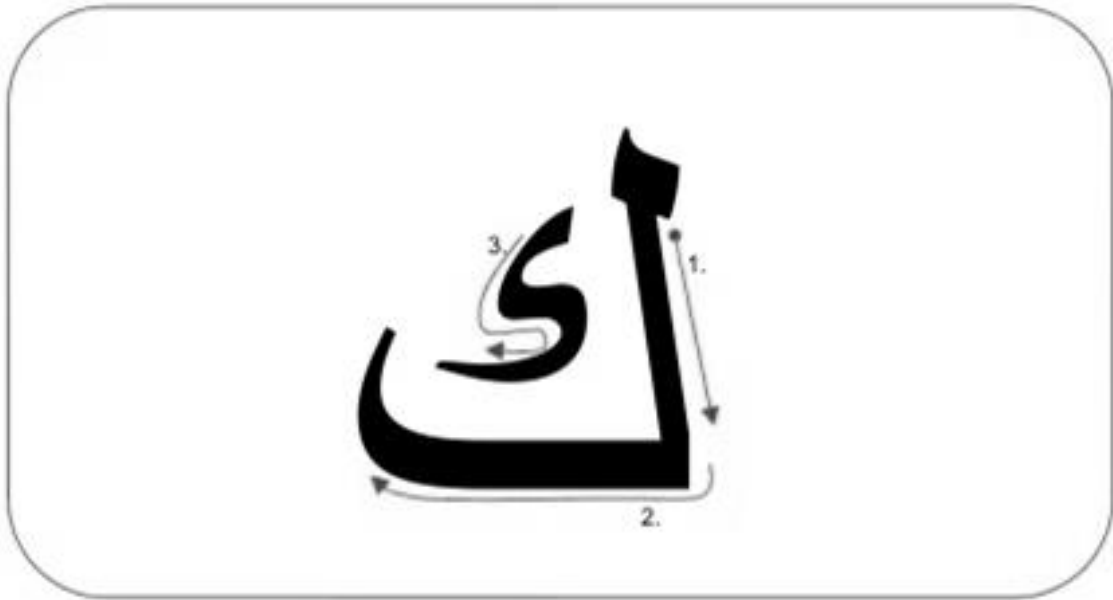

**EXERCISE 85: LETTER RECOGNITION**

Choose the matching letter below

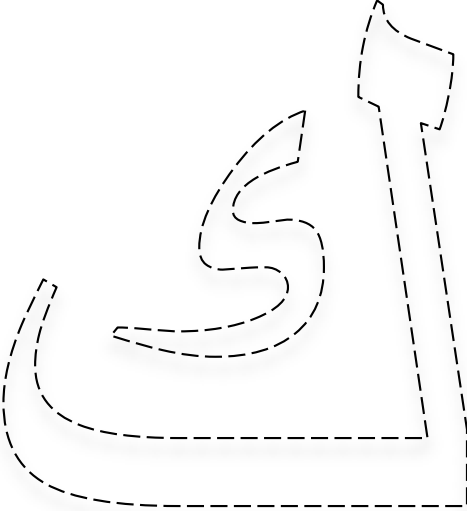
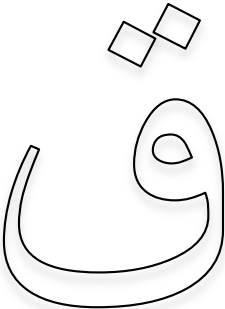
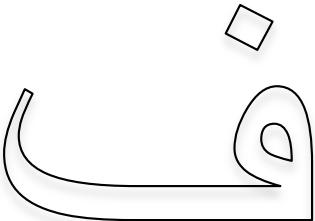
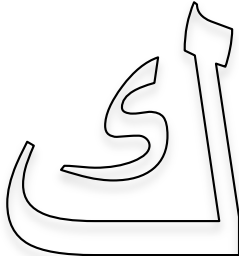
EXERCISE 86: LETTER RECOGNITION

LAM

(La)

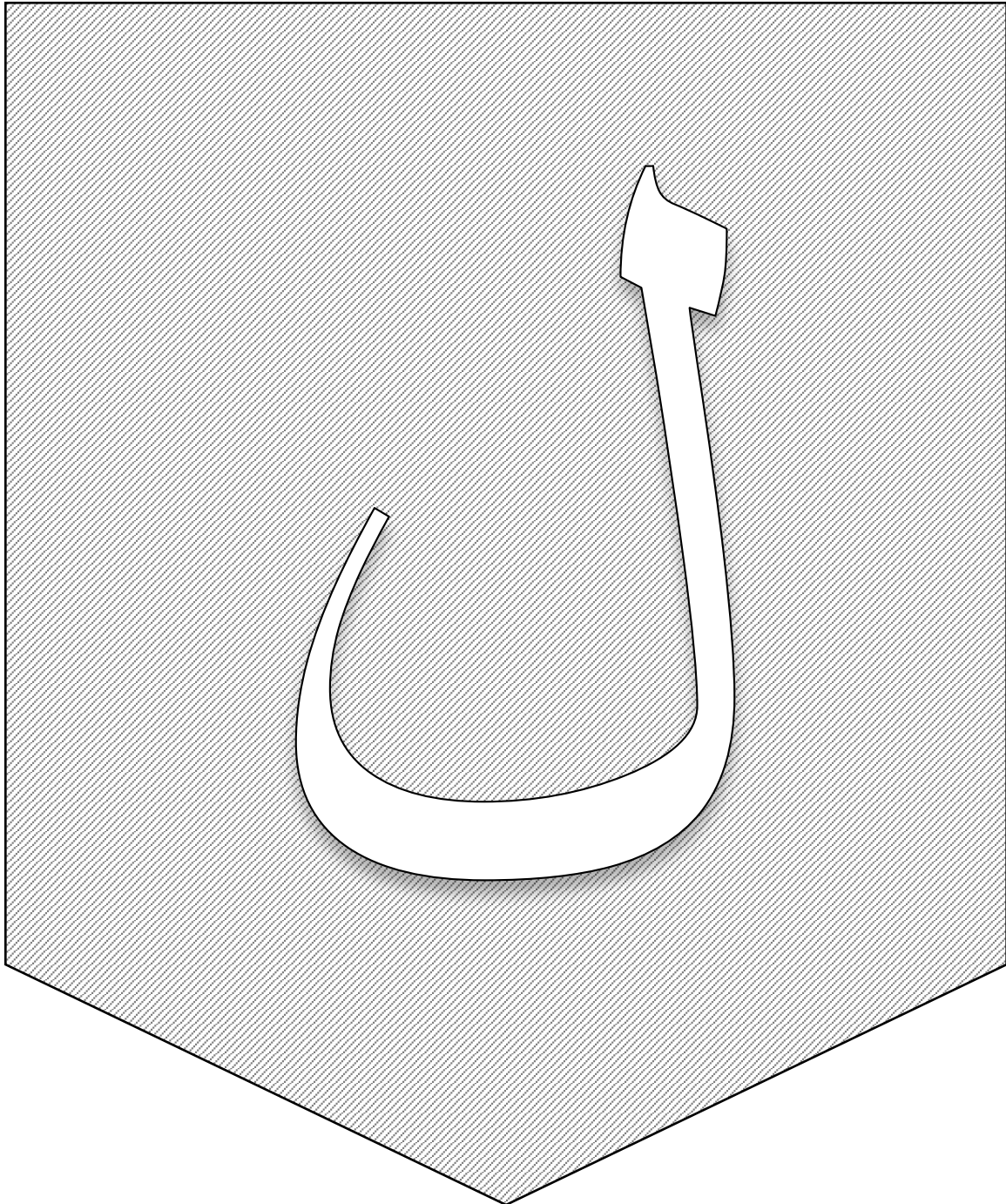

EXERCISE 87: LETTER RECOGNITION

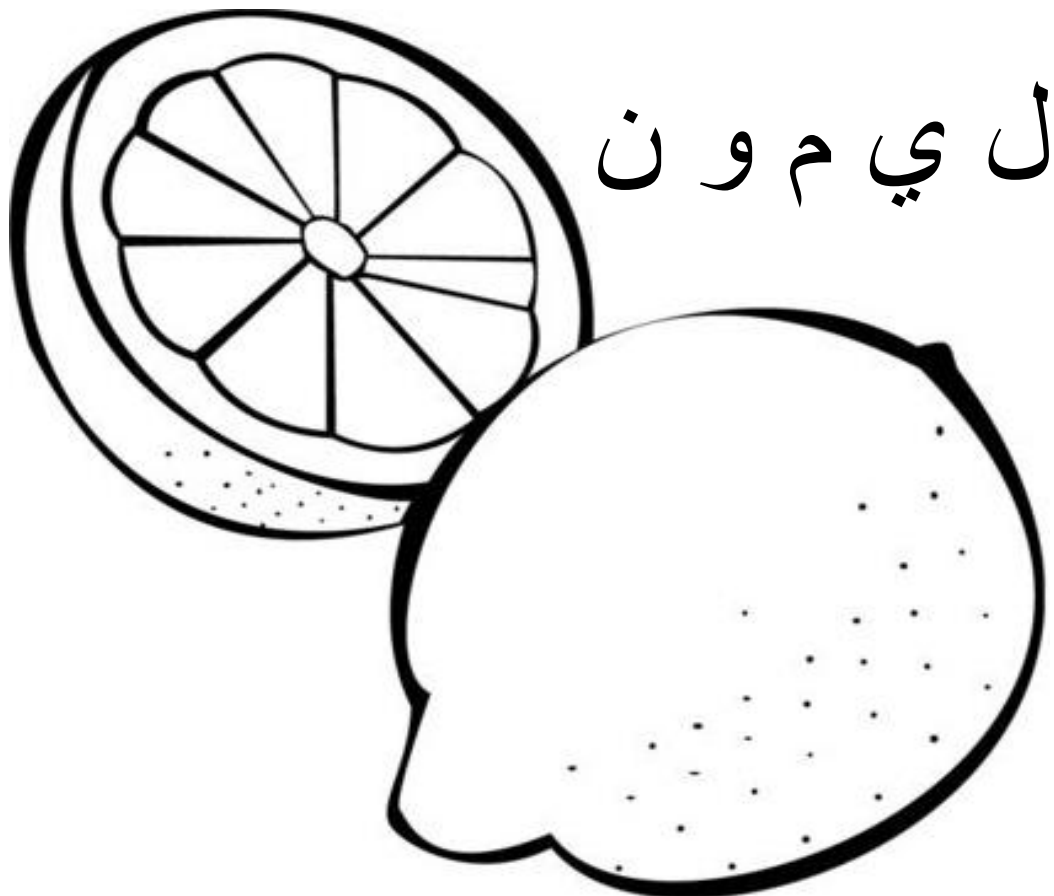
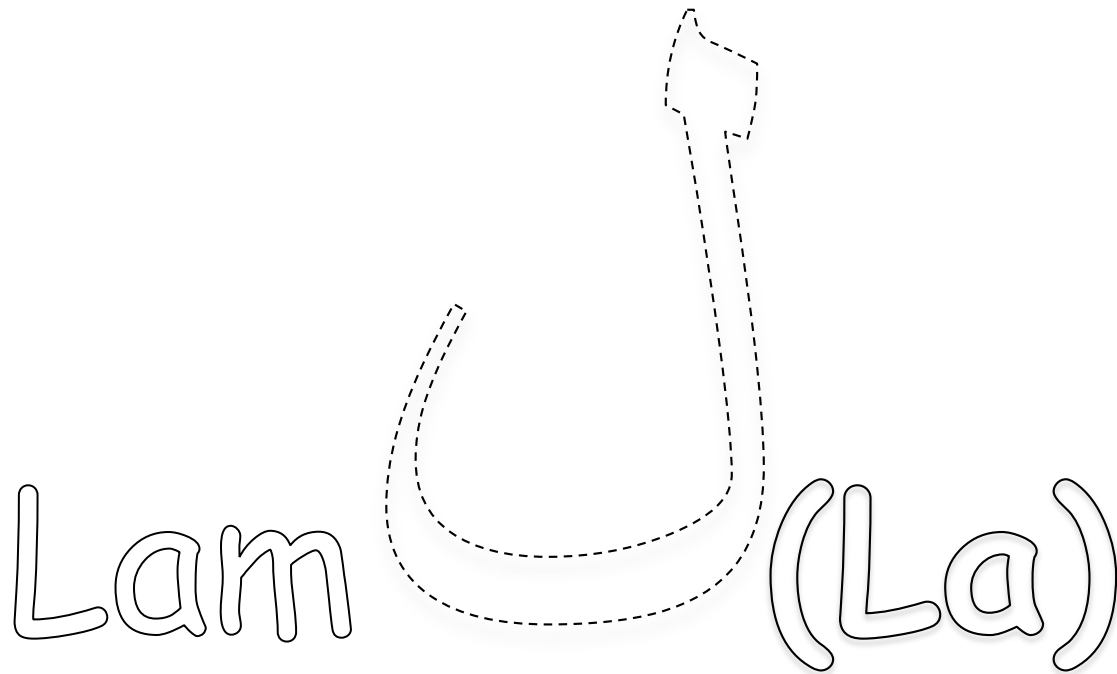



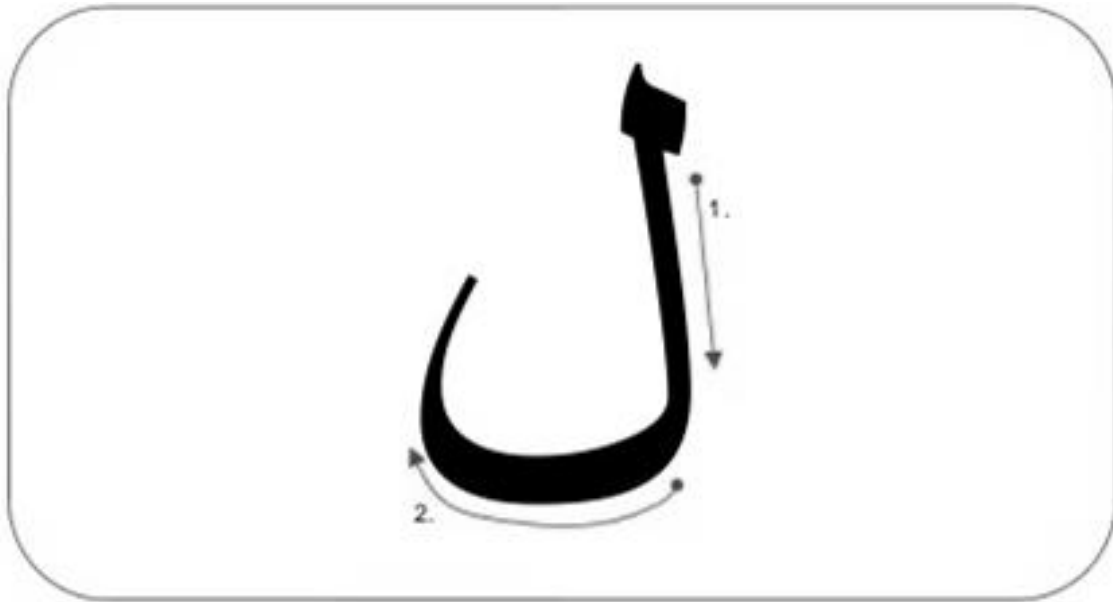

# EXERCISE 88: LETTER RECOGNITION

Join the dots and write the letter

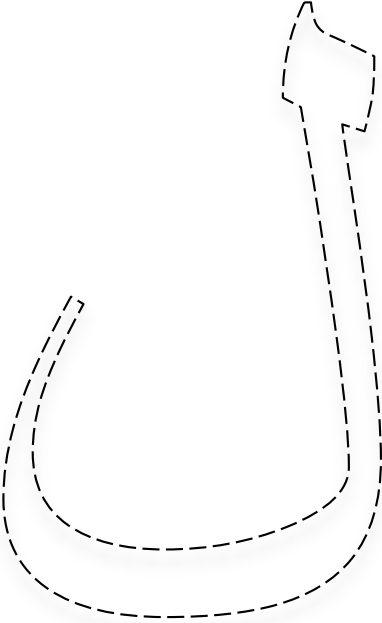
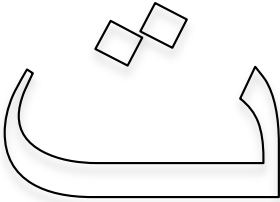

# EXERCISE 89: LETTER RECOGNITION

Choose the matching letter below

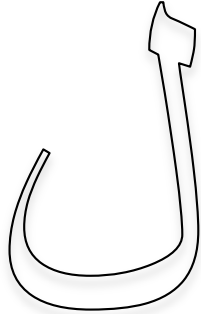
EXERCISE 90: LETTER RECOGNITION

MIM (ma)

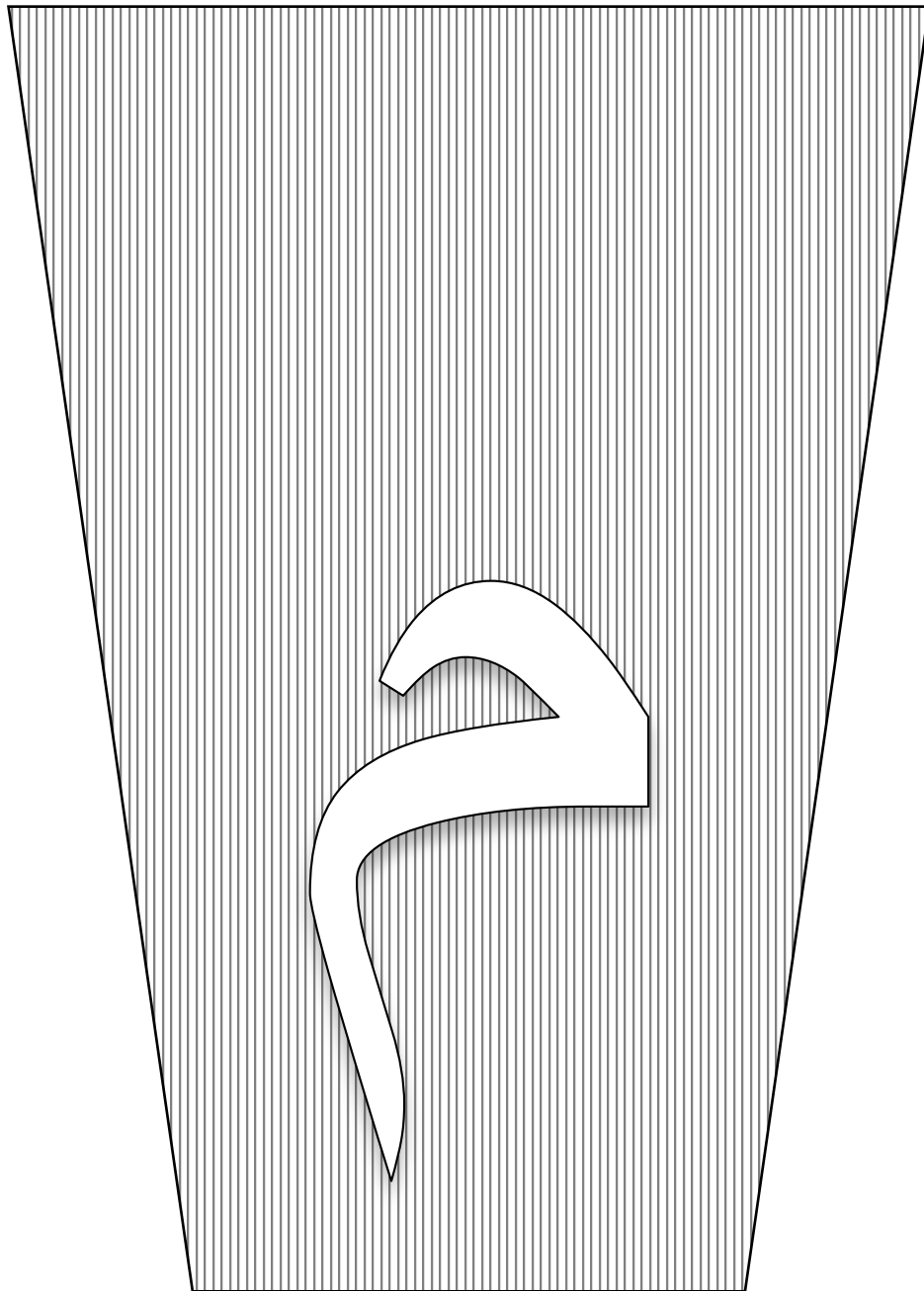

EXERCISE 91: LETTER RECOGNITION

مَ و ز

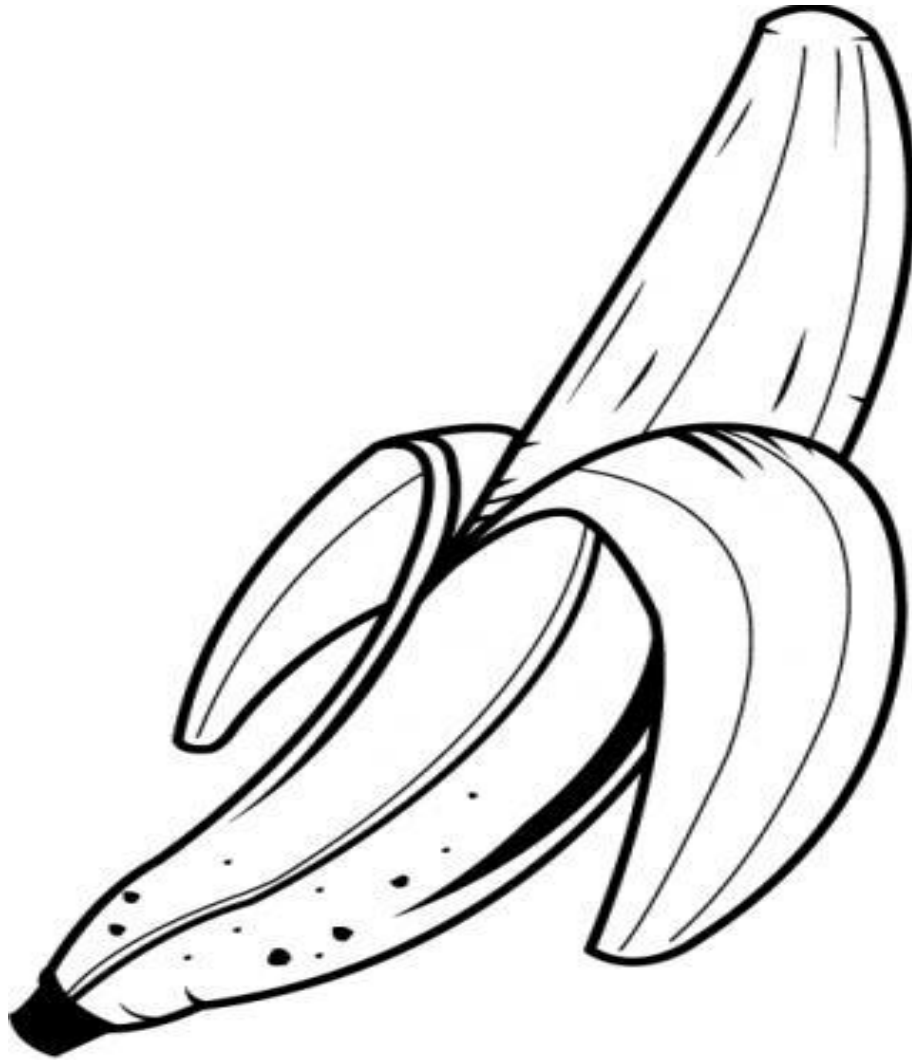

Mim

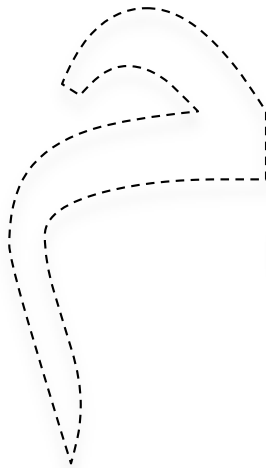

(ma)

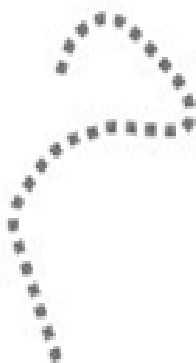
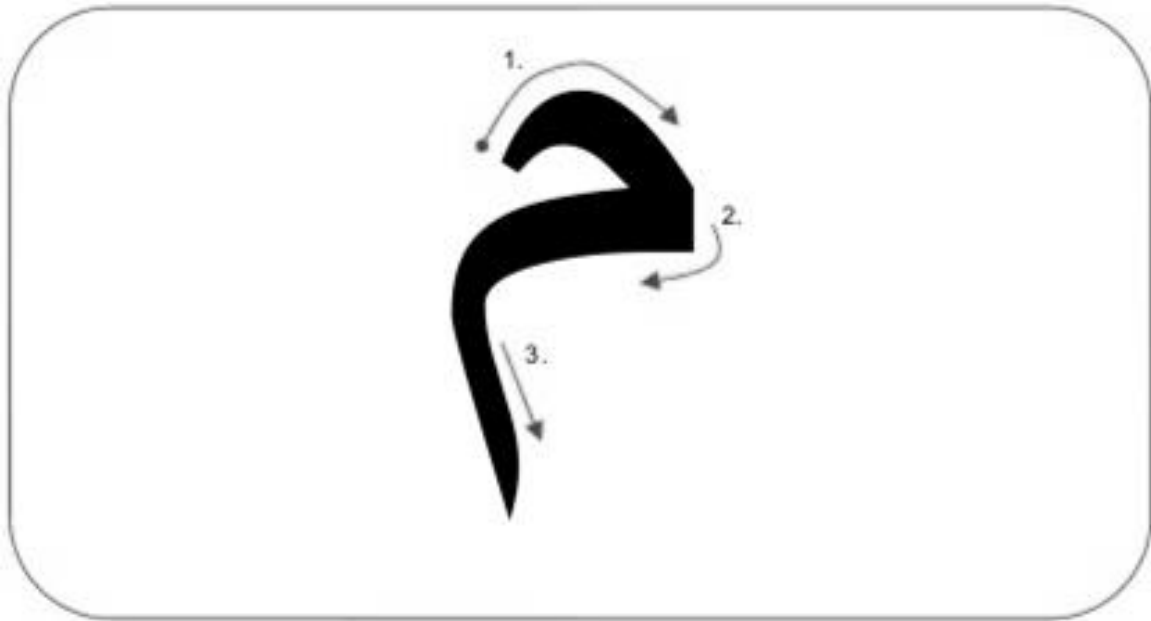

## EXERCISE 92: LETTER RECOGNITION

Join the dots and write the letter

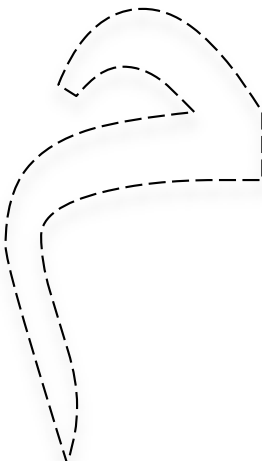

**EXERCISE 93: LETTER RECOGNITION**

Choose the matching letter below

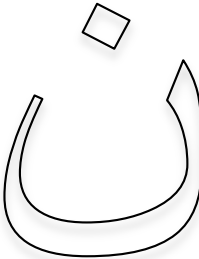
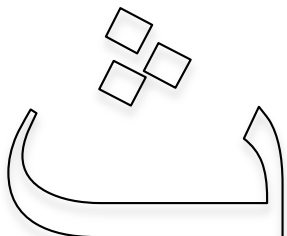
EXERCISE 94: LETTER RECOGNITION

NUN (na)

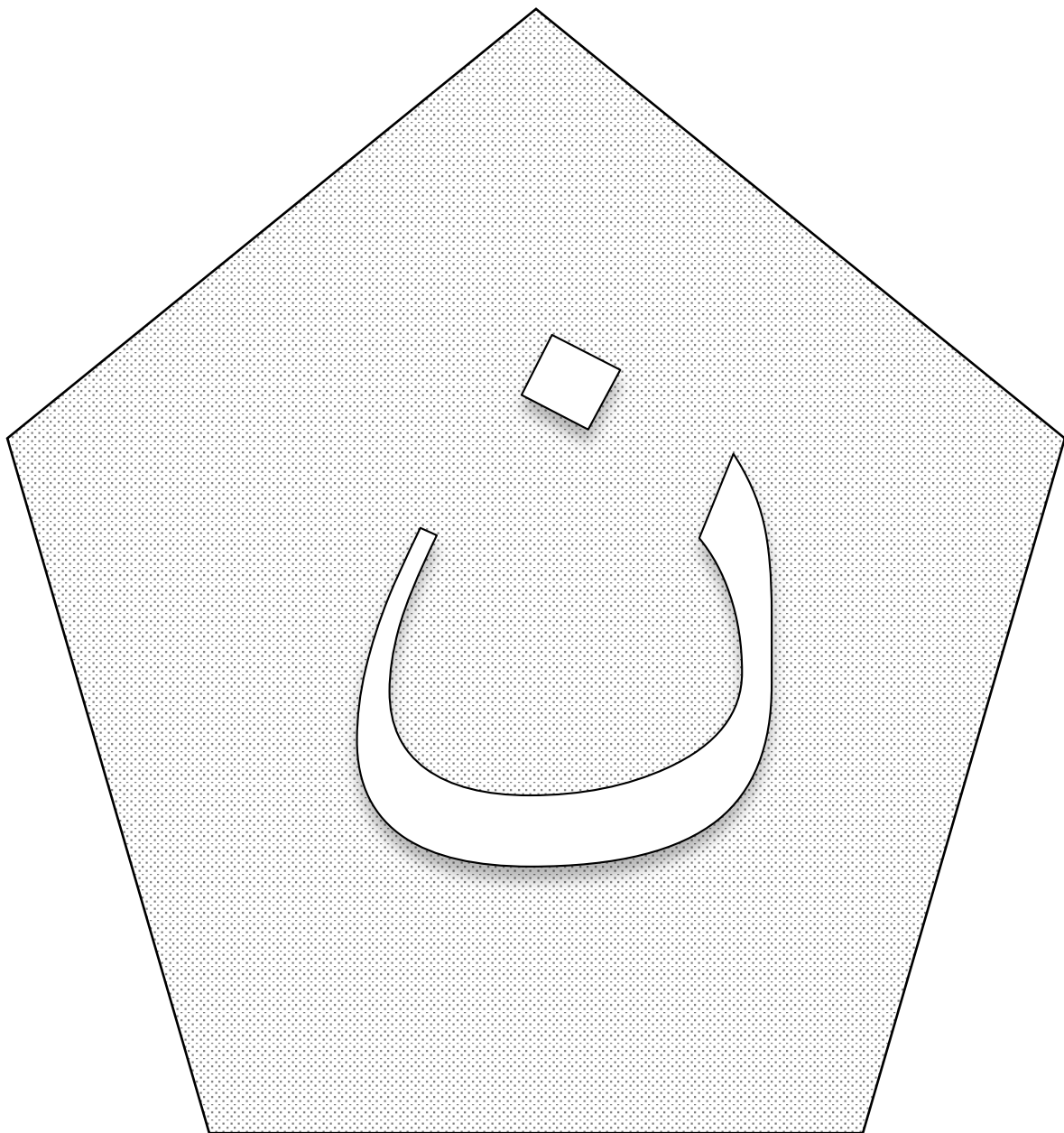

EXERCISE 95: LETTER RECOGNITION

Nun ن ح ن (na)

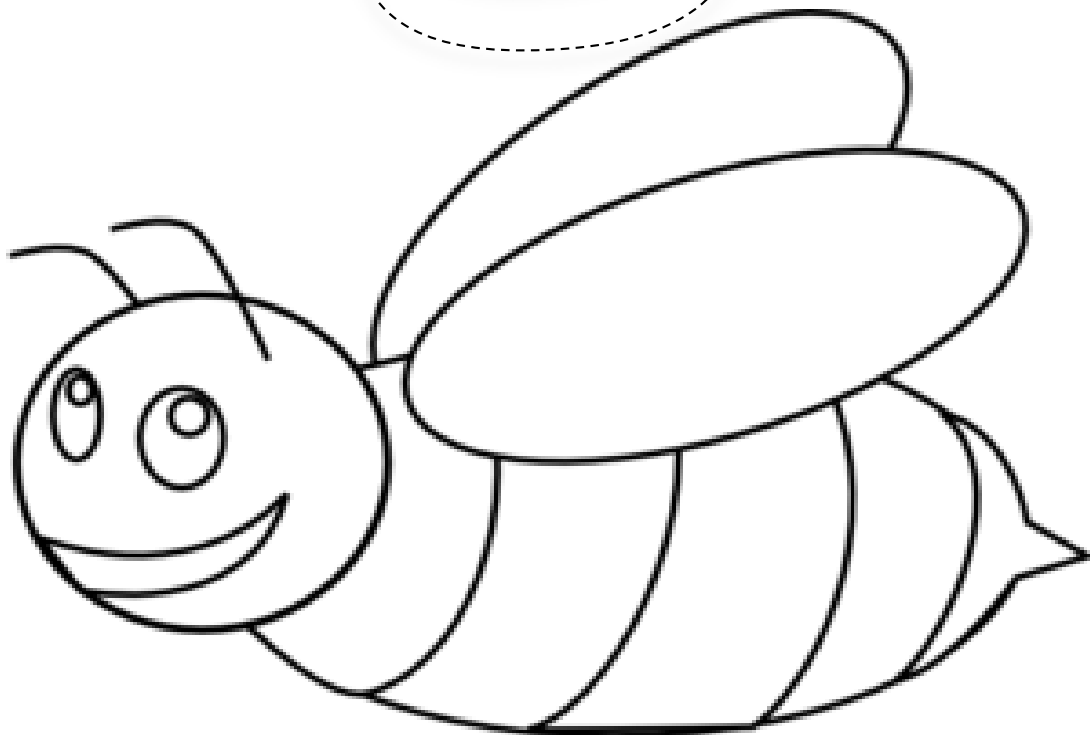
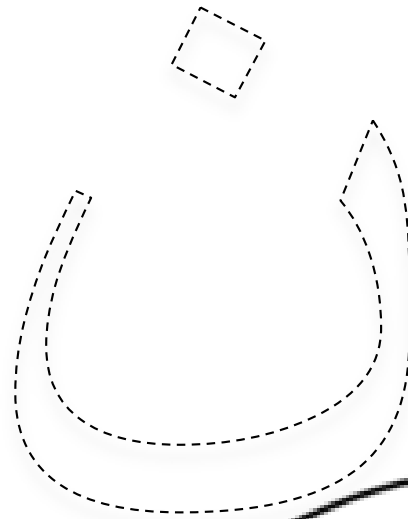



## EXERCISE 96: LETTER RECOGNITION

Join the dots and write the letter

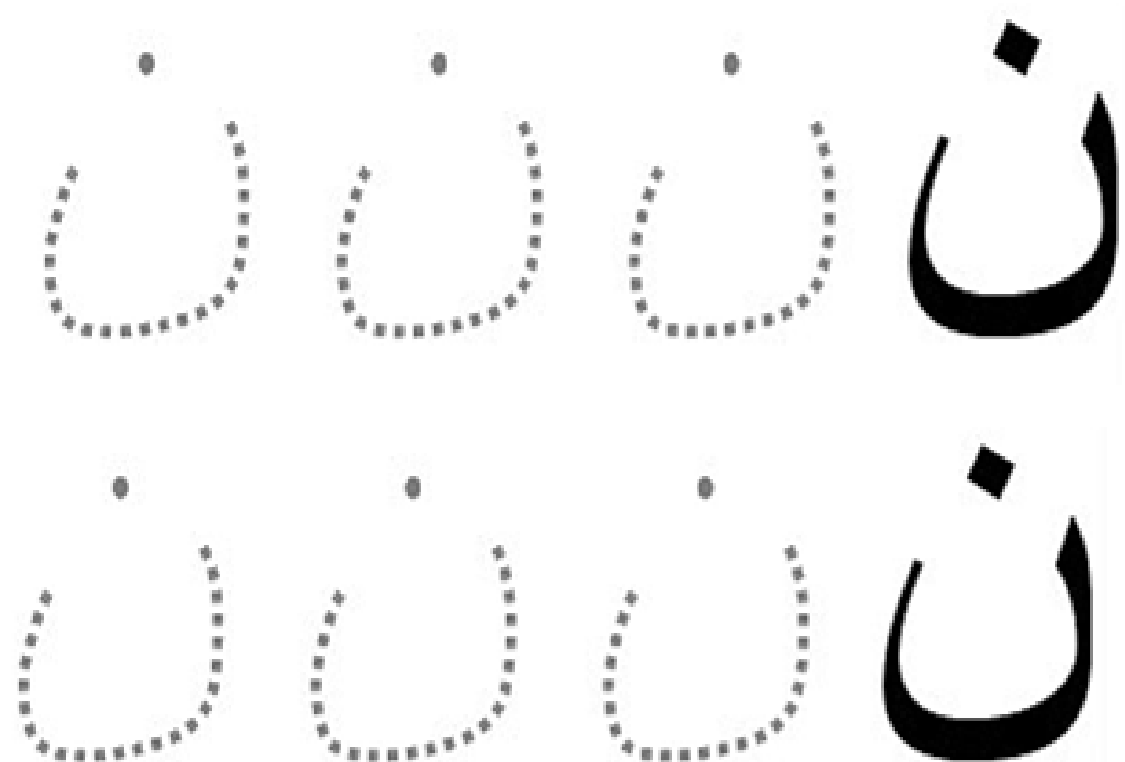
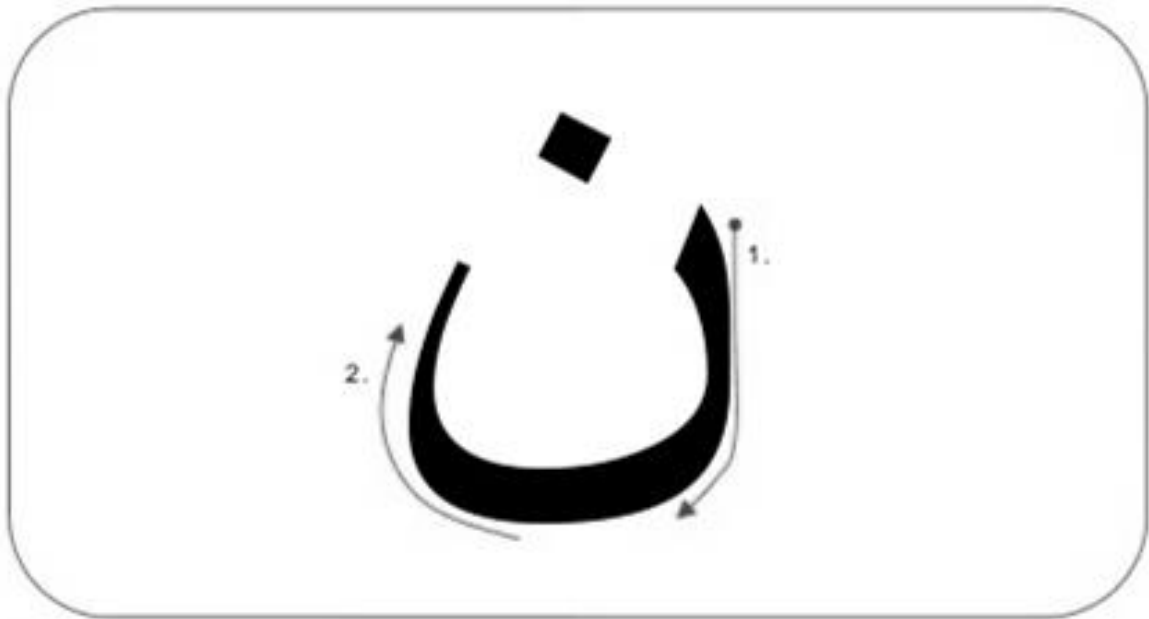



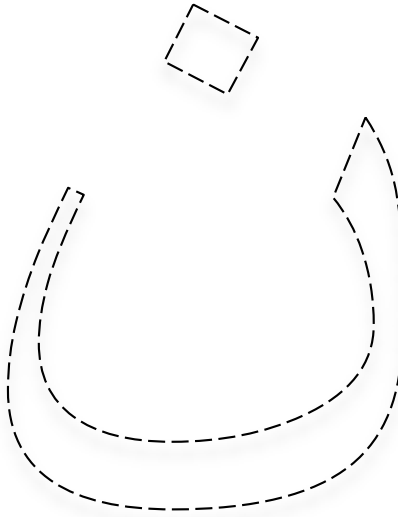
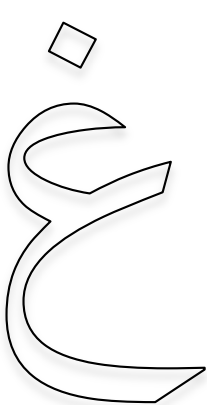
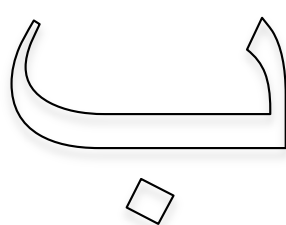
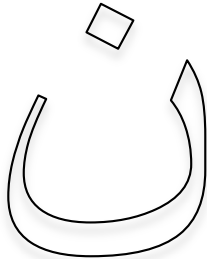

**EXERCISE 97: LETTER RECOGNITION**

Choose the matching letter below

EXERCISE 98: READING EXERCISERECOGNISING LETTERS ك TO ن (KAF - NUN)

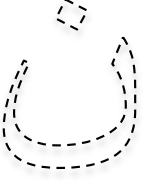
Read and identify the alphabets

ن	م	ل	ك
Nun (na)	Mim (ma)	Lam (La)	Kaf (ka)
			

EXERCISE 99: READING EXERCISE

ك	م	ن	ل
ل	ك	م	ن
ك	م	ن	ل

EXERCISE 100: LETTER RECOGNITIONCircle the correct matching letter as shown

ك = ع ذ ك

ل = ض ل ر

م = ف ك م

ن = م ن ف

EXERCISE 101: JOIN THE MATCHING LETTERS

ن

ك

م

ن

ن

ك

ك







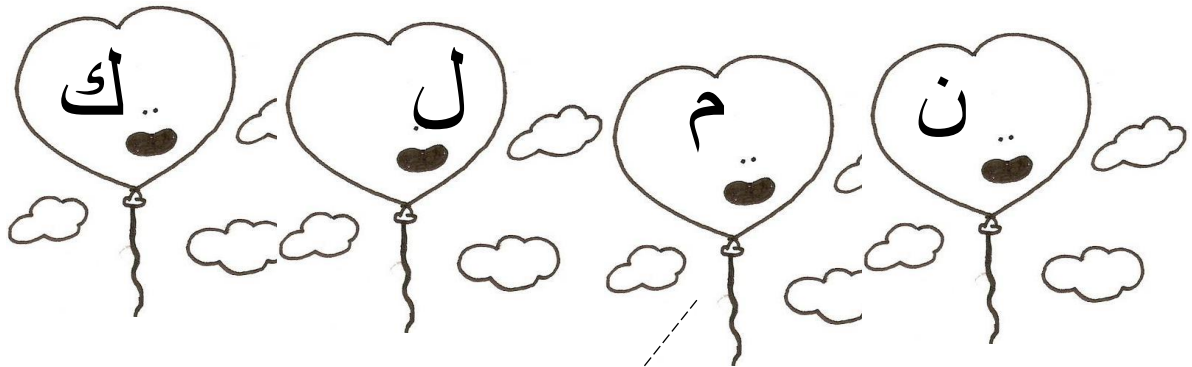



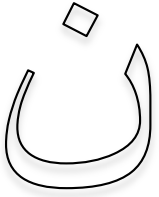

م

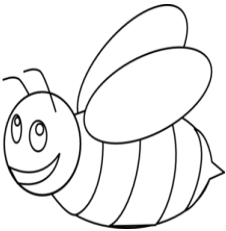
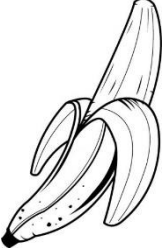
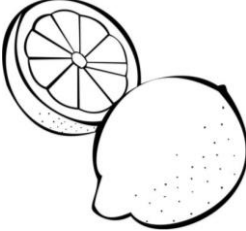
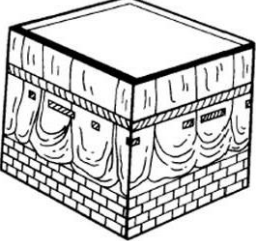
EXERCISE 102: JOINING EXERCISERECOGNISING LETTERS ك TO ن (KAF - NUN)

Match the balloons with the correct letter in the presents



**EXERCISE 103: WRITING EXERCISE****Join the dots and write the letter**

<b>NUN</b> (na)	<b>MIM</b> (ma)	<b>LAM</b> (La)	<b>KAF</b> (ka)
			
			
			
			

EXERCISE 104: LETTER RECOGNITION

WAW (wa)

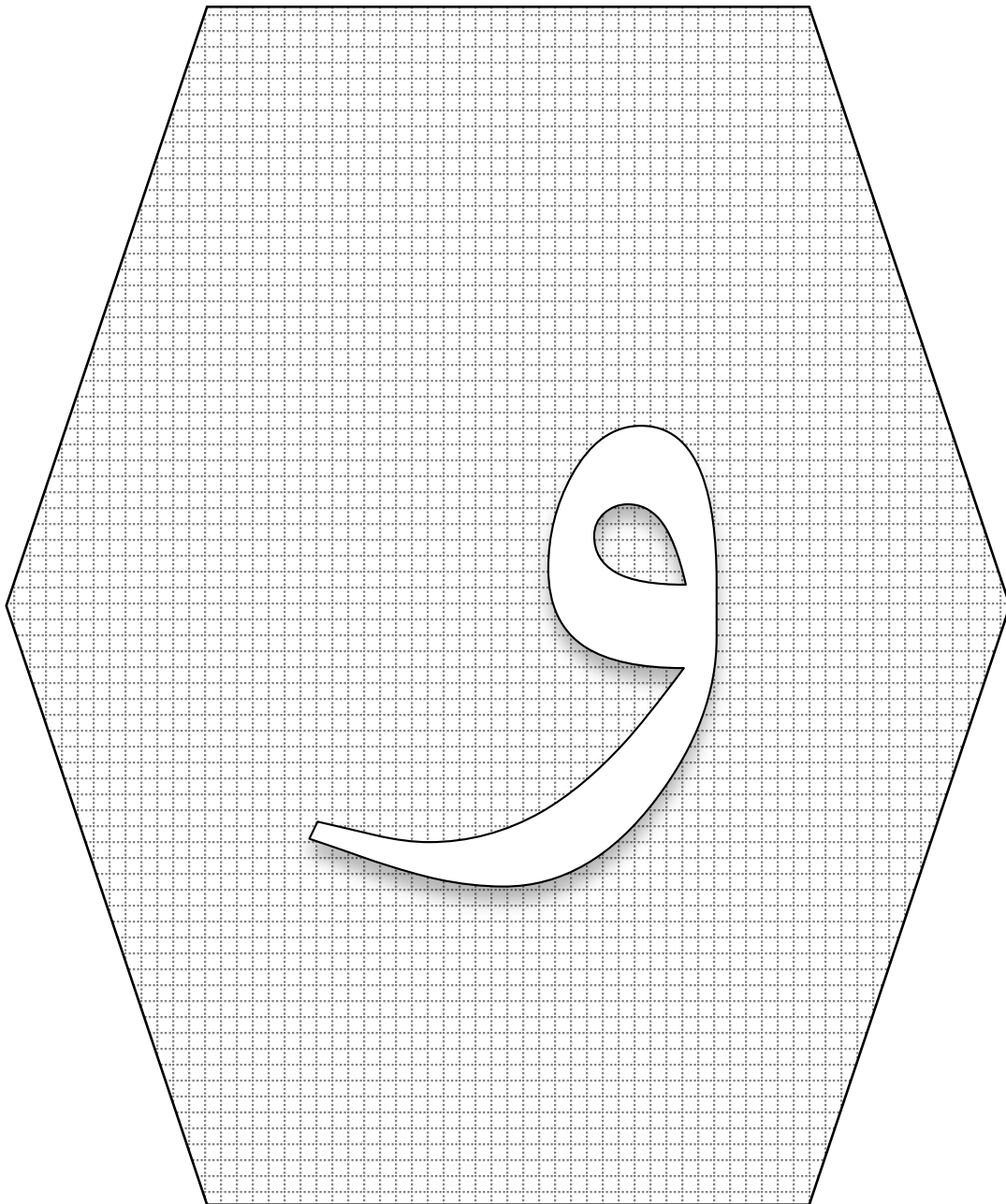



EXERCISE 105: LETTER RECOGNITION

Waw وَرْدَةٌ (wa)

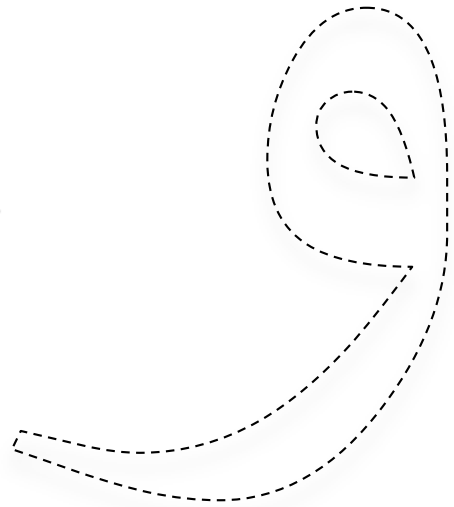
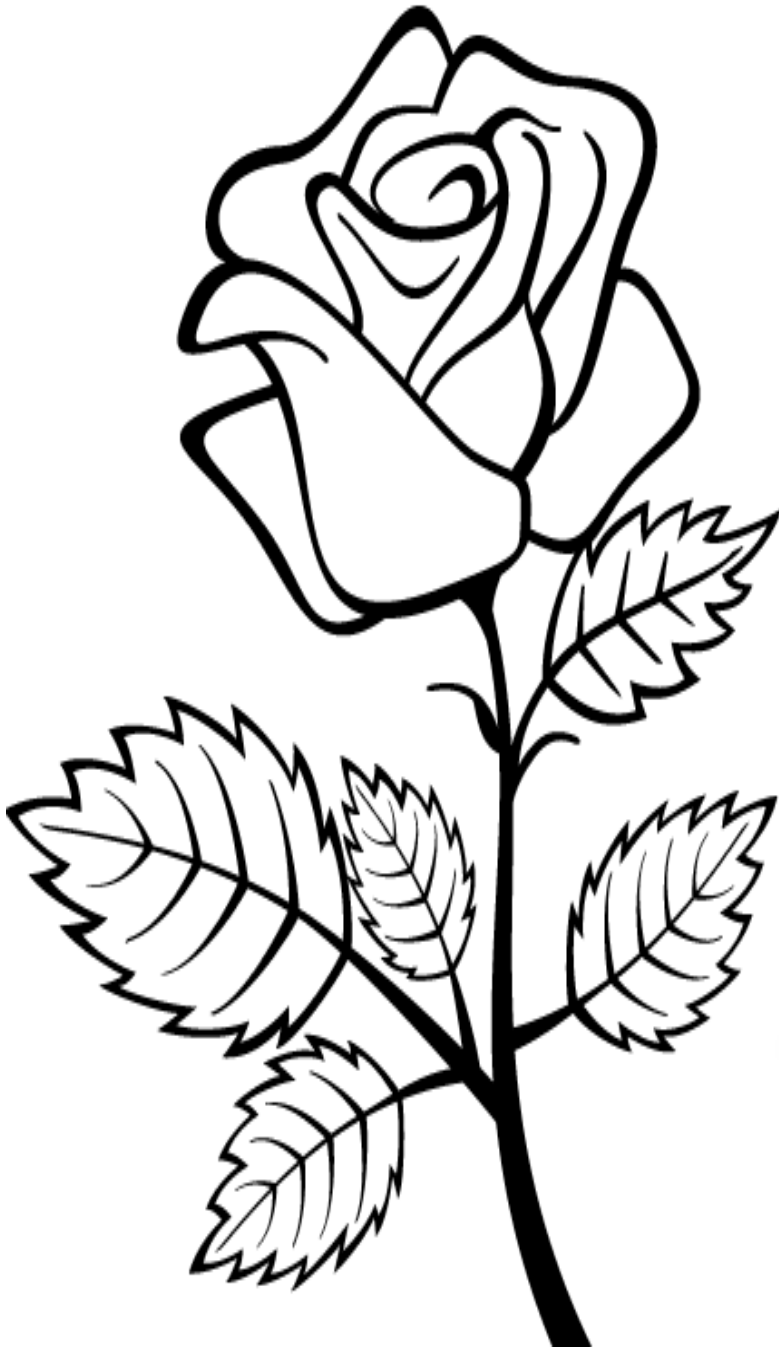

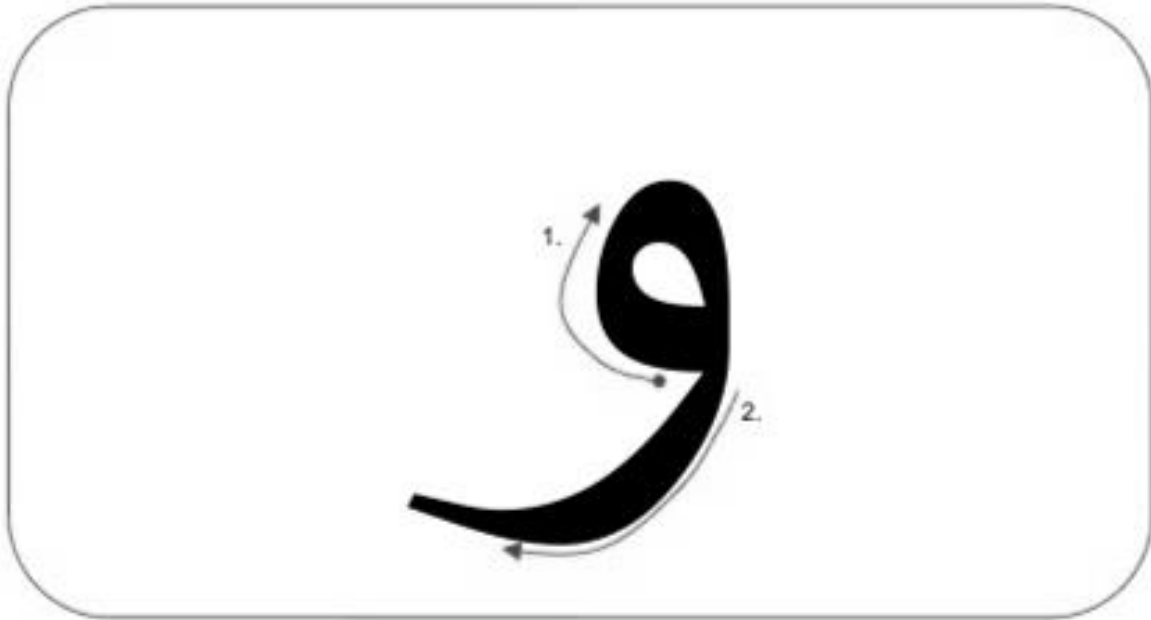

## EXERCISE 106: LETTER RECOGNITION

Join the dots and write the letter

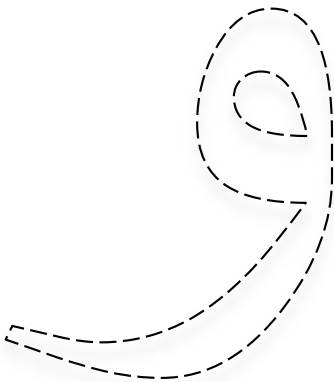
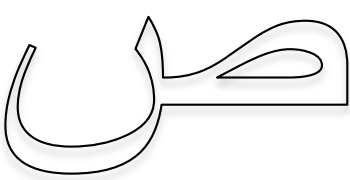

EXERCISE 107: LETTER RECOGNITIONChoose the matching letter below

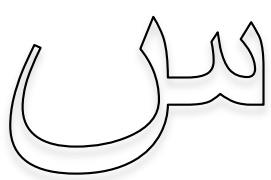
EXERCISE 108: LETTER RECOGNITION

HAI (ha)

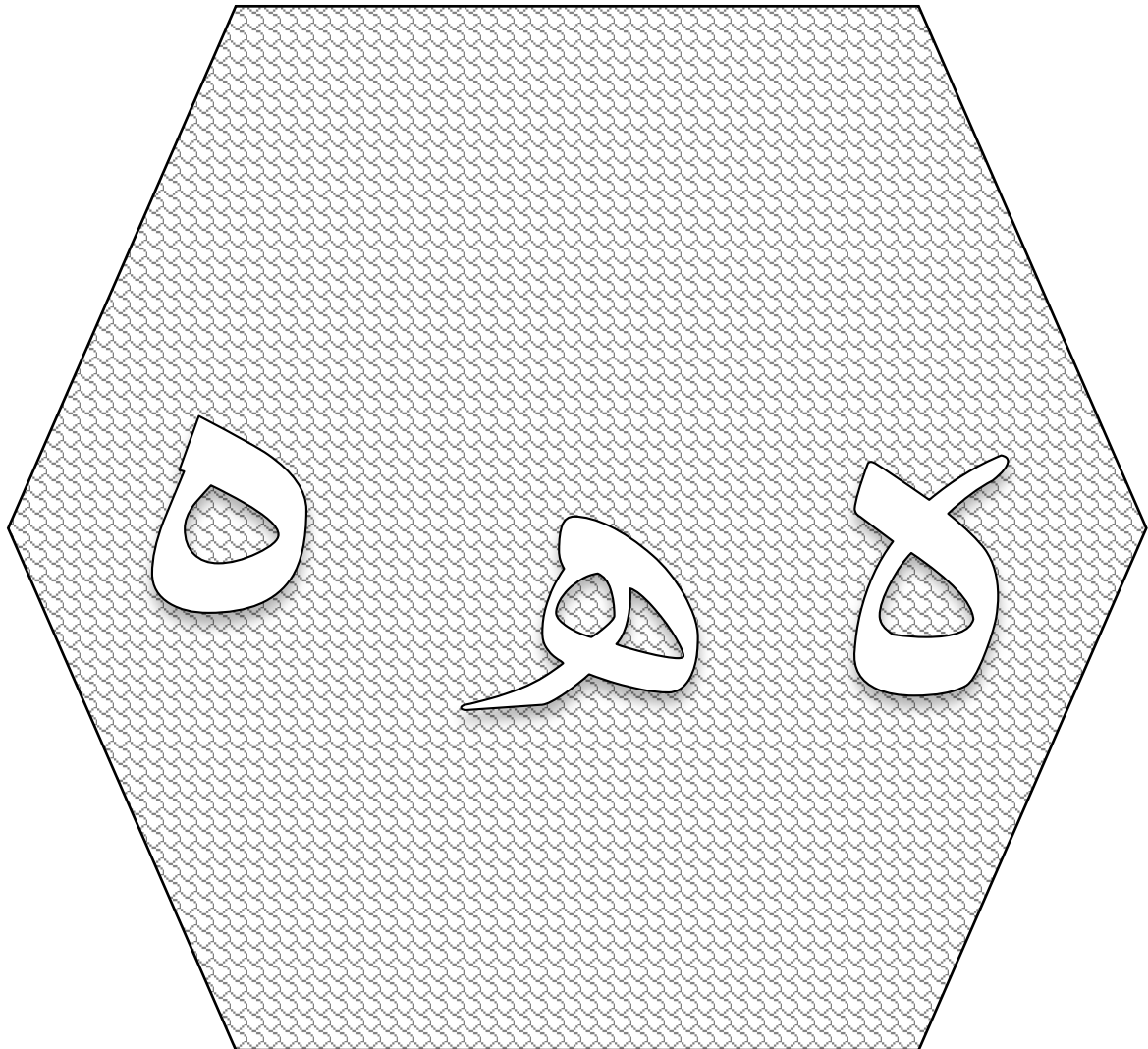

EXERCISE 109: LETTER RECOGNITION

Hai هَاتِ فَ (ha)

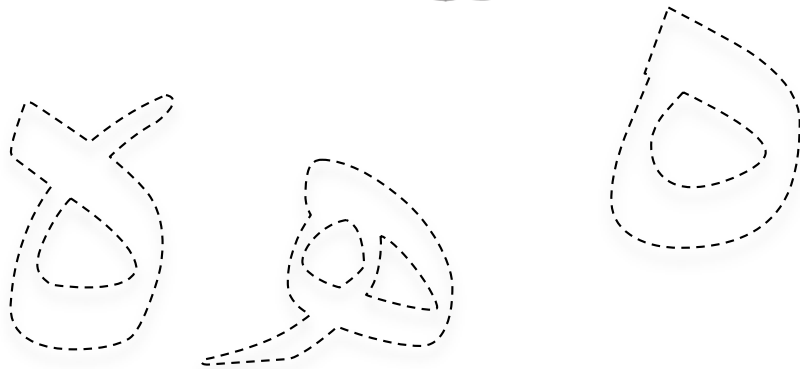
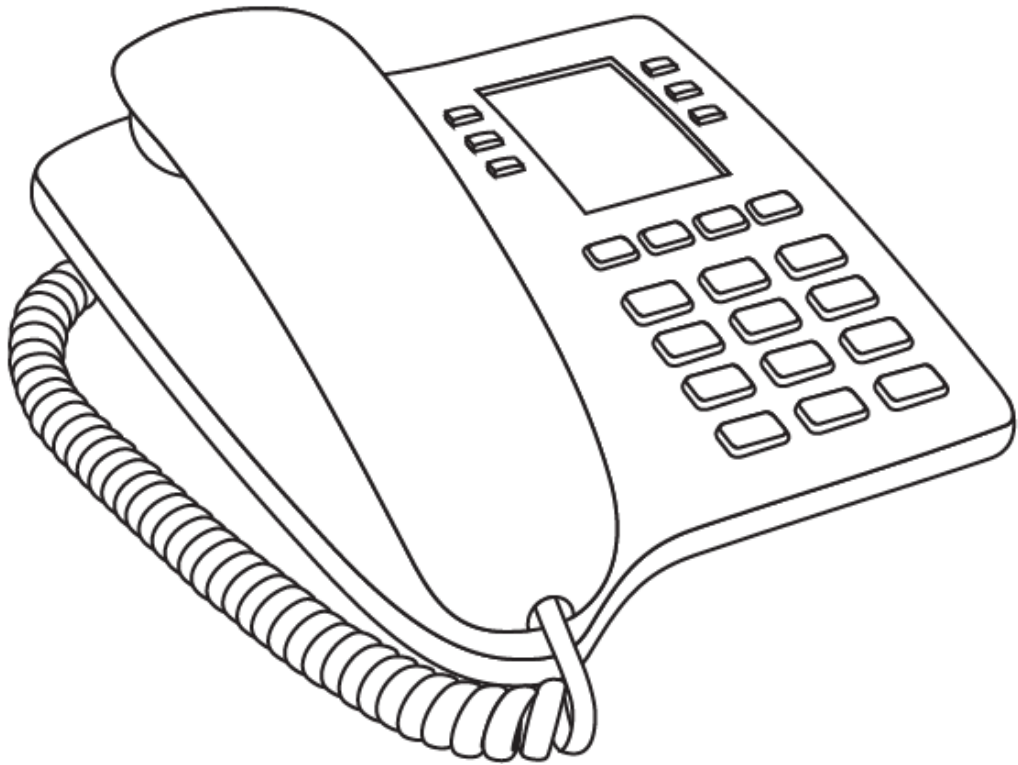



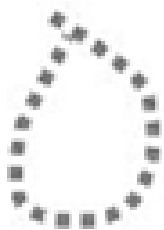
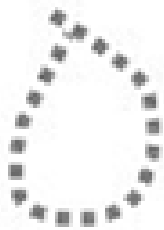
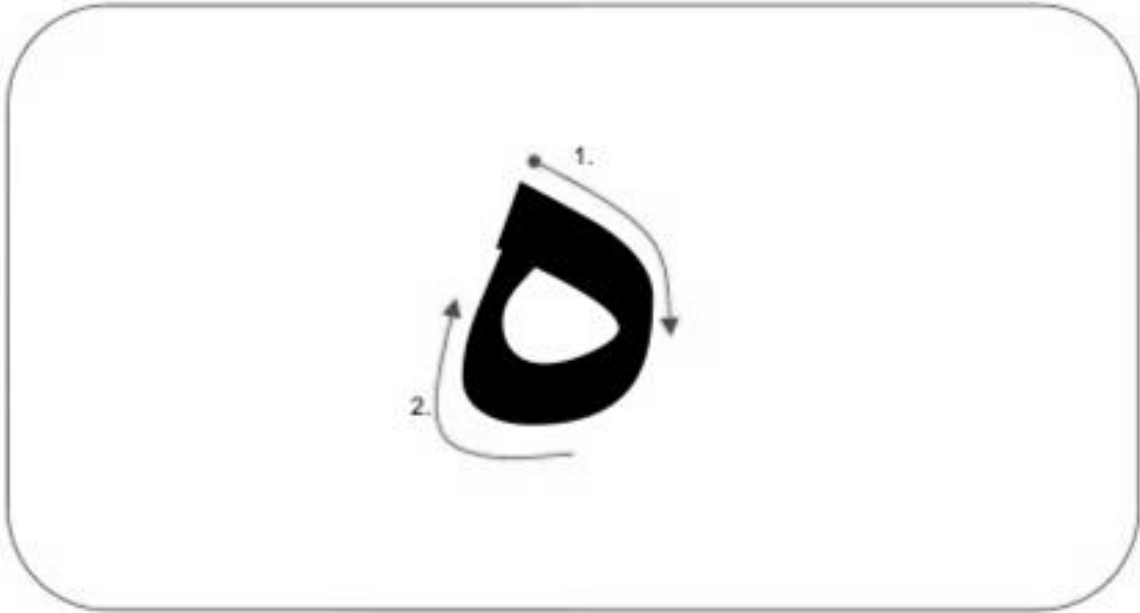

## EXERCISE 110: LETTER RECOGNITION

Join the dots and write the letter

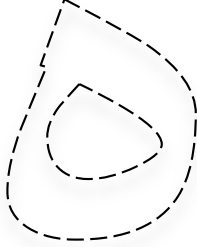

# EXERCISE 111: LETTER RECOGNITION

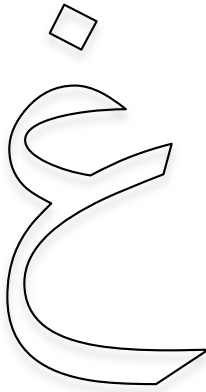
Choose the matching letter below

EXERCISE 112: LETTER RECOGNITION

YE

(ya)



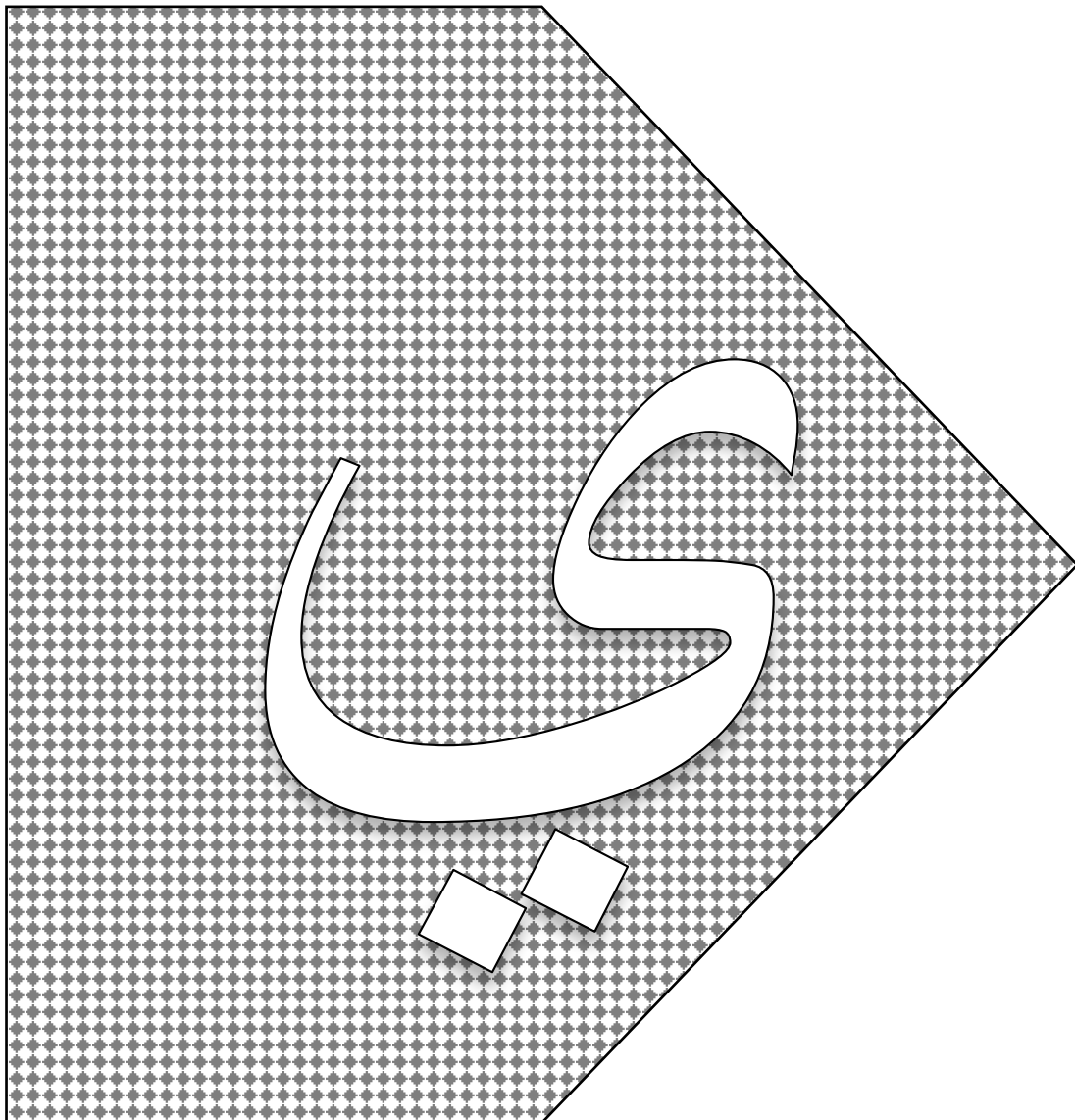

EXERCISE 113: LETTER RECOGNITION

Ye يَ مَا مَ هَ (ya)

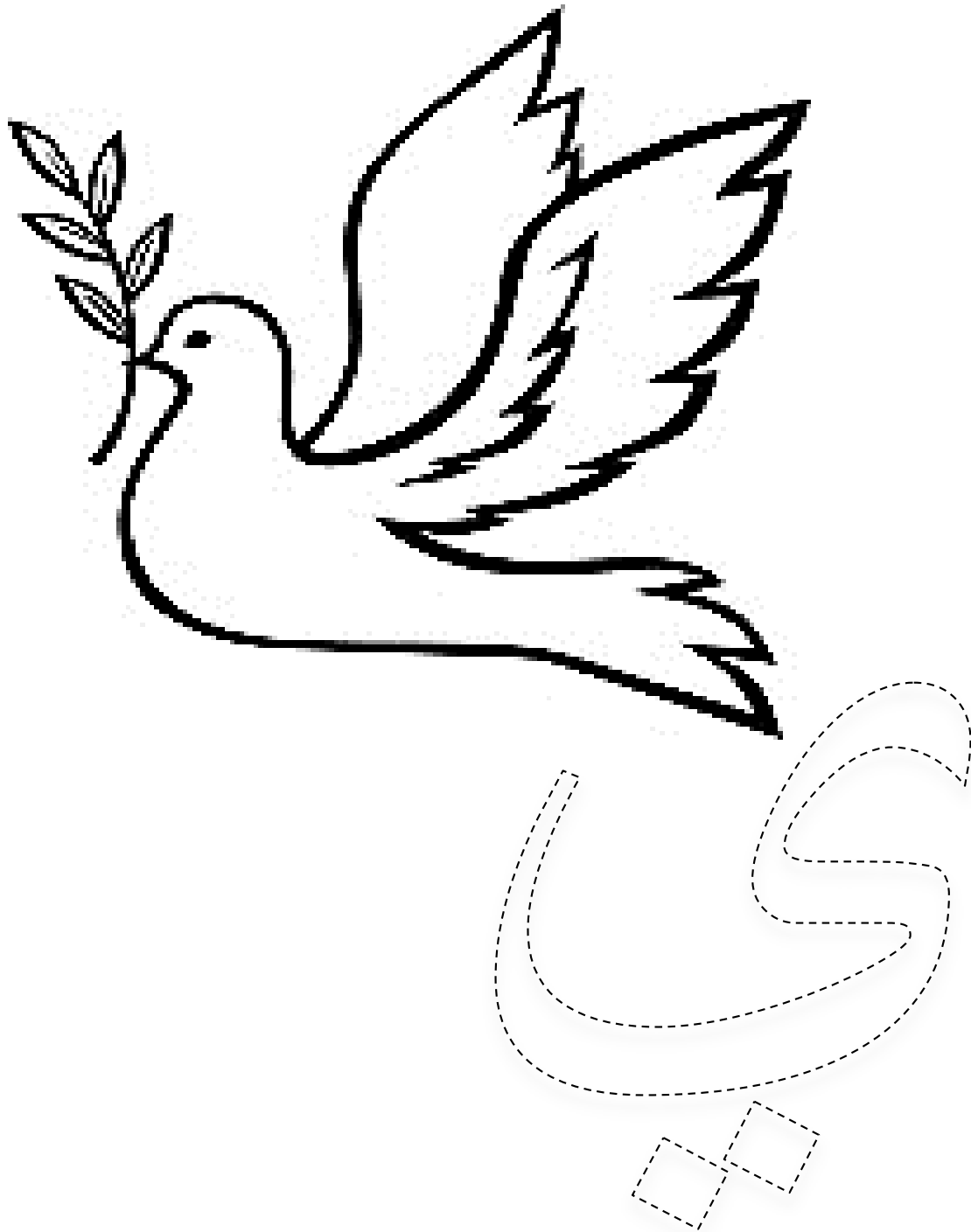

**EXERCISE 114: LETTER RECOGNITION**

**Join the dots and write the letter**

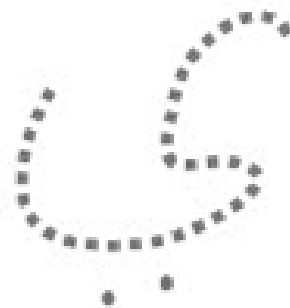
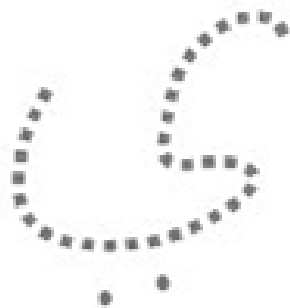
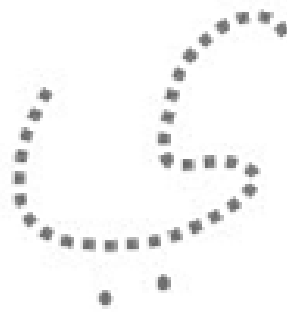
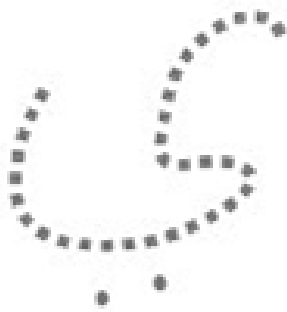
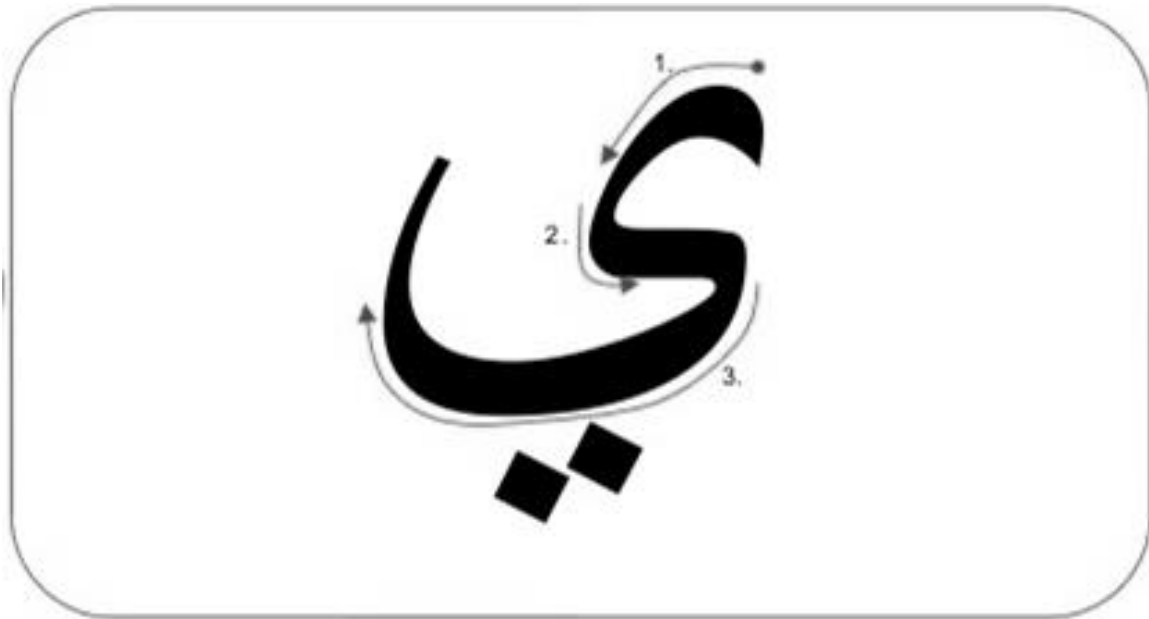



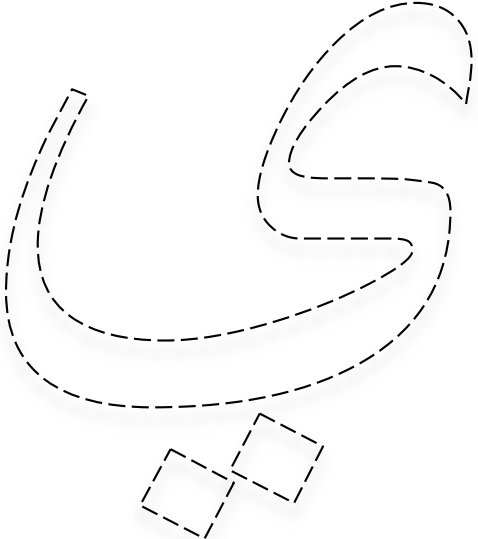
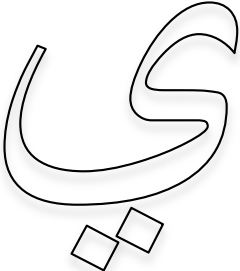
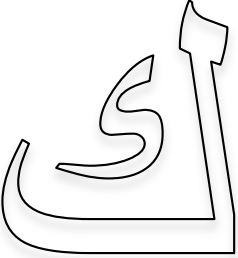
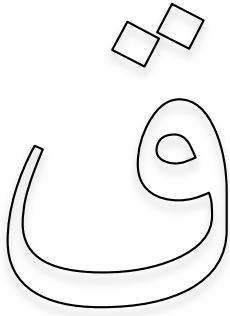

EXERCISE 115: LETTER RECOGNITIONChoose the matching letter below

EXERCISE 116: READING EXERCISE

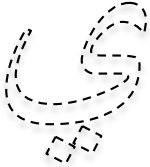
RECOGNISING LETTERS و TO ي (WAW - YE)

Read and identify the alphabets			
ي	ء	ه ه ه	و
Ye (ya)	Hamza (a)	Hai (ha)	Waw (wa)
			

EXERCISE 117: READING EXERCISE

ي ه م ء
ه و ء ي ل
ء ي ه و نغ

EXERCISE 118: LETTER RECOGNITIONCircle the correct matching letter as shown

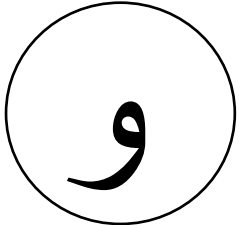
	ذ	ك	=	و
ر	و	ه	=	ه
د	ه	ع	=	ع
ق	ي	ه	=	ي

EXERCISE 119: CONNECT THE MATCHING LETTERS

ر

و

و

ه

ي

ر

ه

ي

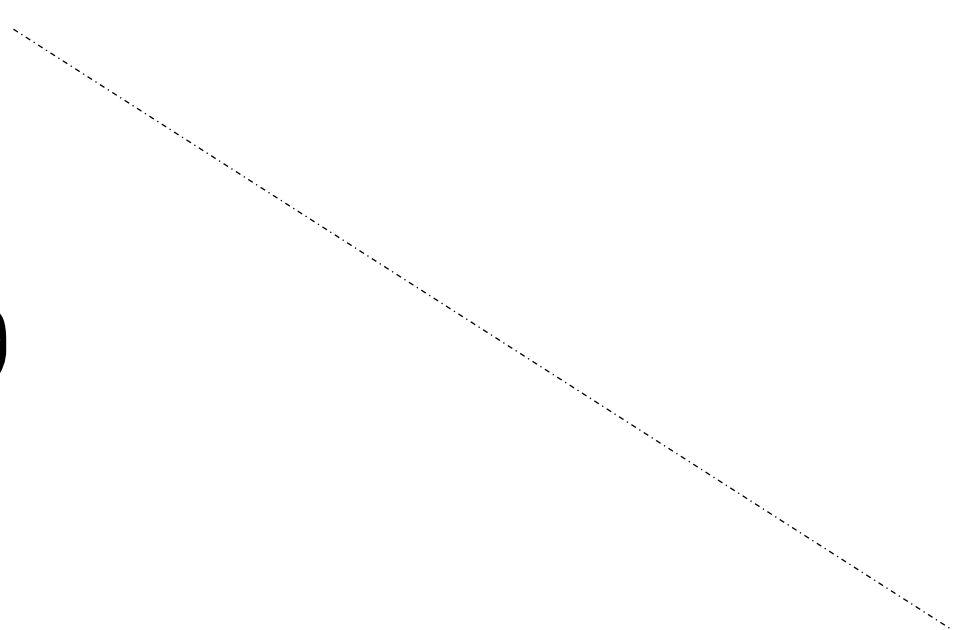

EXERCISE 120: JOINING EXERCISERECOGNISING LETTERS ن TO ي (NUN - YE)

Help the mouse get the cheese with the matching letter

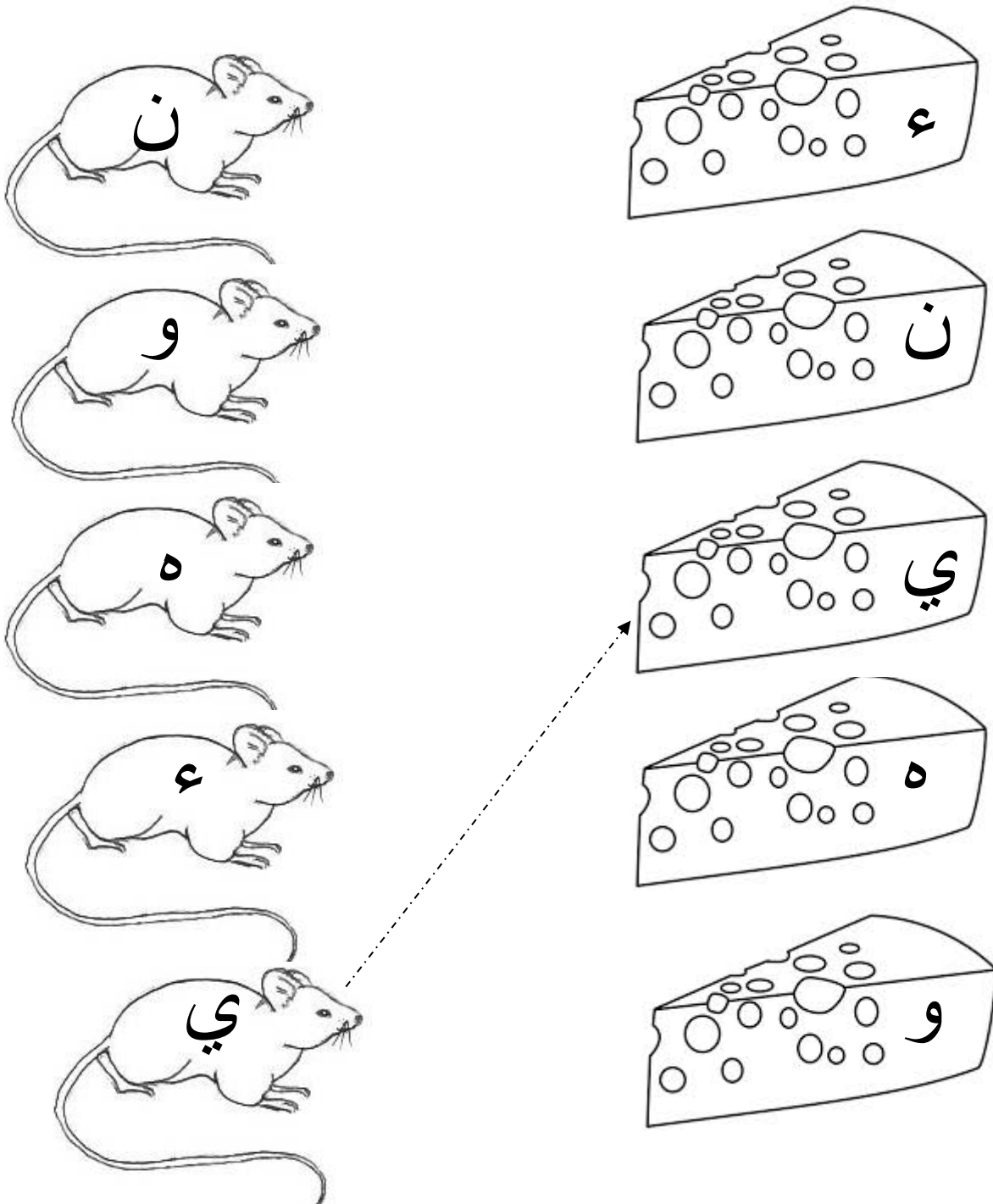

EXERCISE 121: JOINING EXERCISERECOGNISING LETTERS ن TO ي (NUN - YE)

Lead the bees to the correct letter in the hive

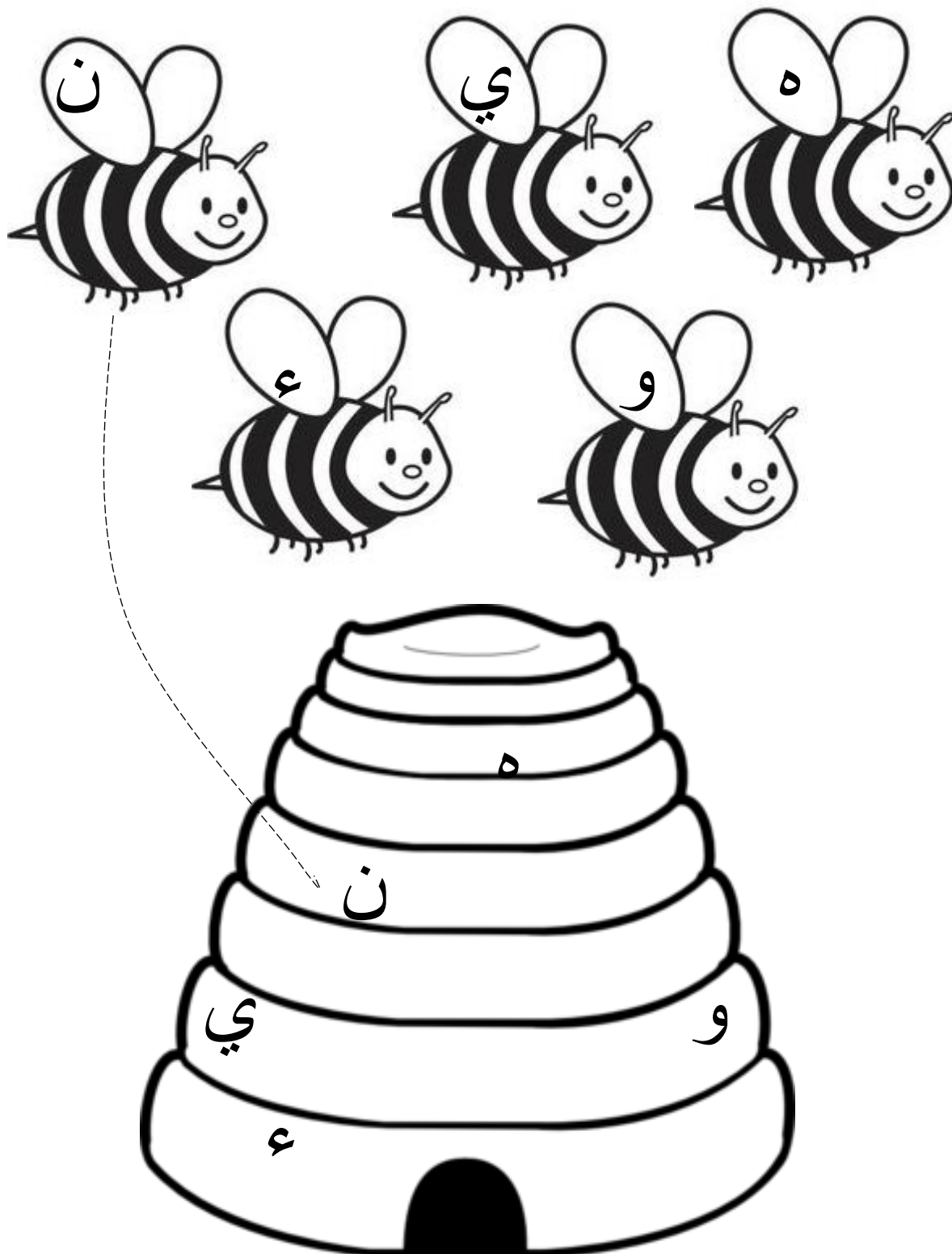





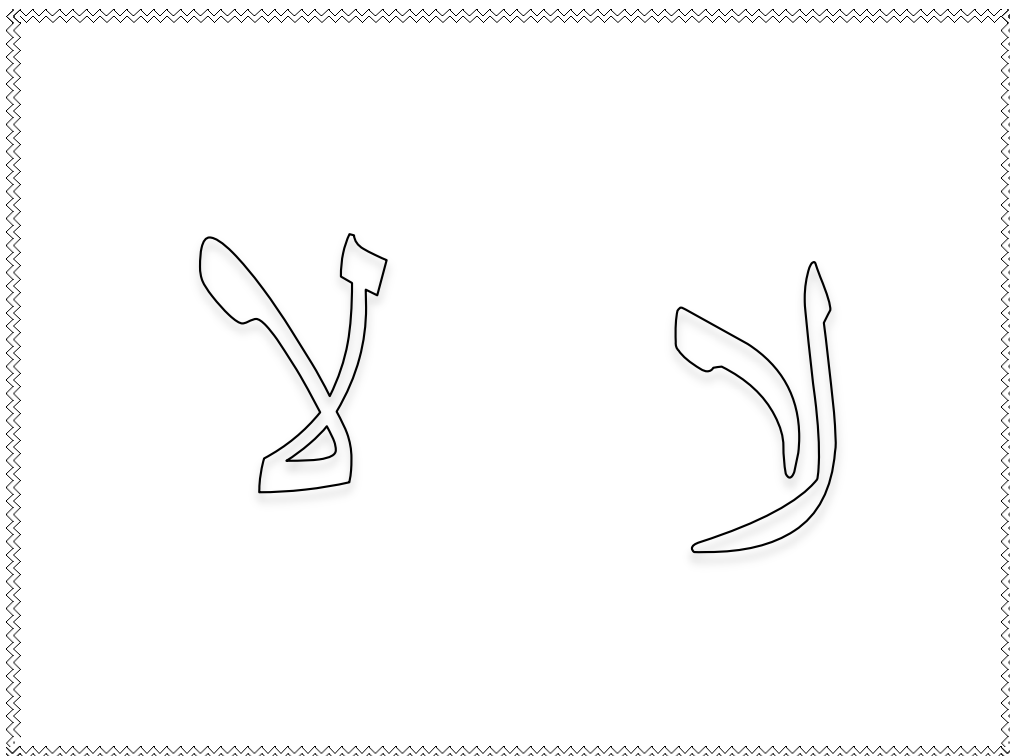
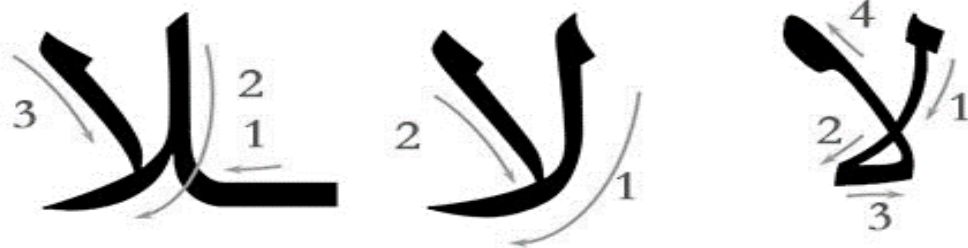

EXERCISE 122: LETTER RECOGNITIONLAM ALIF = ALIF + LAM

لا = ا + ل

لا = ا + ل

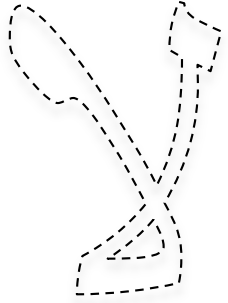
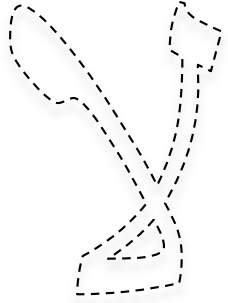
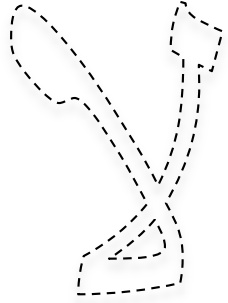

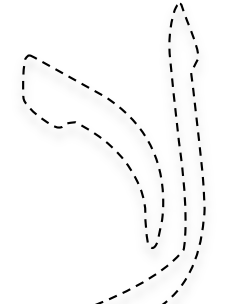
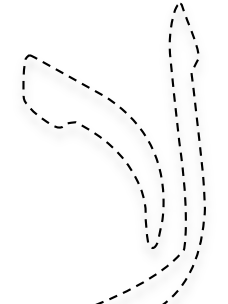
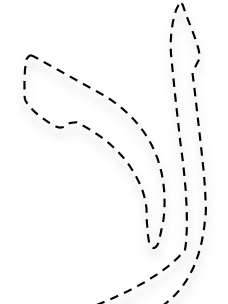











**EXERCISE 123: LETTER RECOGNITION**  
**OVERWRITE WITH A PENCIL**

**EXERCISE 124: WRITING EXERCISE**

Join the dots and write the letter

<p>YE (ya)</p>	<p>HAI (ha-heavy)</p>	<p>WAW (wa)</p>
		
		
		
		

## WHAT WE HAVE LEARNT IN CLASS ONE

### THE HURUFUL HIJAI (THE ARABIC ALPHABET)

All the sounds covered so far have been put together into the next exercises. Make sure all the sounds are pronounced correctly. Repeat these exercises as many times as necessary to improve understanding, fluency, makharij and confidence of the student.

**Teacher/ Parent Note:** Exercise 124 brings us to the end of the Syllabus for Class One. Try the Exercises 125 - 146 below and test the student and see if they have grasped all that has been taught so far. Congratulate the student on this big achievement and encourage them to aim higher.

Please ensure that the child is completely sure and can recognize all the letters, before proceeding to the next level.

EXERCISE 125: READING ALPHABETS

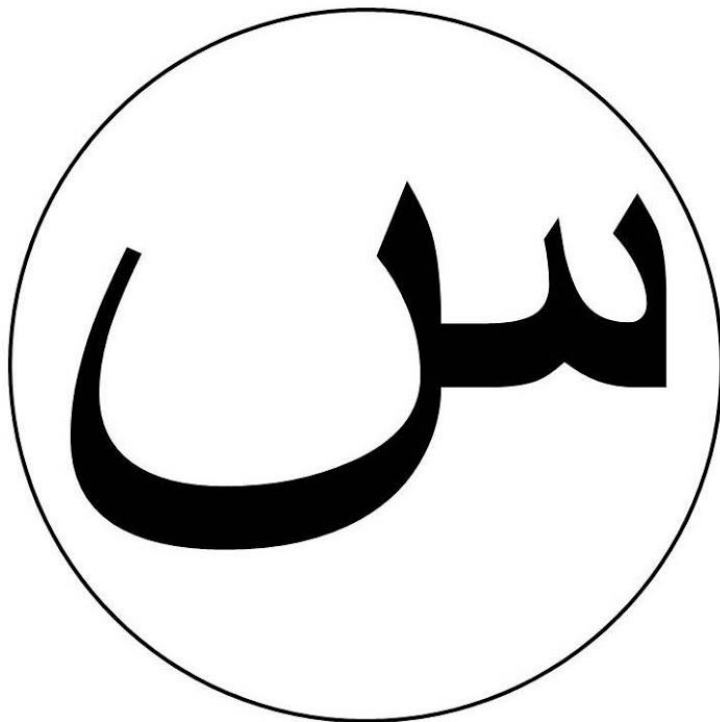
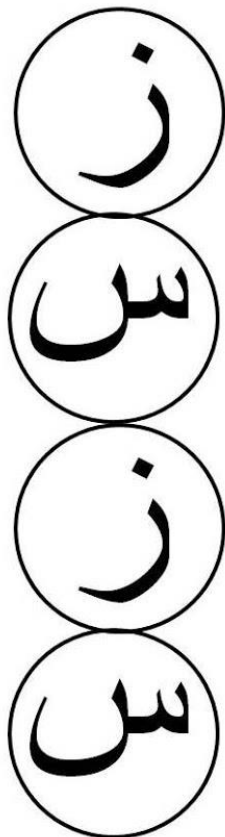
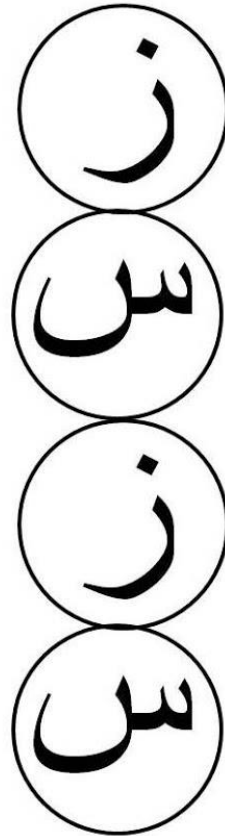
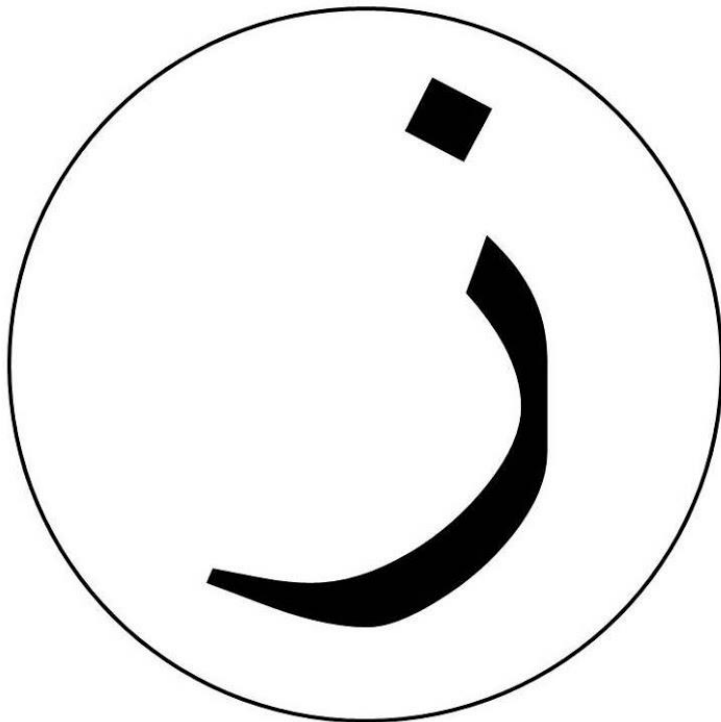

EXERCISE 126: READING ALPHABETS



EXERCISE 127: READING ALPHABETS

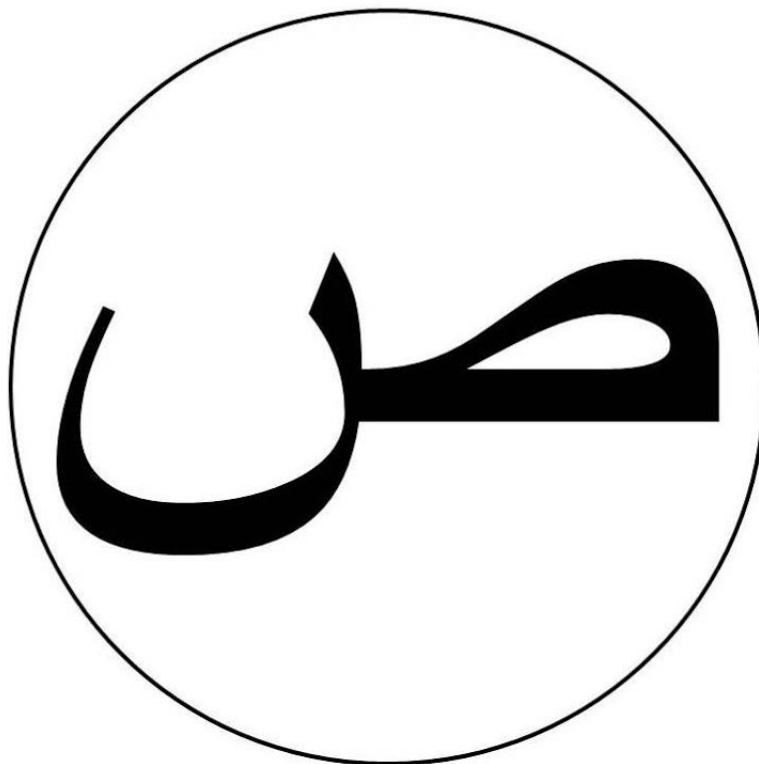
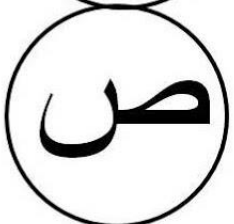
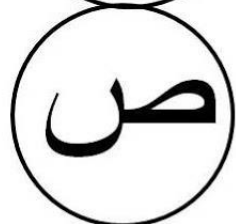

EXERCISE 128: READING ALPHABETS

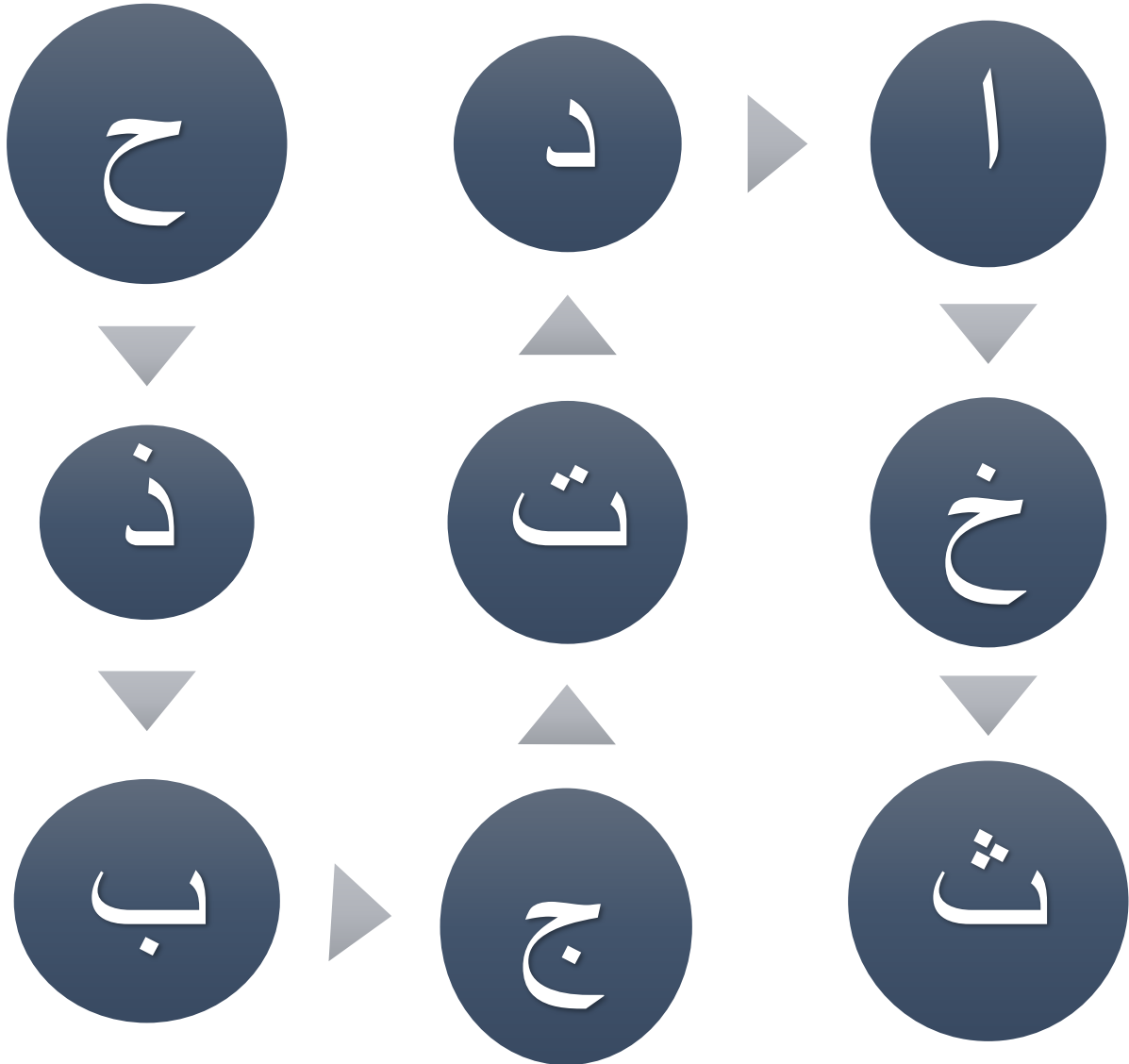



EXERCISE 129: READING ALPHABETS

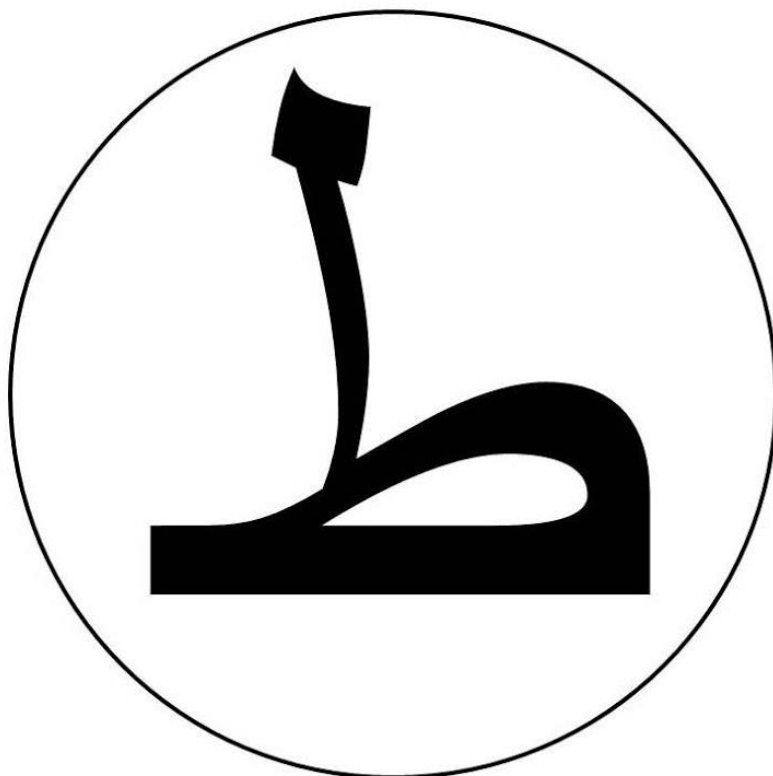
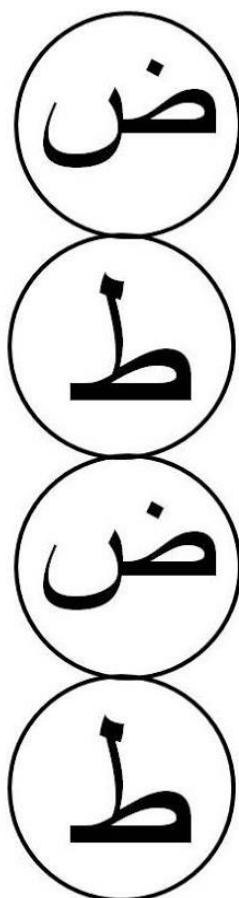
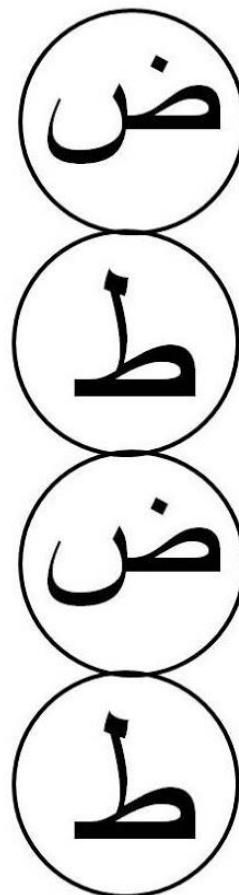

EXERCISE 130: IDENTIFY THE LETTERS

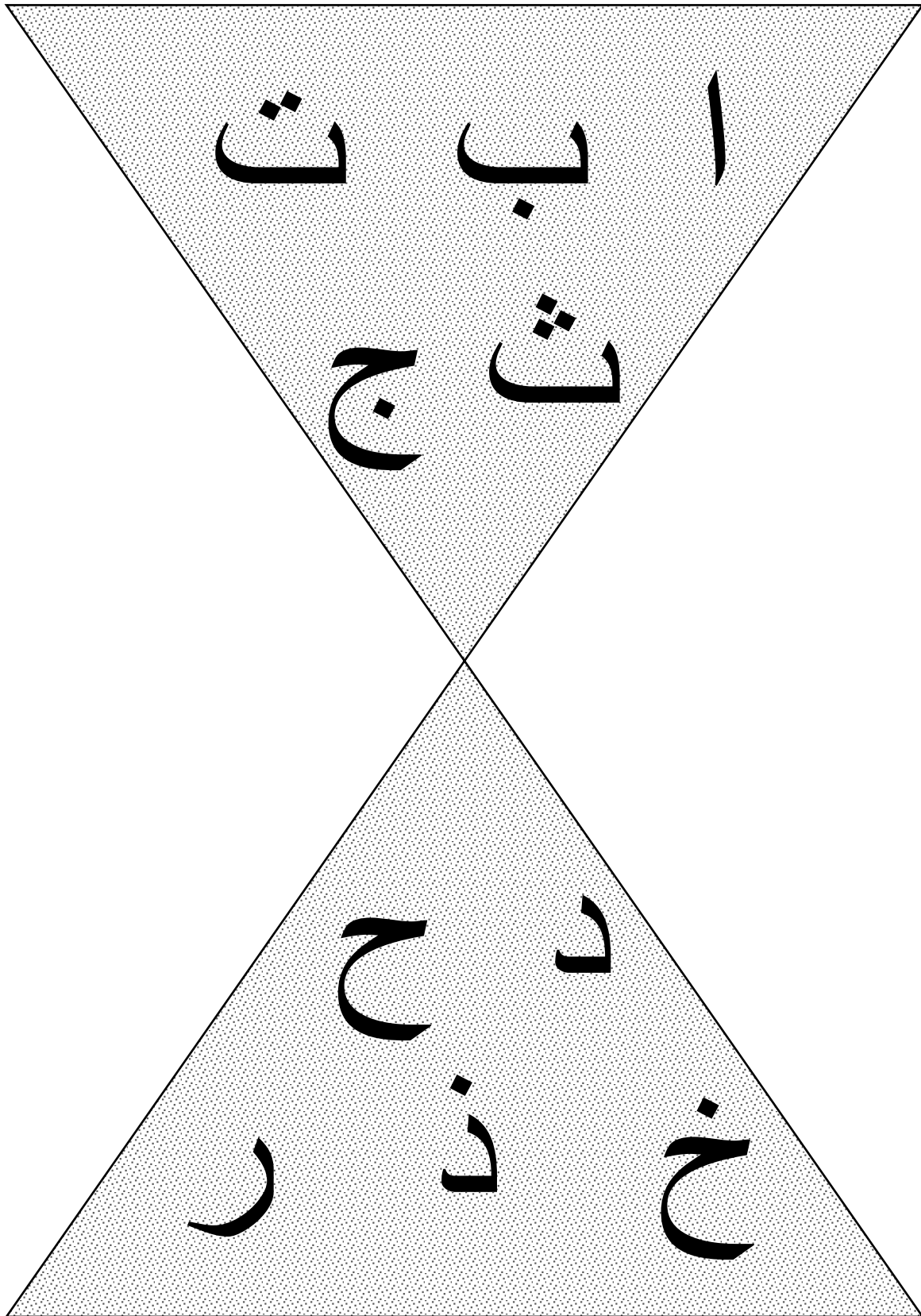

EXERCISE 131: READING ALPHABETS

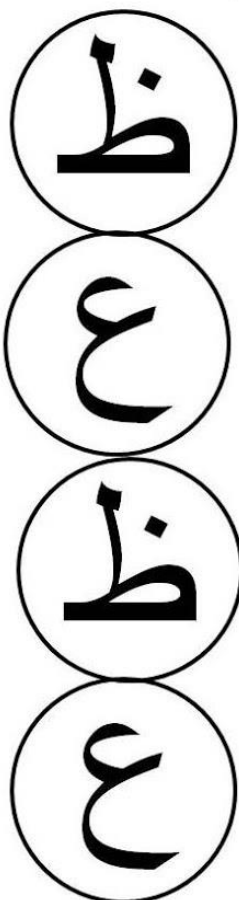
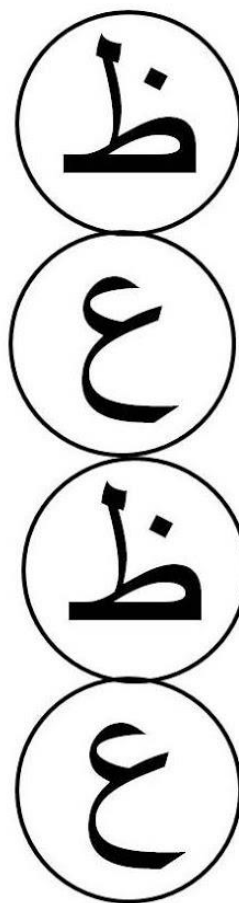
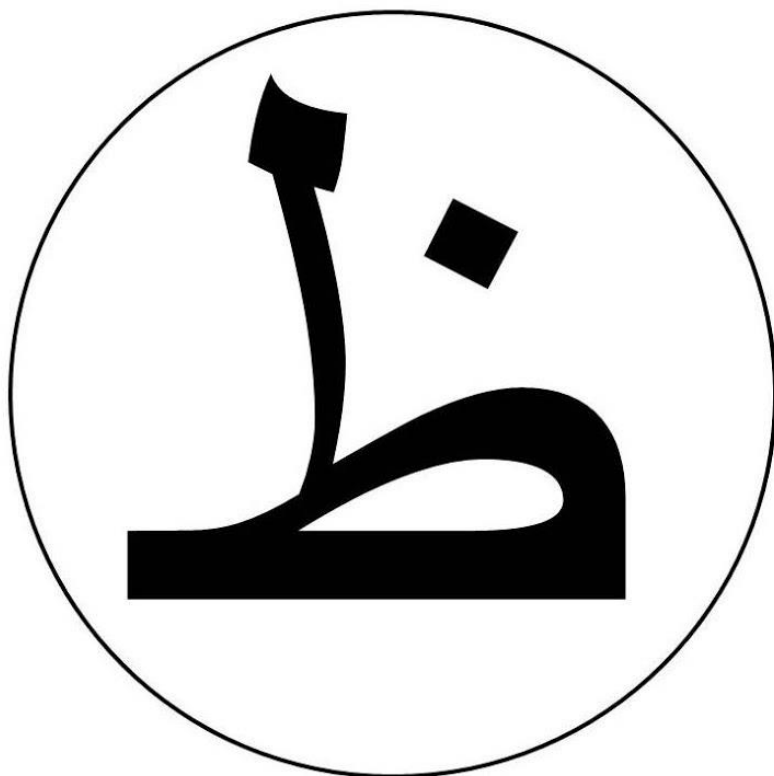

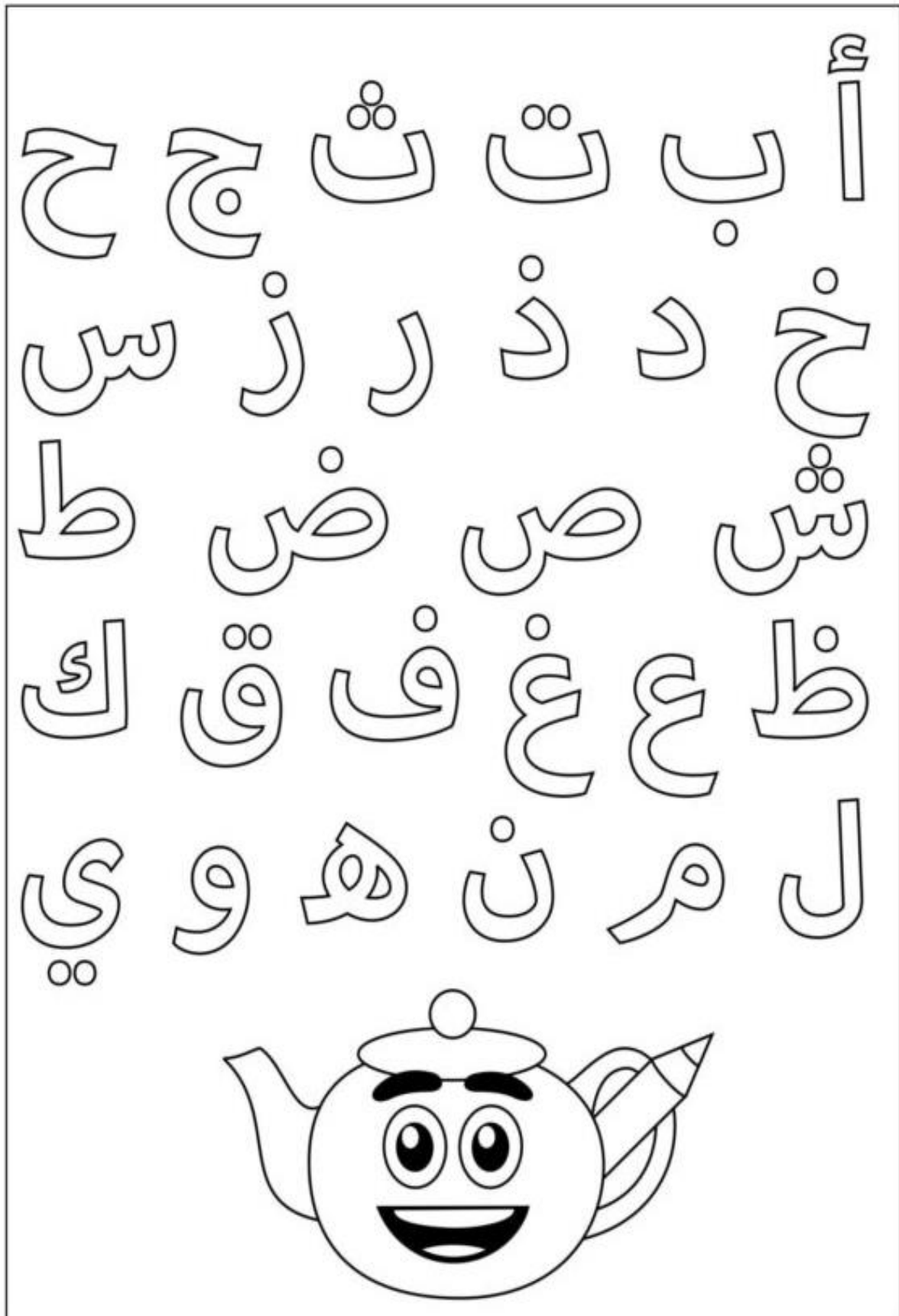
EXERCISE 132: READING ALPHABETS

EXERCISE 133: READING ALPHABETS

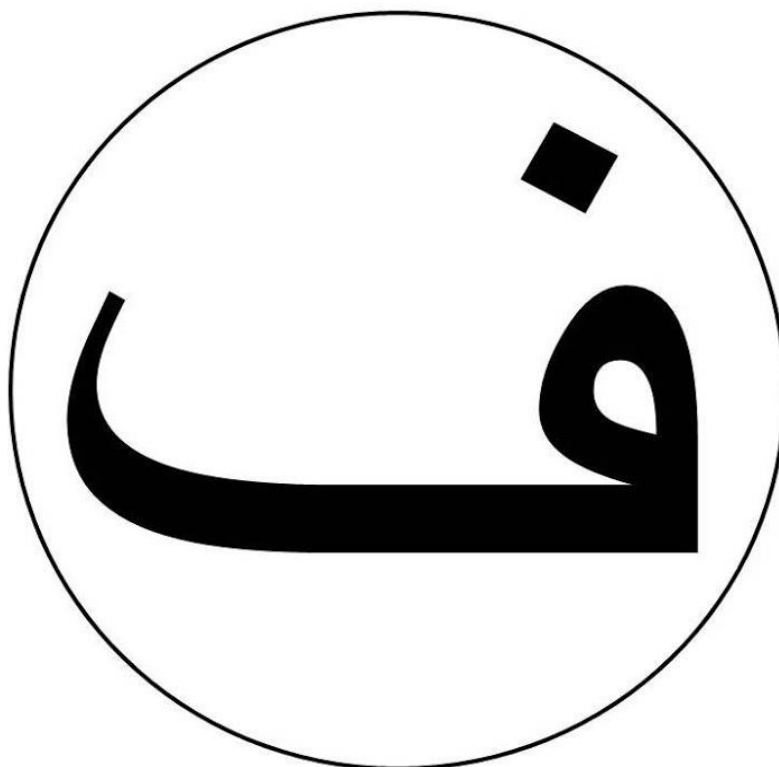
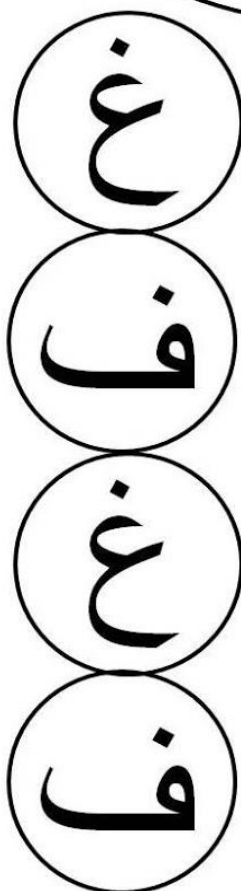
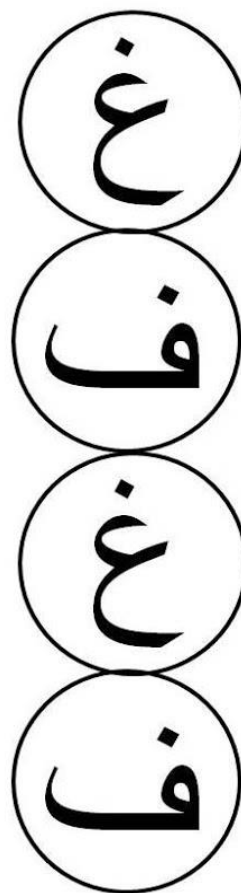
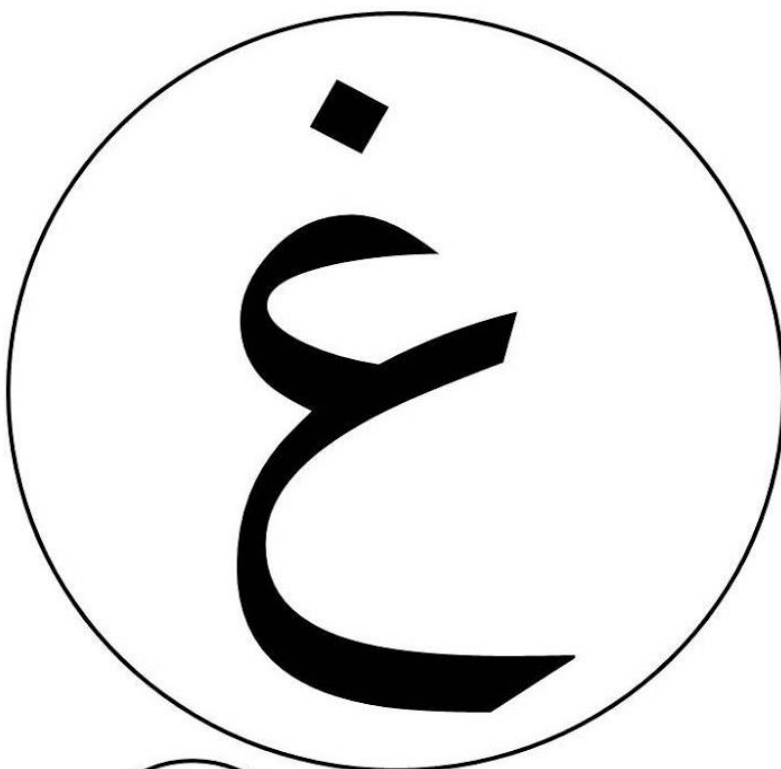

EXERCISE 134: READING ALPHABETS

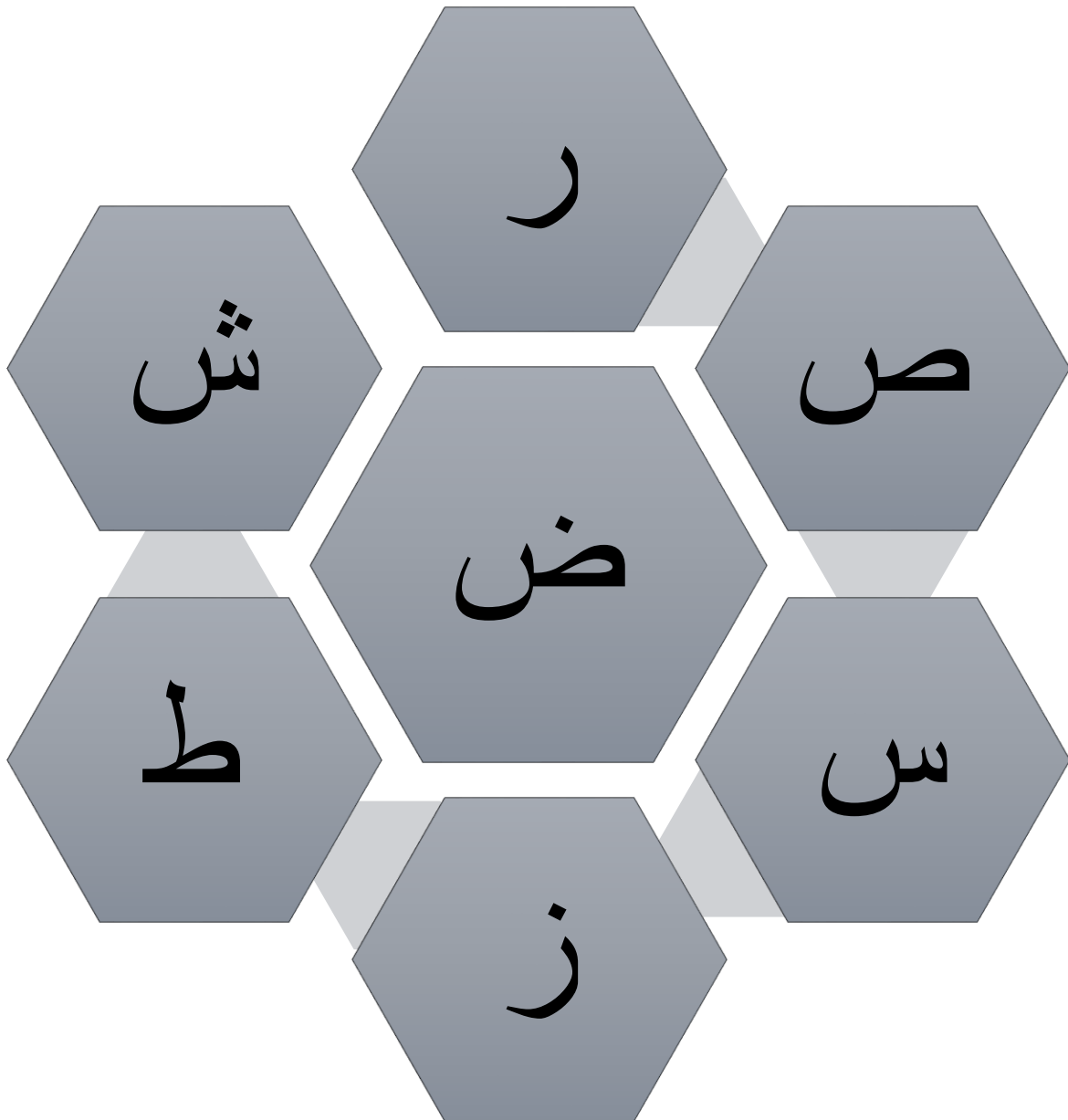

EXERCISE 135: READING ALPHABETS

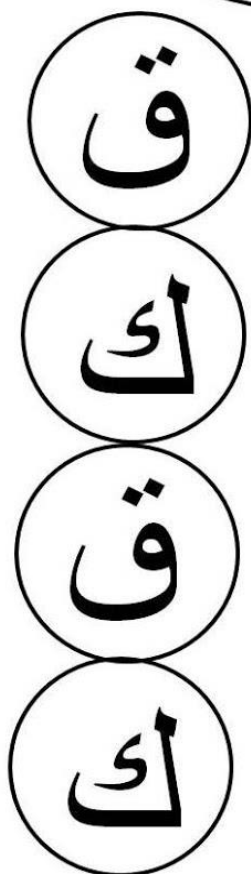
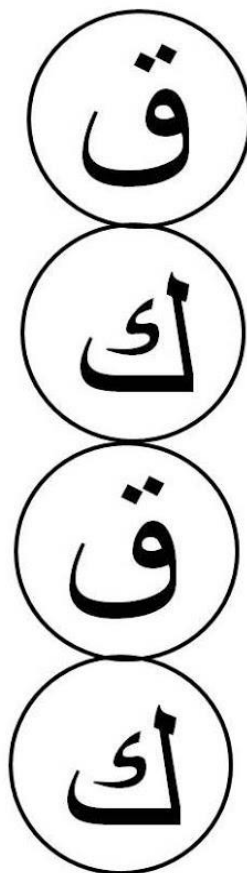

EXERCISE 136: IDENTIFY THE LETTERS

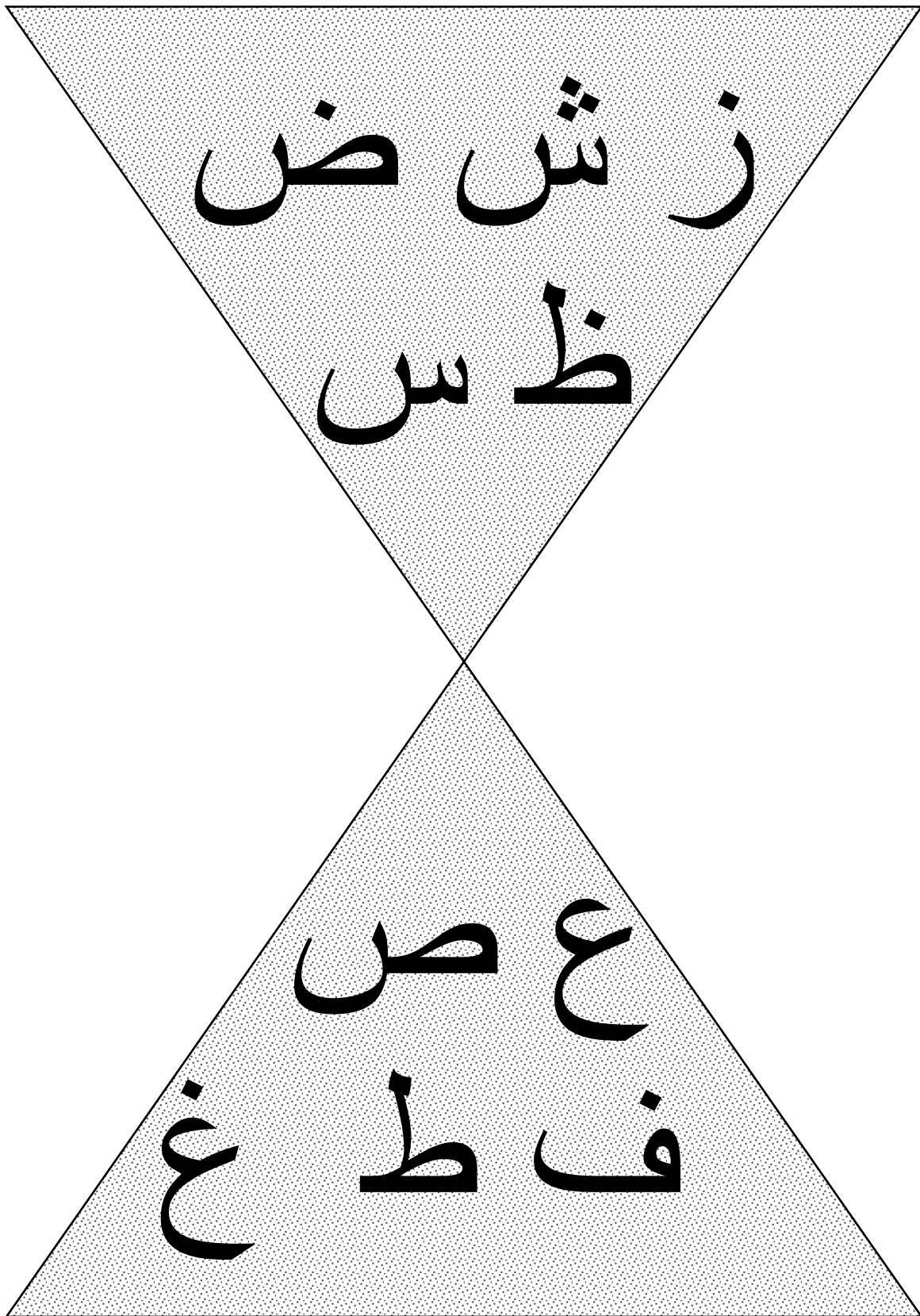



EXERCISE 137: READING ALPHABETS

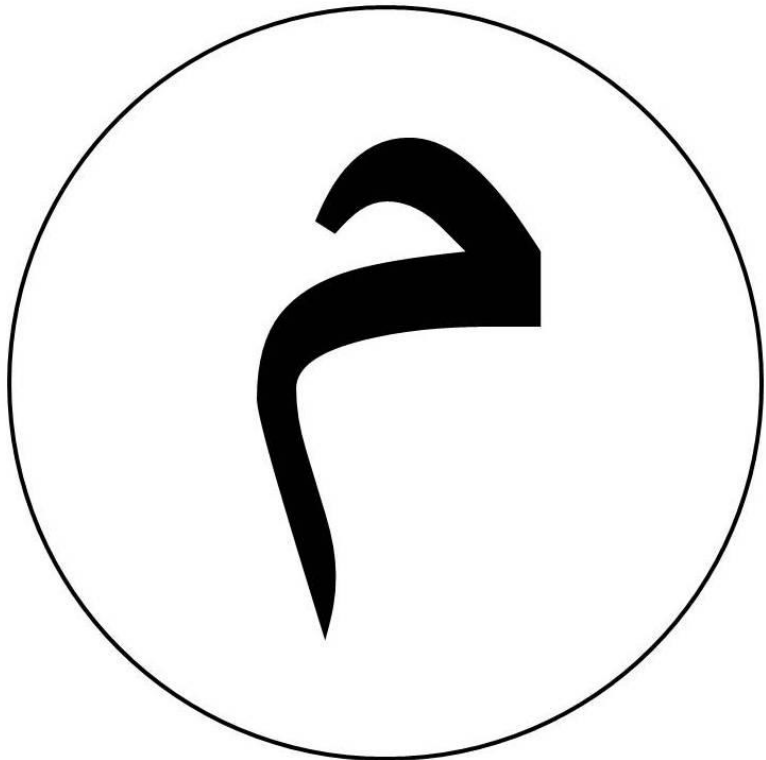
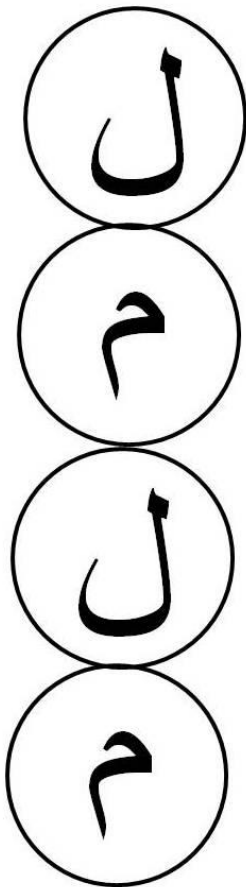
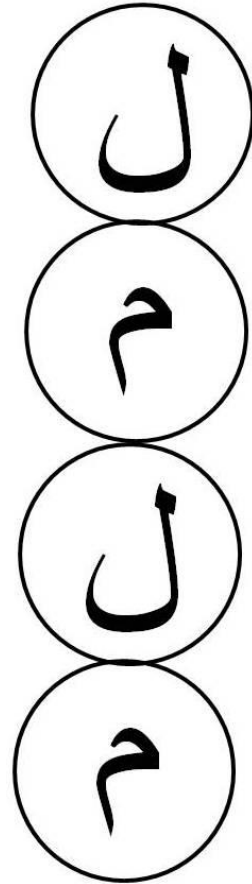
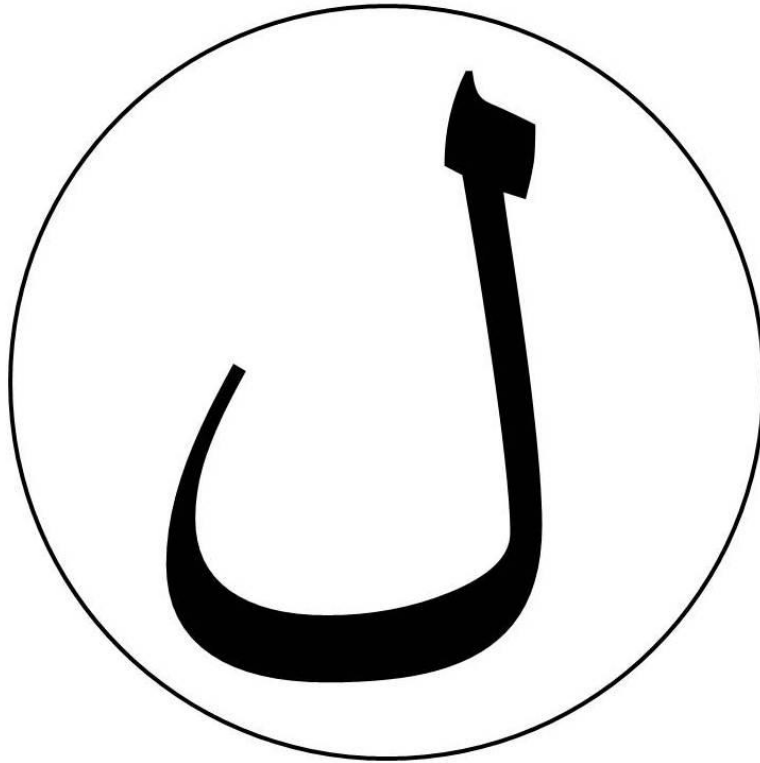

EXERCISE 138: READING ALPHABETS



EXERCISE 139: READING ALPHABETS

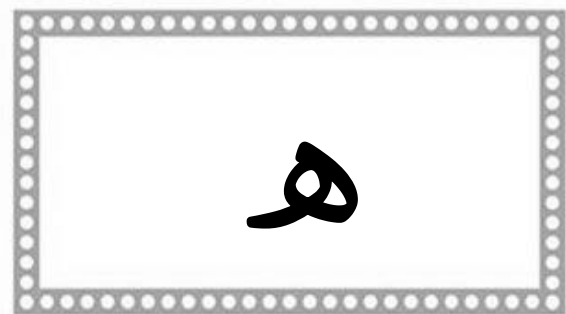
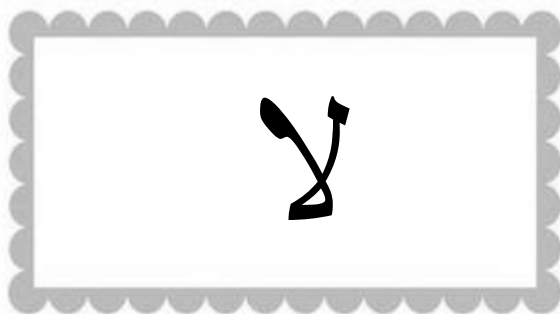
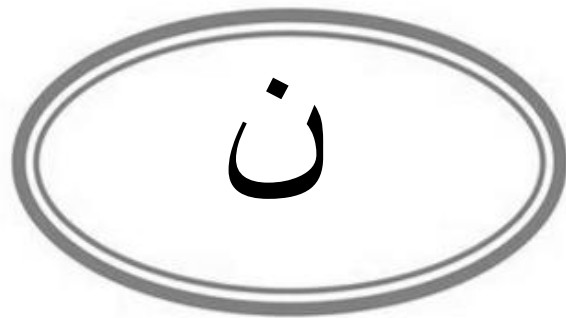
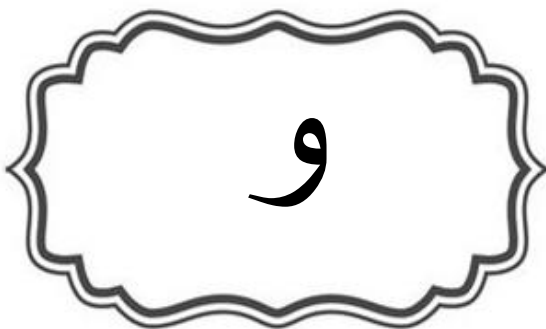
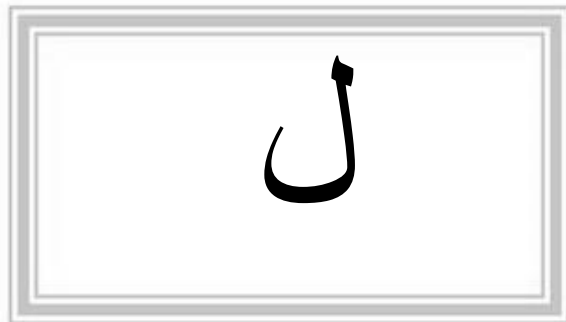
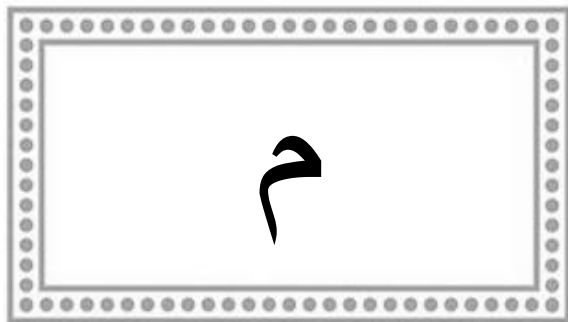

EXERCISE 140: READING ALPHABETS

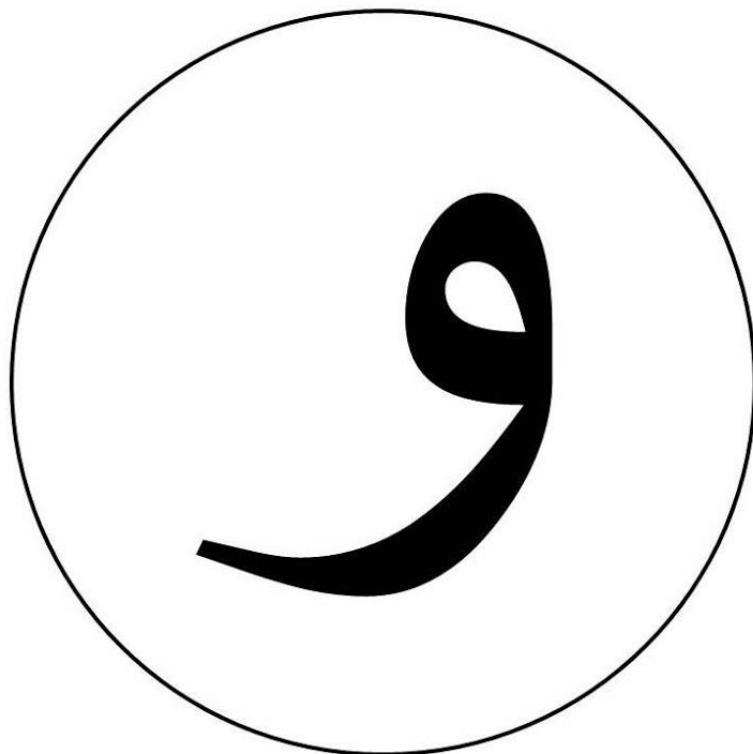
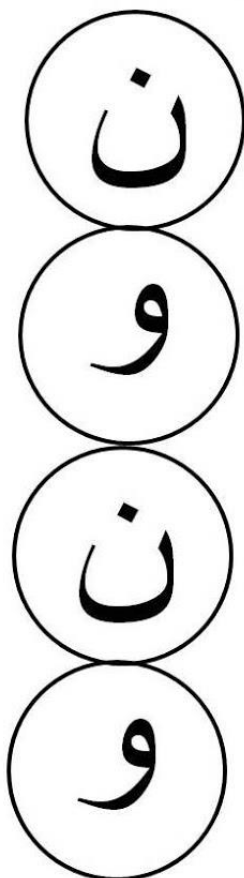
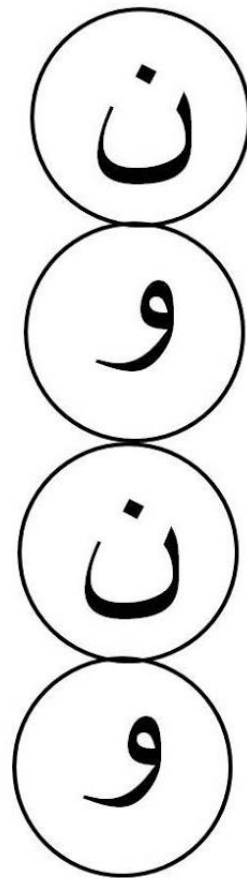
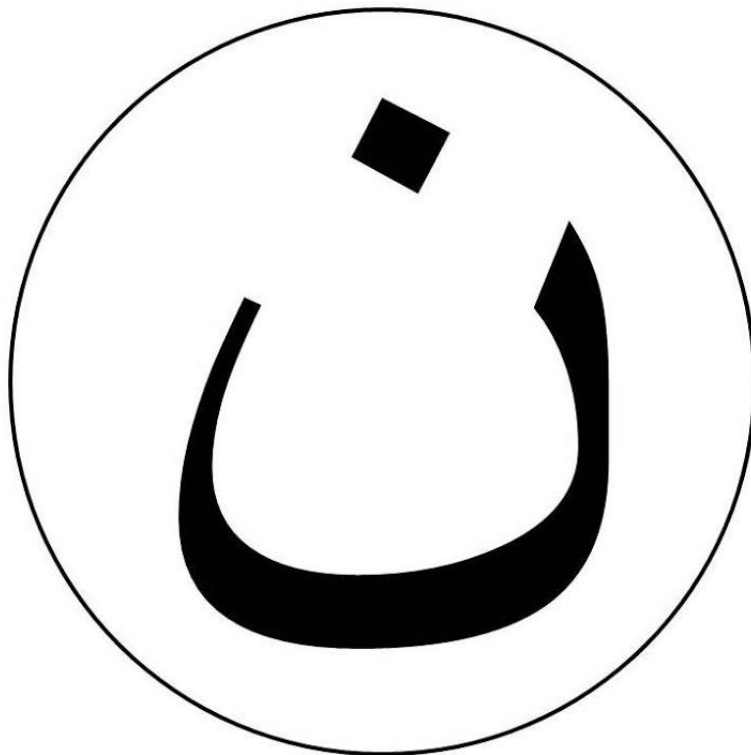

EXERCISE 141: READING ALPHABETS

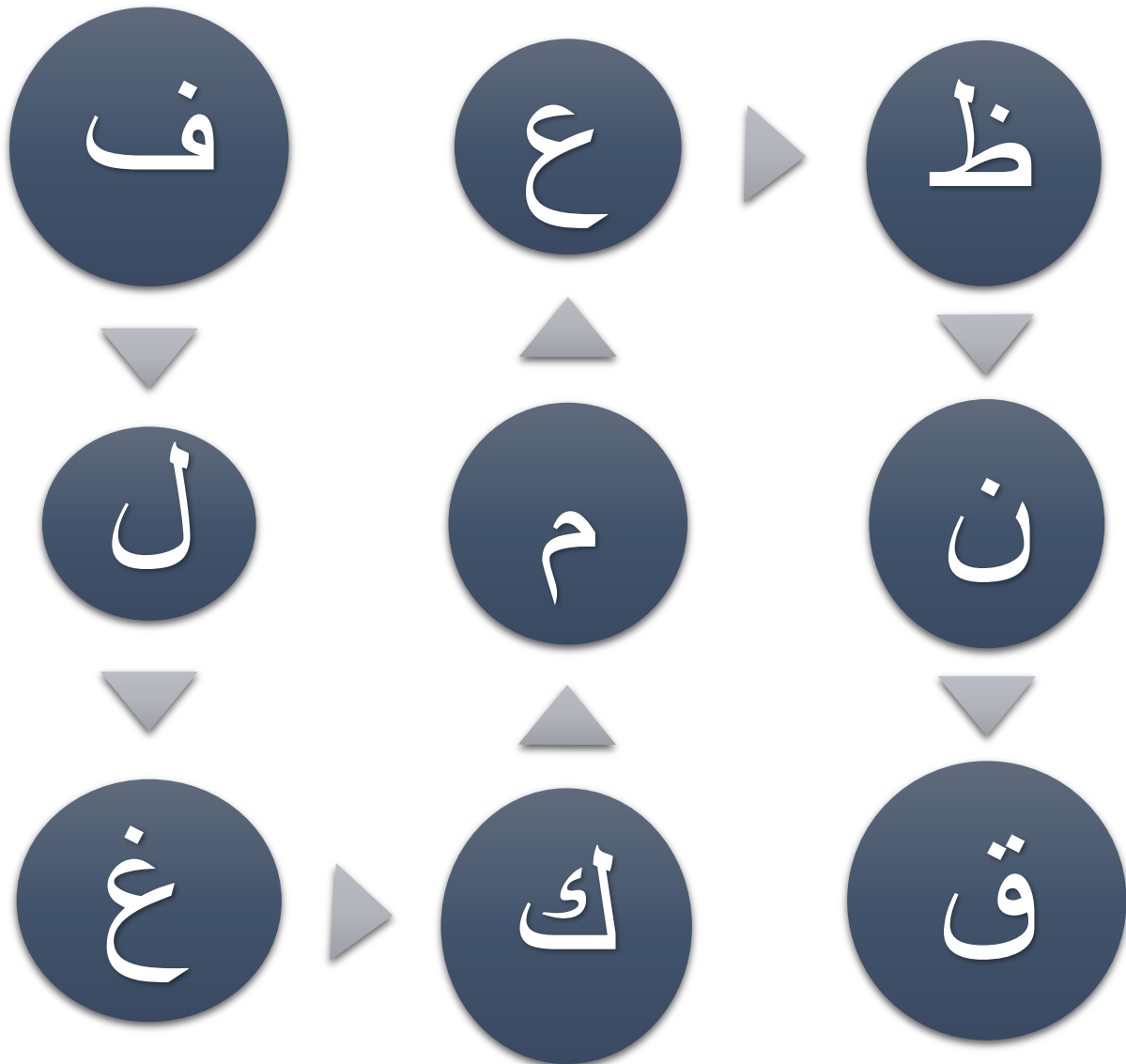

EXERCISE 142: READING ALPHABETS

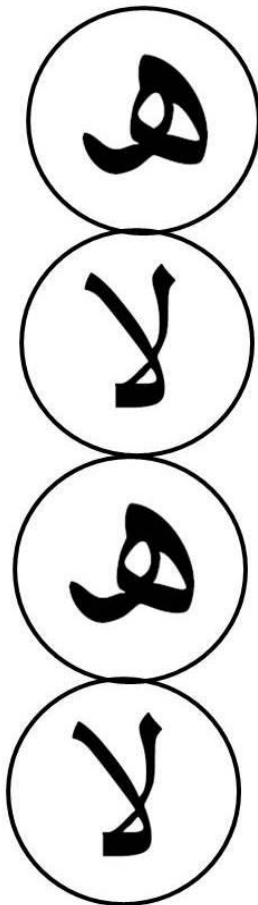
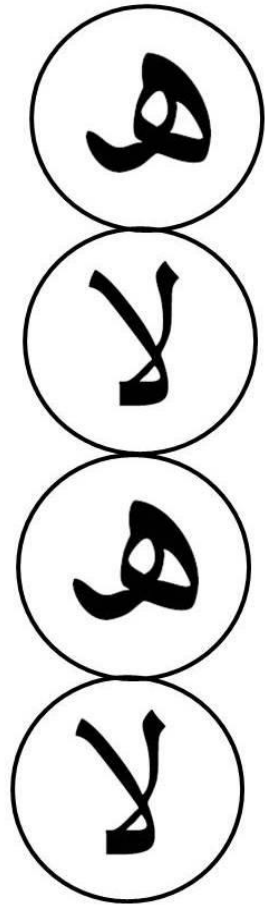

## EXERCISE 143: LETTER RECOGNITION

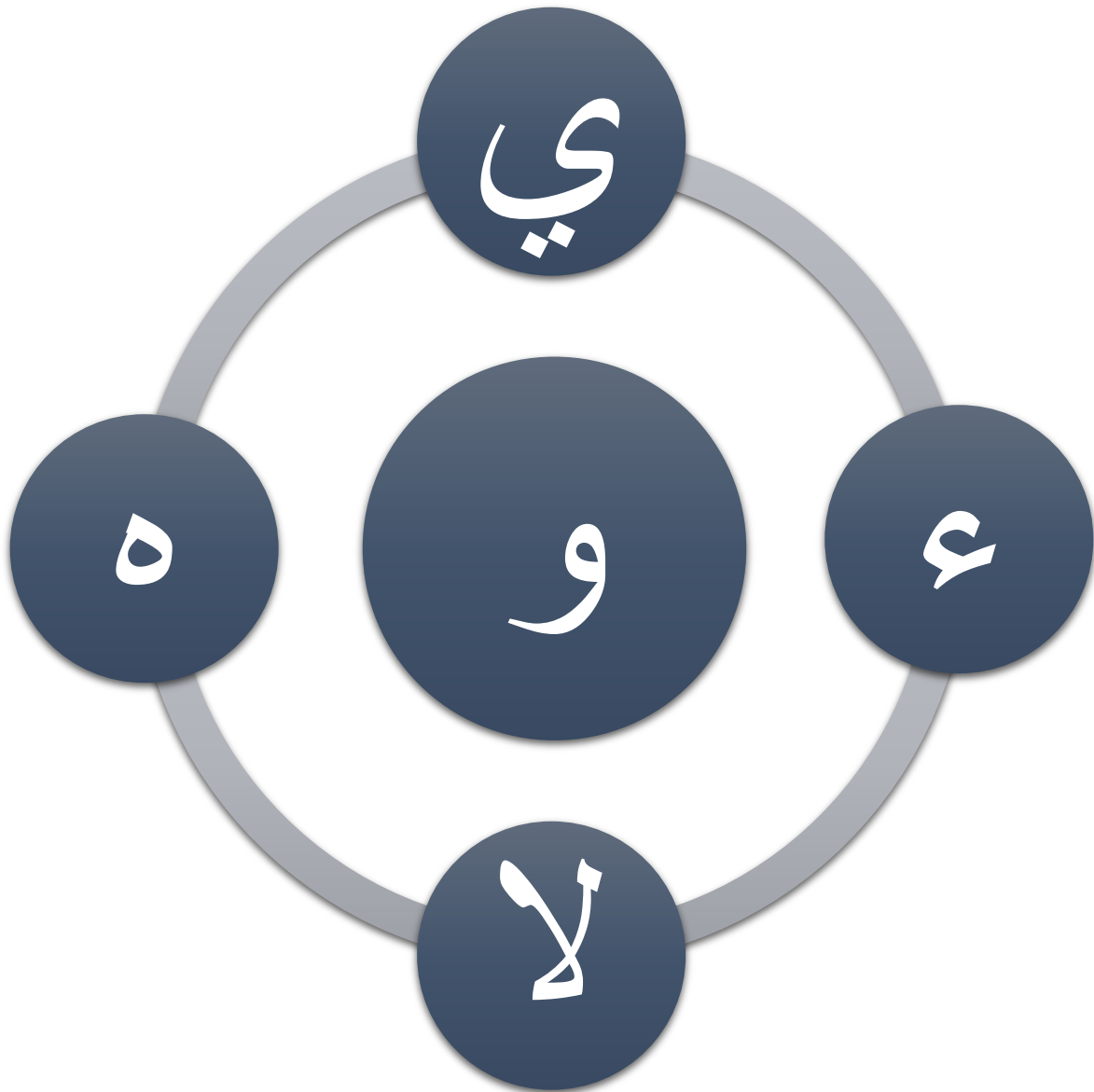

EXERCISE 144: READING ALPHABETS

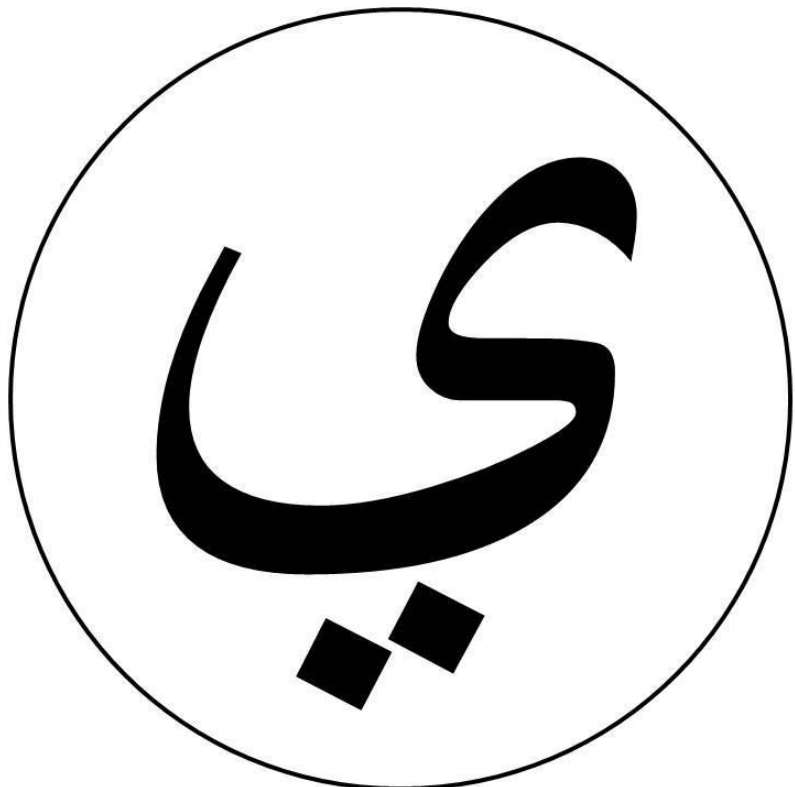
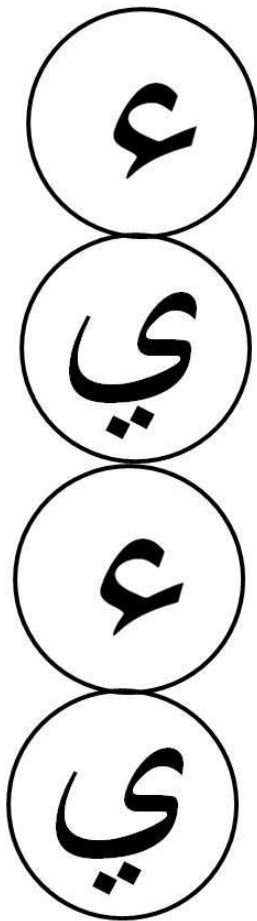
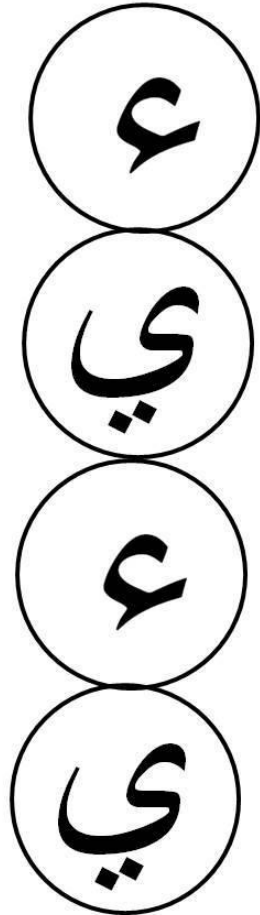
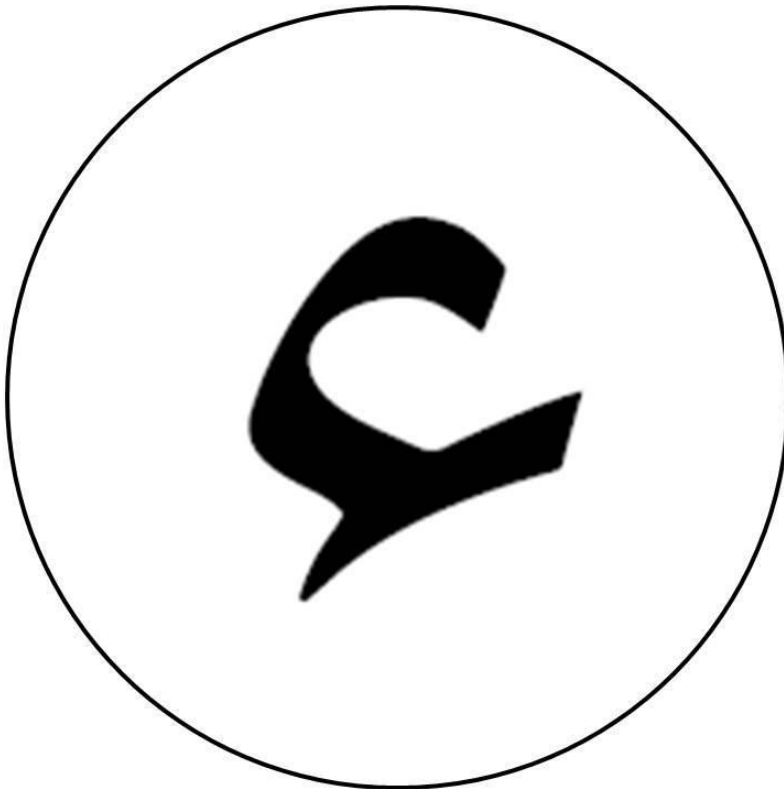



EXERCISE 145: IDENTIFY THE LETTERS

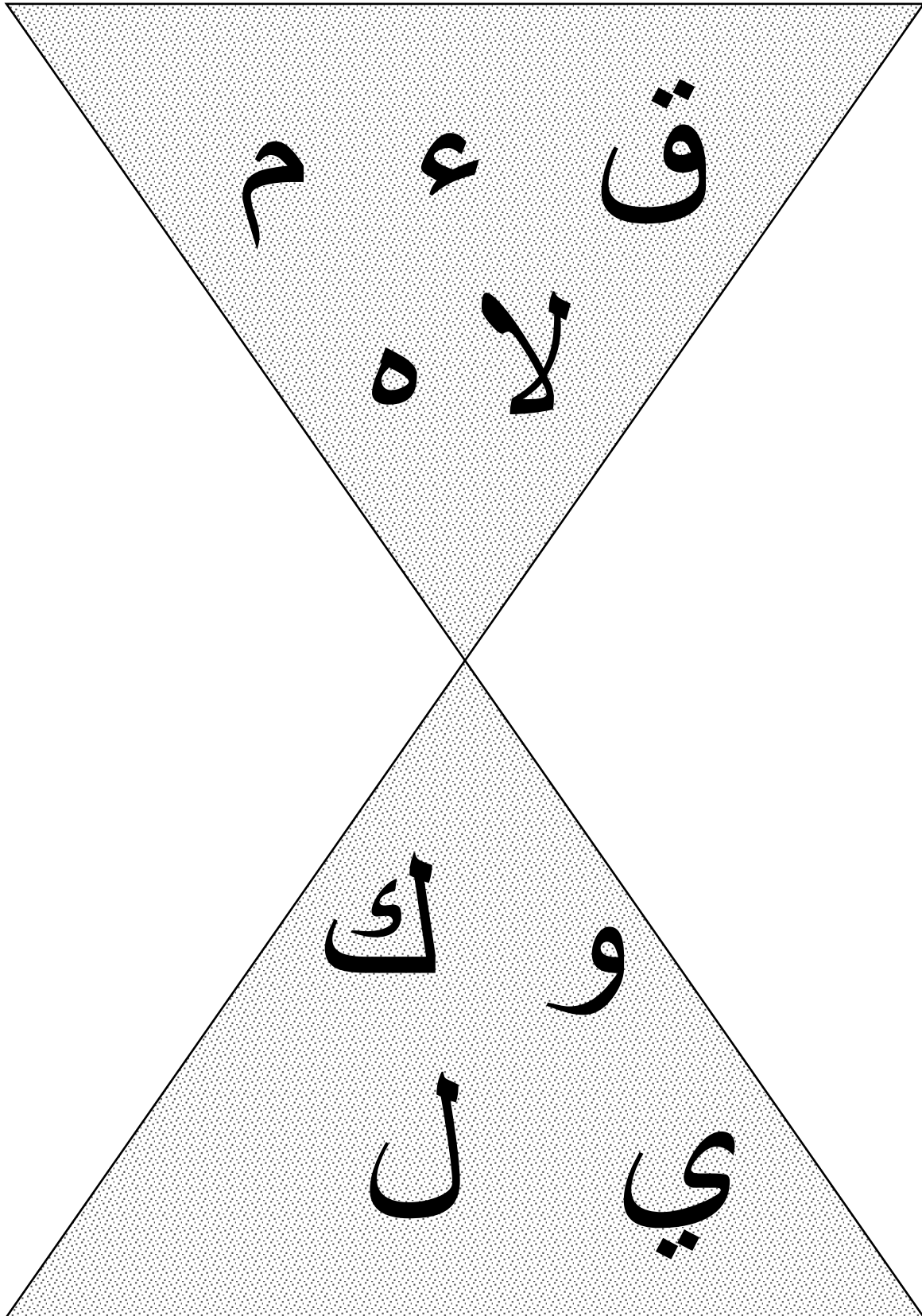

EXERCISE 146: IDENTIFY ALL THE LETTERS

ا ب ت ث ج  
ح خ د ذ ر  
ز س ش ص ض  
ط ظ ع غ ف  
ق ك ل م ن  
و ه ء ي





