



HAYDARI MADRASAH
(NAIROBI)

QUR'AN READING

CLASS TWO

(Age 5 yrs)

Name: _____



HAYDARI MADRASAH
(NAIROBI)

QUR'AN READING

CLASS 2 - Age 5 yrs

NO COPYRIGHT

September, 2020

These manuals on Qur'an reading, have been prepared to especially assist parents, teachers and students, who wish to teach and/or learn to recite the Holy Qur'an.

Please note that there is **NO COPYRIGHT** in regards to the reproducing of these manuals as long as the aim above is being fulfilled. Therefore there is **NO** requirement of a written permission from Haydari Madrasah Nairobi for reproducing this book for Madaris or personal use.

In case only part of this manual is reproduced, or the material therein edited in any manner, we request that any and all references to Haydari Madrasah Nairobi, be removed.

We do request however, that the manuals reproduced should **NOT** be for profit / commercial purposes. The cost of reproducing this manual may be recovered.

The Qur'an Reading Department
Haydari Madrasah (Nairobi)
hmn@saaj.co.ke

CONTENTS: CLASS 2 Qur'an Reading Syllabus

<u>SUBJECT</u>	<u>DETAILS</u>	<u>PAGE</u>
Surahs Memorisation <u>KG Revision</u>	Surah Al-Fatehah (Surah no: 1) Surah Al-Ikhlās (Surah no: 112) Surah Al-Asr (Surah no: 103) Surah Al-Kawthar (Surah no: 108)	
Surahs Memorisation <u>Class One Revision</u>	Surah An-Naas (Surah no: 114) Surah Al-Falaq (Surah no: 113) Surah Al-Feel (Surah no: 105) Surah An-Nasr (Surah no: 110)	
Surahs Memorisation <u>Class Two</u>	MID YEAR Surah Al-Qadr (Surah no: 97)	7
	END YEAR Surah Al-Lahab (Surah no: 111) Surah Al-Quraysh (Surah no: 106)	8 9
Kalema	Recitation of full Kalema with meaning	10
Dua e Faraj	Dua for the safety of our 12 th Imam	11
Short Duas	Dua at the time of breaking the fast Dua to be a Good Muslim	12 13
Islamic Phrases <u>Class Two</u>	Islamic Phrases and what they mean: InshaAllah, Ya Allah, Astaghfirullah	14

CONTENTS: Syllabus for Class Two.....continued

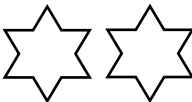
<u>SUBJECT</u>	<u>DETAILS</u>	<u>PAGE</u>
Islamic Phrases <u>KG & Class 1</u> <u>Revision</u>	Islamic Phrases and what they mean: Bismillah, Salaam/Wa Alaikum Salaam, Shukran, Jazakallah, Alhamdulillah, MashaAllah, Afwan, Salawaat, Fi Amaanillah and Subhaanallah	15
The Holy Qur'an	How Allah's Message came to us	16
The Holy Qur'an	How to Respect the Special Book	17
Motor Control	Motor Control Activities	18 - 25
Huruful Hijai Arabic Alphabet	Revision of all the Letters	26 - 123
Iraab	The Vowels in Arabic - Introduction	124 - 126
Iraab	The Short Vowel Fat-ha Introduction	127 - 139
Iraab	The Short Vowel Kasra - Introduction	140 - 152
Revision	What we have learnt in Class Two	153 - 158
Certificate	Congratulations You Did It 	159

SURAHS MEMORISATION - from KG to CLASS 3

The Holy Prophet (SAW) has said:

"The number of levels (stages) in Heaven is (equivalent to) the number of verses in the Qur'an (6236). Thus, when a reciter of the Qur'an enters into Heaven, it will be said to him: 'Go up one level for every verse that you can recite.' Thus, none will be in a higher level than the one who has memorized the entire Qur'an."

[Biharul Anwar, Volume 92 Page 22]

The table below classifies how the student will be tested for Surah Memorisation every year, by the Holy Madrasah. It will be to the child's advantage if parents prepare them ahead of time.

The chart from KG to Class 12 has been designed to cover the whole of the 30th Sipara (Juz Amma).

Some surahs have been repeated for testing purposes. Surahs which are required in our day to day lives, like Surah Jumuah and Surah Mulk have been added.

Parents are advised to train their child(ren) to memorise by reading from the Qur'an rather than only learning the Surah by heart.

When the child reads then memorizes, they learn the formation of the text, and they learn where the extra pull is required. It also ingrains the Surah well into their minds.

EFFECTIVE METHODS OF MEMORISATION

- 1) Teach an Ayah a day. This is a tried and tested method, where even when the student is ready to learn more, we restrain and teach only that one ayah (with meaning if one prefers). The next day a second ayah and so on. In a week the student has learnt 7 ayaat. This is stress free and an easy method.
- 2) Get help from YouTube. Type in the Surah Name and numerous options will come up. You can select your preferable reciter (we recommend Mishary Al Afasy) and the student can listen, read and learn at the same time. This will help build in the right makharij as well.
- 3) Download the App called Memorize. This is preferred by the older students for self-study.

SURAHS MEMORISATION - from KG to CLASS 3

<u>CLASS</u>	<u>MID - YEAR</u>	<u>END - YEAR</u>
KG	Surah Al-Fatihah (1) Surah Al-Ikhlash (112)	Surah Al-Kawthar (108) Surah Al-Asr (103)
1	Surah Al-Nas (114) Surah Al-Falaq (113)	Surah Al-Fil (105) Surah Al-Nasr (110)
2	Surah Al-Qadr (97)	Surah Al-Lahab (111) Surah Al-Quraysh (106)
3	Surah Al-Tin (95)	Surah Al-Kafirun (109)

SURAHS TO BE MEMORISED (MID - YEAR)

- ❖ Recitation of this Surah increases our Rizq (sustenance).
- ❖ If Surah Al-Qadr is recited 11 times before going to sleep, the reciter remains safe for the whole night.

SURAH AL-QADR

(THE MAJESTY)

SURAH NO: 97

REVEALED IN
MECCA

HAS 5 AYAT

بِسْمِ اللَّهِ الرَّحْمَنِ الرَّحِيمِ

إِنَّا أَنْزَلْنَاهُ فِي لَيْلَةِ الْقَدْرِ ﴿١﴾

وَمَا أَدْرَاكَ مَا لَيْلَةُ الْقَدْرِ ﴿٢﴾

لَيْلَةُ الْقَدْرِ خَيْرٌ مِنْ أَلْفِ شَهْرٍ ﴿٣﴾

تَنْزِيلُ الْمَلَائِكَةِ وَالرُّوحِ فِيهَا يَأْتِي رَبُّهُمْ مِنْ كُلِّ أَمْرٍ ﴿٤﴾

سَلَامٌ هِيَ حَتَّىٰ مَطَلَعِ الْفَجْرِ ﴿٥﴾

SURAHS TO BE MEMORISED (END - YEAR)**Surah Al-Lahab (111) AND Surah Al-Quraysh (106)**

- ❖ Reciting the Surah before sleeping, keeps the reciter safe in the night.
- ❖ The 6th Imam has advised that when we recite Surah Al-Lahab, we should curse Abu Lahab, since he mistreated the Holy Prophet (SAW) and was disrespectful to him.

SURAH AL-LAHAB**(THE FLAME)**

SURAH NO: 111

REVEALED IN
MECCA

HAS 5 AYAT

بِسْمِ اللَّهِ الرَّحْمَنِ الرَّحِيمِ

تَبَّتْ يَدَا أَبِي لَهَبٍ وَتَبَّ ﴿١﴾

مَا أَغْنَىٰ عَنْهُ مَالُهُ وَمَا كَسَبَ ﴿٢﴾

سَيَصْلَىٰ نَارًا إِذَا تَلَهَبَ ﴿٣﴾

وَأَمْرَأَتُهُ حَمَّالَةَ الْحَطَبِ ﴿٤﴾

فِي جِيدِهَا حَبْلٌ مِّن مَّسَدٍ ﴿٥﴾

SURAHS TO BE MEMORISED (END - YEAR)**Surah Al-Lahab (111) AND Surah Al-Quraysh (106)**

- ❖ If this Surah is recited on food, the ill-effects of the food are removed.
- ❖ Those with heart conditions should recite this Surah and then gently blow into some water and drink it.
- ❖ If a poor person recites this Surah before sunrise, Allah (SWT) will make it easy for him to get his sustenance.

SURAH AL-QURAYSH**(THE QURAYSH)**

SURAH NO: 106

REVEALED IN
MECCA

HAS 4 AYAT

بِسْمِ اللَّهِ الرَّحْمَنِ الرَّحِيمِ

لَا إِلَهَ إِلَّا قُرَيْشٌ ﴿١﴾

إِيْلَافِهِمْ رِحْلَةَ الشِّتَاءِ وَالصَّيْفِ ﴿٢﴾

فَلْيَعْبُدُوا رَبَّ هَذَا الْبَيْتِ ﴿٣﴾

الَّذِي أَطْعَمَهُمْ مِنْ جُوعٍ وَآمَنَهُمْ مِنْ خَوْفٍ ﴿٤﴾

K A L E M A

بِسْمِ اللَّهِ الرَّحْمَنِ الرَّحِيمِ

لَا إِلَهَ إِلَّا اللَّهُ مُحَمَّدٌ رَّسُولُ اللَّهِ عَلِيُّ وَليُّ اللَّهِ

وَصِيُّ رَّسُولِ اللَّهِ وَخَلِيفَتَهُ بِلاَ فَصْلِ

TRANSLITERATION

LA ILAHA ILLALLAH

MUHAMMADUR RASULALLAH

ALI YUN WALI YULLAH

WASI YUN RASULALLAH

WA KHALIIFATAHU BILAA FASL

TRANSLATION

There is No god but Allah

Muhammad is his Messenger

Ali is his Chosen One

He is the Helper of the Prophet

And He is the First Khalifa of the Prophet

SHORT DUA - DUA E FARAJ

اللَّهُمَّ كُنْ لِوَلِيِّكَ الْحُجَّةِ بْنِ الْحَسَنِ صَلَواتِكَ عَلَيْهِ
 وَعَلَى آبائِهِ فِي هَذِهِ السَّاعَةِ وَفِي كُلِّ سَاعَةٍ وَلِيًّا
 وَحَافِظًا وَقَائِدًا وَنَاصِرًا وَدَلِيلًا وَعَيْنًا حَتَّى تُسَكِّنَهُ
 أَرْضَكَ طَوْعًا تَتَّبِعُهُ فِيهَا طَويلاً

TRANSLITERATION:

Allaahumma kulle-Waliyyekal Hujjatibnil Hasan, Salawaatuka A'layhe Wa A'laa Aaabaa-Ehi, Fee Haazehis Saa-A'te, Wa Fee Kulle Saa-A'tin, Waliyyawn Wa Haafezan Wa Qaa-Edan Wa Naaseran, Wa Daleelan Wa A'ynan, Hattaa Tuskenahu Arzaka Taw-A'n, Wa Tomatte-A'hu Feehaa Taweelaa.

TRANSLATION:

O Allah! Protect your Vicegerent Hujjat (The Proof), son of Hassan and send Salutations upon him, and his ancestors, now as well as at all times,

(as our) Imam, Guardian, Supporter, and Guide until such time when you Bestow upon him the honour of heading the (Divine) Government.

And let the people be delighted in his reign, by bestowing Success, and by extending his reign.

SHORT DUAS

BEFORE BREAKING THE FAST

اللَّهُمَّ لَكَ صُومْتُ وَعَلَى رِزْقِكَ

أَفْطَرْتُ وَعَلَيْكَ تَوَكَّلْتُ

"Allahumma Laka Sumtu, Wa Alaa Rizqika

Aftartu, Wa Alaika Tawakkaltu"

O Allah, I have fasted for You, and opened my fast
from the food given by You, and on you I depend.



SHORT DUAS

DUA TO BE A GOOD MUSLIM

رَبَّنَا لَا تُزِغْ قُلُوبَنَا بَعْدَ إِذْ هَدَيْتَنَا وَهَبْ لَنَا

مِنْ لَدُنْكَ رَحْمَةً إِنَّكَ أَنْتَ الْوَهَّابُ ﴿٨﴾



"RABBANA LA TUZIGH QULUBANAA
BA'DA IDH HADAYTANAA WA HABLANAA
MIL LADUNKA RAHMATAN
INNAKA ANTAL WAH HAAB"

Our Lord! Let not our hearts deviate after you have guided us and grant us from yourself mercy. Indeed, you are the Bestower. (Surah Aale - 'Imran 3:8)

ISLAMIC PHRASES AND WHAT THEY MEAN

1.) When intending to do something, we say:

"Insha Allah" Meaning: "If Allah Wills"

2.) When in pain and distress,
we say:

"Ya Allah" Meaning: "O Allah"



3.) When making a mistake and seeking forgiveness,
we say:

"Astagh Firullah" Meaning: "I seek Allah's Forgiveness"



ISLAMIC PHRASES AND WHAT THEY MEAN

REVISION FROM CLASS KG and CLASS 1

Bismillahir Rahmaanir Rahim	In the name of Allah, the Most Kind, the Most Merciful
As Salaamu Alaikum Wa Rahmatullah Wa Barakatuhu	May the Mercy, Peace and Blessings of Allah be upon You
Wa Alaikum Salaam Wa Rahmatullah Wa Barakatuhu	And may the Peace, Mercy and Blessings of Allah be upon You
Jazakallahu Khair	May Allah reward you with good"
Shukraan Lillah	Thank you Allah
Alhamdulillah	All praise is due to Allah
Yar Hamuk Allah	May Allah have Mercy on you
Masha Allah	Whatever Allah Wills
Afwan	You are Welcome
Allahumma Salli Alaa Muhammadin Wa Ale Muhammad (Salawat)	O Allah, send Your Blessing on The Holy Prophet Muhammad (SAW) and his family
Fi Amaan Allah	In the trust of Allah
Subhaanallah	Glory be to Allah

HOW THE HOLY QUR'AN CAME TO US

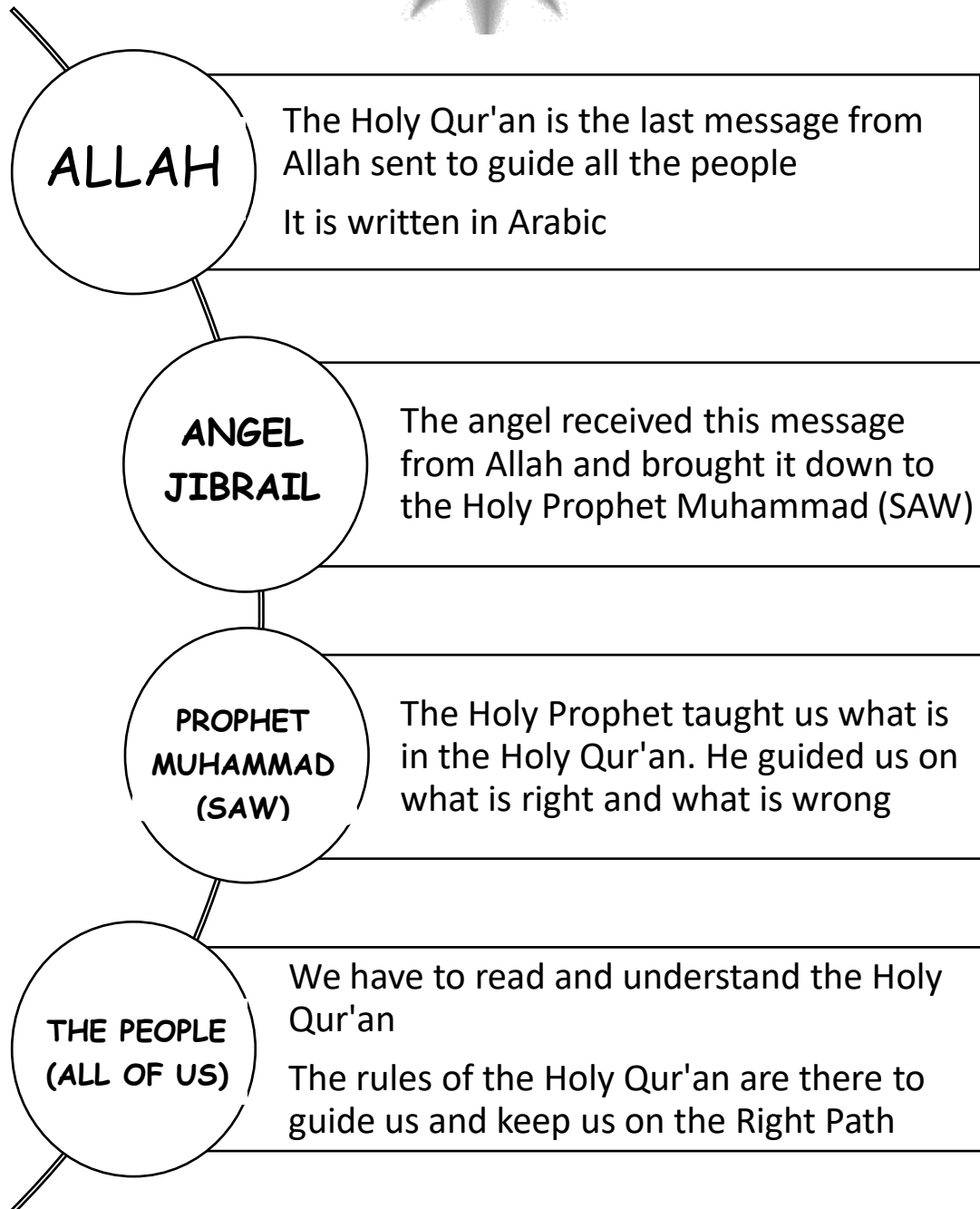
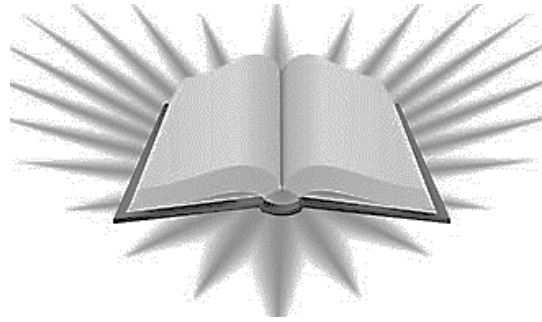

HOW TO RESPECT THE HOLY QUR'AN

- 1.) Before we recite the Holy Qur'an we should do Wudhoo. We should not touch the writing of the Qur'an without Wudhoo.
- 2.) When passing the Qur'an to someone, we should NOT toss it or throw it. We should pass it with respect.

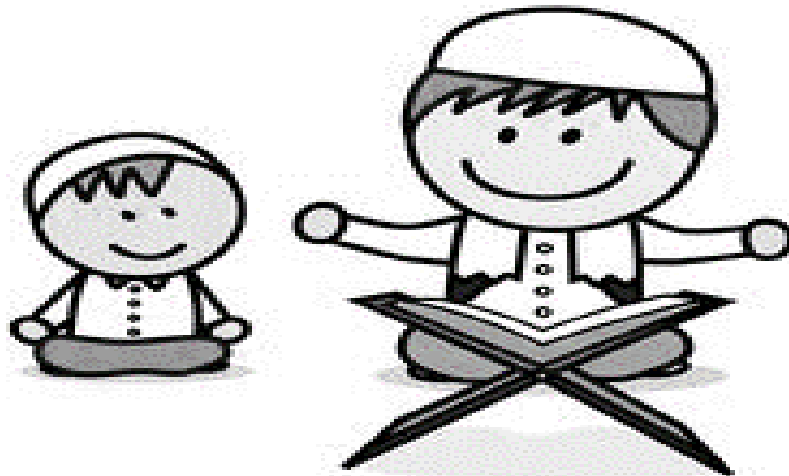

- 3.) When we finish reading the Qur'an, we should not leave it open.
- 4.) When we recite the Holy Qur'an, we should not be hasty. We should recite it slowly and sweetly.

MOTOR CONTROL

Exercises 1 - 7 in the following pages have been designed to assist the child in his/her handwriting skills.

Connecting the lines or the dots, using the Eye-Hand co-ordination will assist in establishing their motor control and movement in making the formation of the letters.

Make sure of the following:

- 1.) The correct sitting Posture of the body is important. The child should be comfortable
- 2.) The grip of the Pencil is also important. In the initial stages, parents/teachers should assist the child in the movement over the lines/dots. This will help in the co-ordination of the eye-hand-pencil connection



EXERCISE 1: MOTOR CONTROL ACTIVITY

Make the pattern by joining the dots and colour

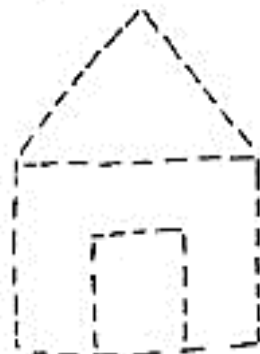
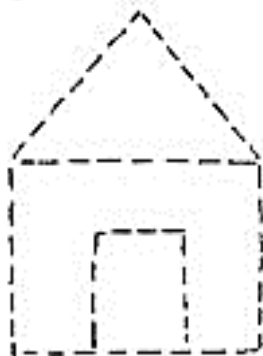
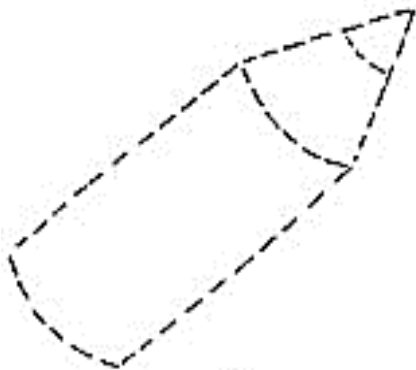
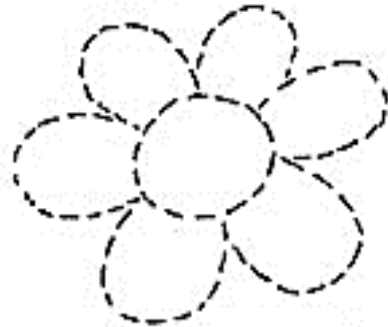
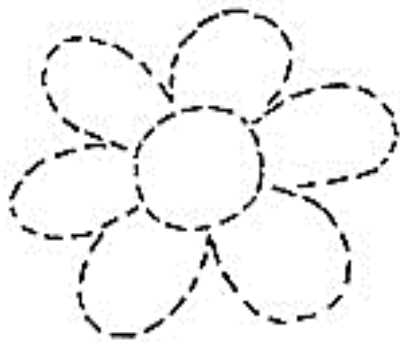
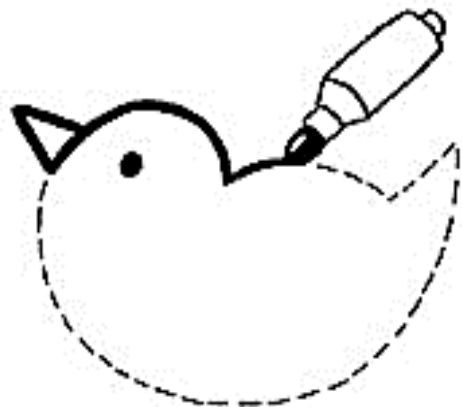
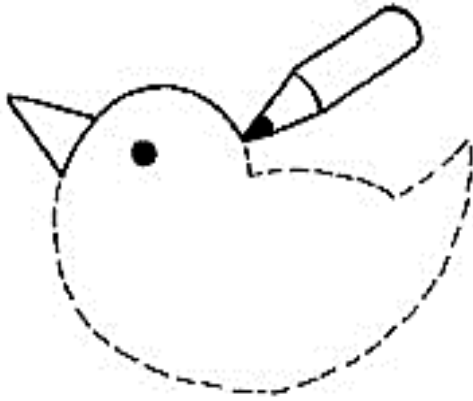

EXERCISE 2: MOTOR CONTROL ACTIVITY

Make the pattern by joining the dots and colour

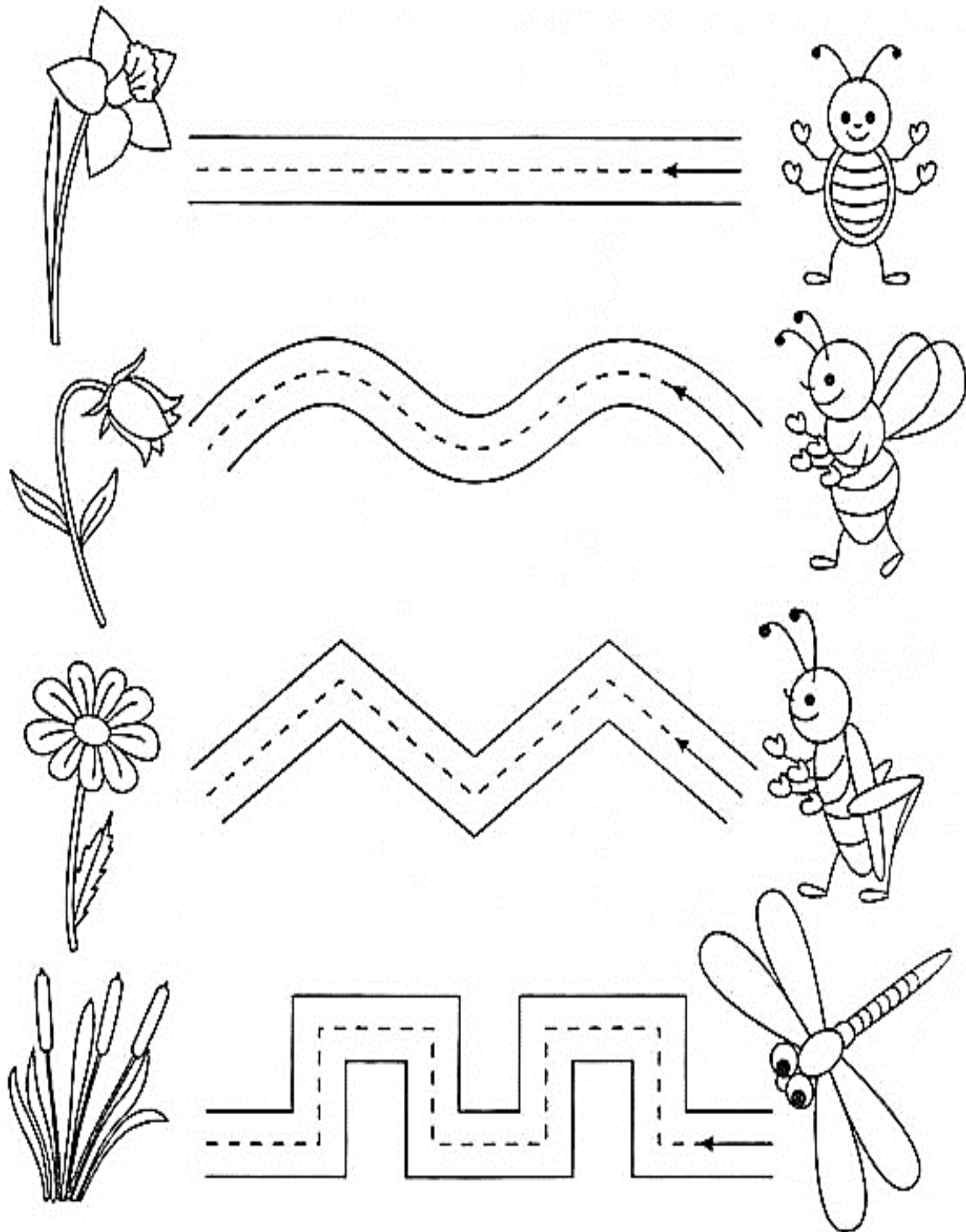

EXERCISE 3: MOTOR CONTROL ACTIVITY

Make the pattern by joining the dots and colour

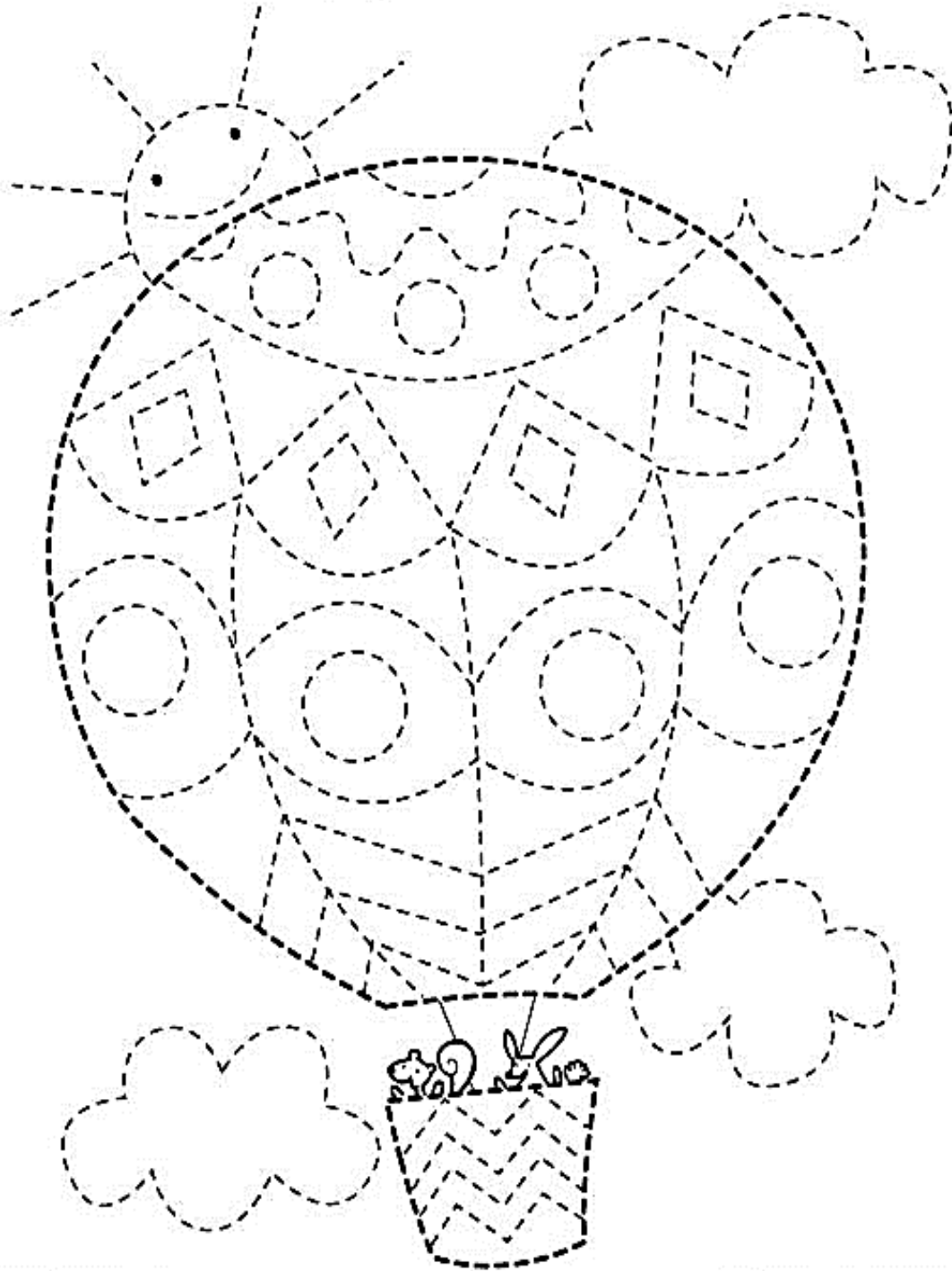

EXERCISE 4: MOTOR CONTROL ACTIVITY

Help the Rabbit to reach the Carrot and colour

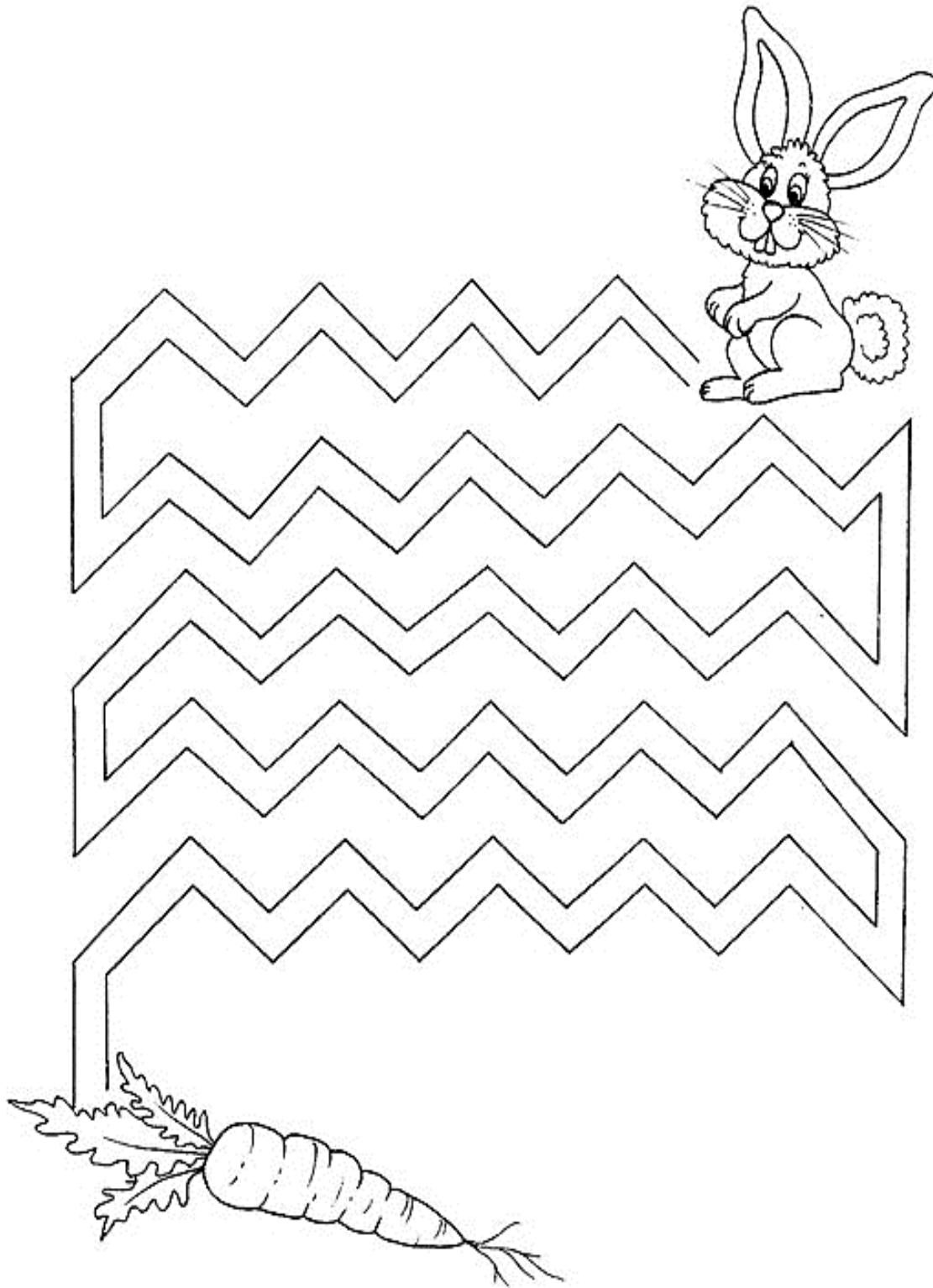

EXERCISE 5: MOTOR CONTROL ACTIVITY

Make the pattern by joining the dots and colour



EXERCISE 6: MOTOR CONTROL ACTIVITY

Follow the arrow to reach the animal & colour

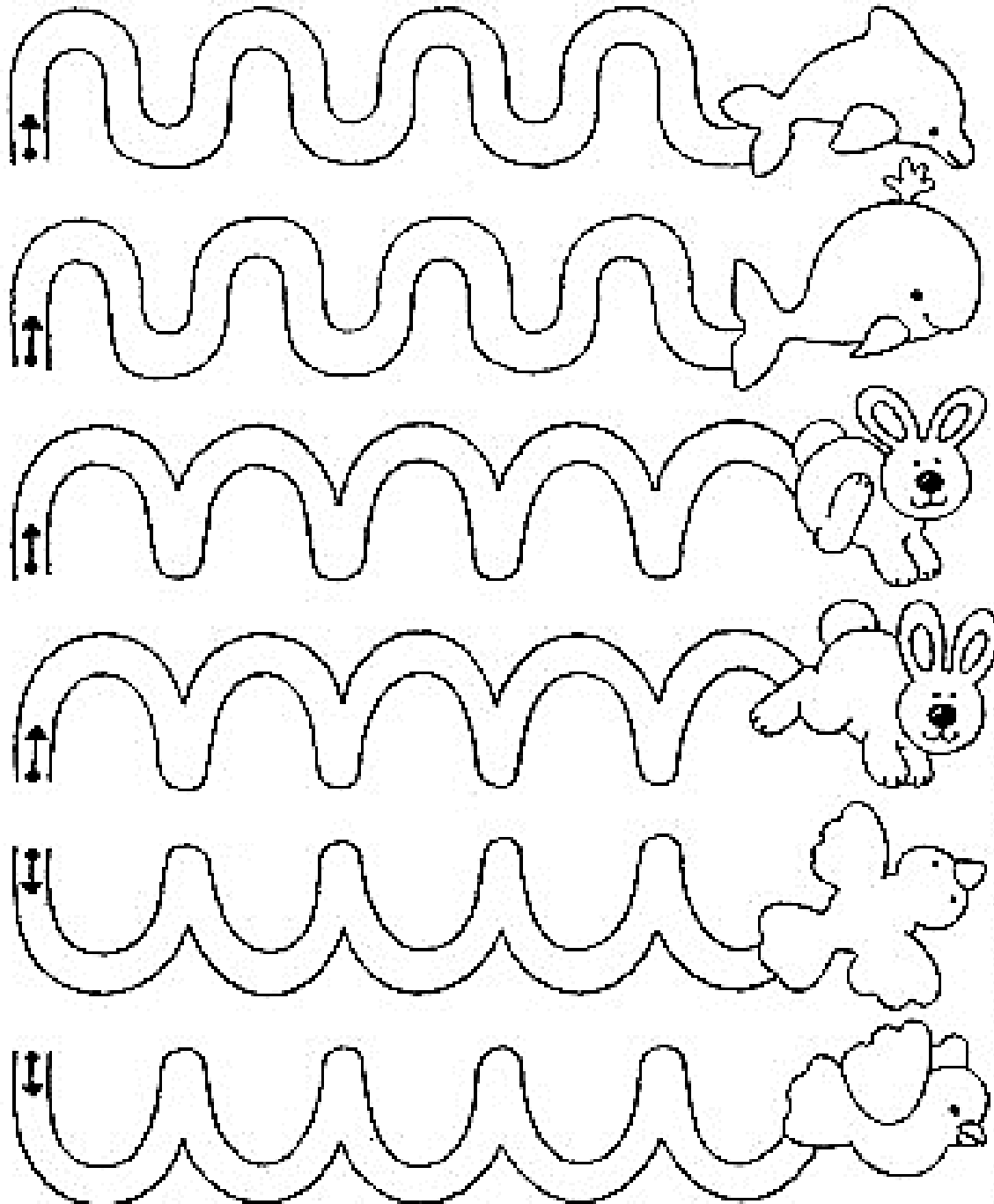

EXERCISE 7: COLOUR THE ALPHABET TASBIH

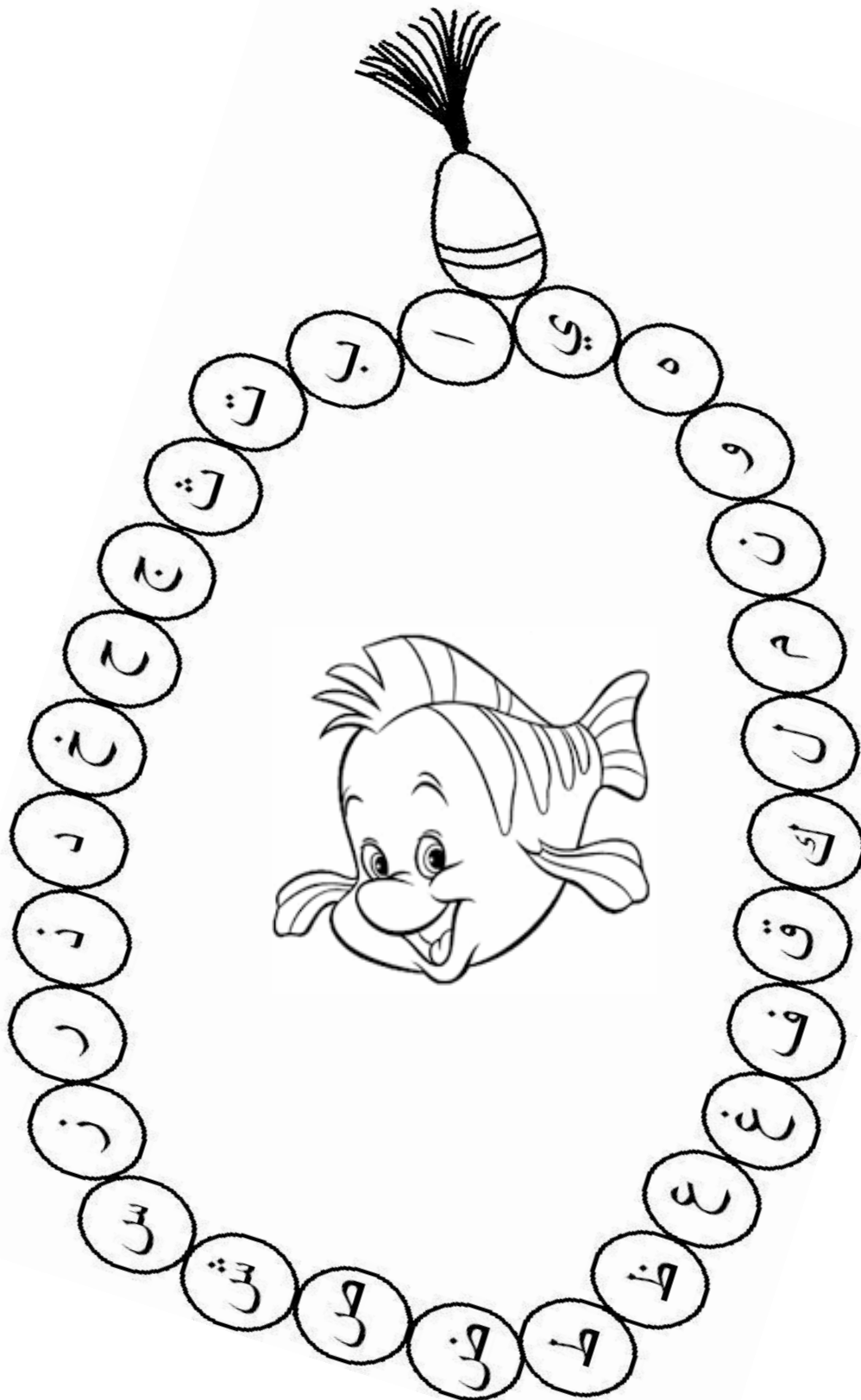

ARABIC ALPHABETS CHART (HURUFUL HIJAI)LETTER NAMES & SOUNDS

ج	ث	ت	ب	ا
Jim (ja)	The (th)	Te (ta)	Be (ba)	Alif (a-Light)
ر	ذ	د	خ	ح
Re (ra)	Dhal (dh)	Dal (da)	Khai (kh)	Hai (ha-Light)
ض	ص	ش	س	ز
Dhaad (dha)	Saad (ssa)	Shin (sh)	Sin (sa)	Ze (za)
ف	غ	ع	ظ	ط
Fe (fa)	Ghayn (gha)	Ayn (a-heavy)	Zhe (zha)	Tta (tta)
ن	م	ل	ك	ق
Nun (na)	Mim (ma)	Lam (La)	Kaf (ka)	Qaf (Qa)
لا = ا + ل	ي	ه هه	و	
(Laa) LamAlif = Alif + Lam	Ye (ya)	Hai (ha-heavy)	Waw (wa)	

ARABIC ALPHABETS CHART (HURUFUL HIJAI)

EXERCISE 8: Write on the Letters

ج	ث	ث	ب	ا
ر	ذ	د	خ	ح
ض	ص	ش	س	ز
ف	غ	ع	ظ	ط
ن	م	ل	ك	ق
ل + ا = لا	ي	ه	ه	و

EXERCISE 9: LETTER RECOGNITION

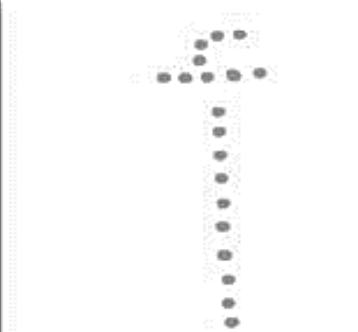
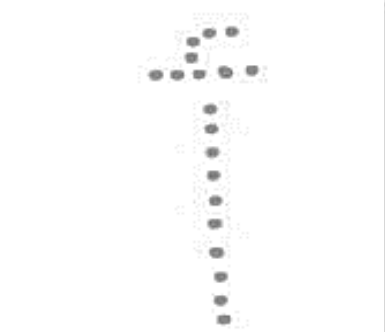
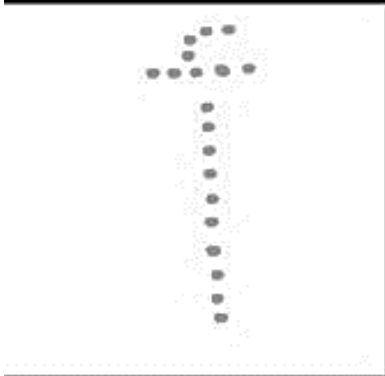
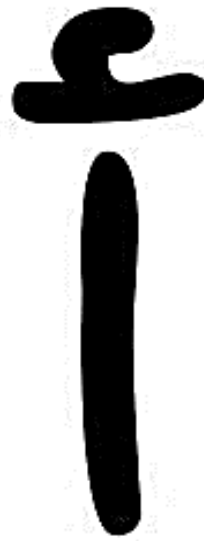

EXERCISE 10: LETTER RECOGNITION

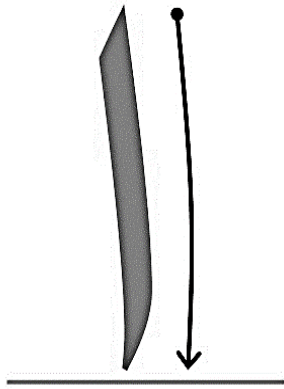

Alif makes the sound 'ai' as in air

اسد Asad

Read

Alif Alif Alif Alif Alif Alif

Remember to start on this side in Arabic

Alif Alif

Alif Alif Alif Alif Alif

EXERCISE 11: LETTER RECOGNITION

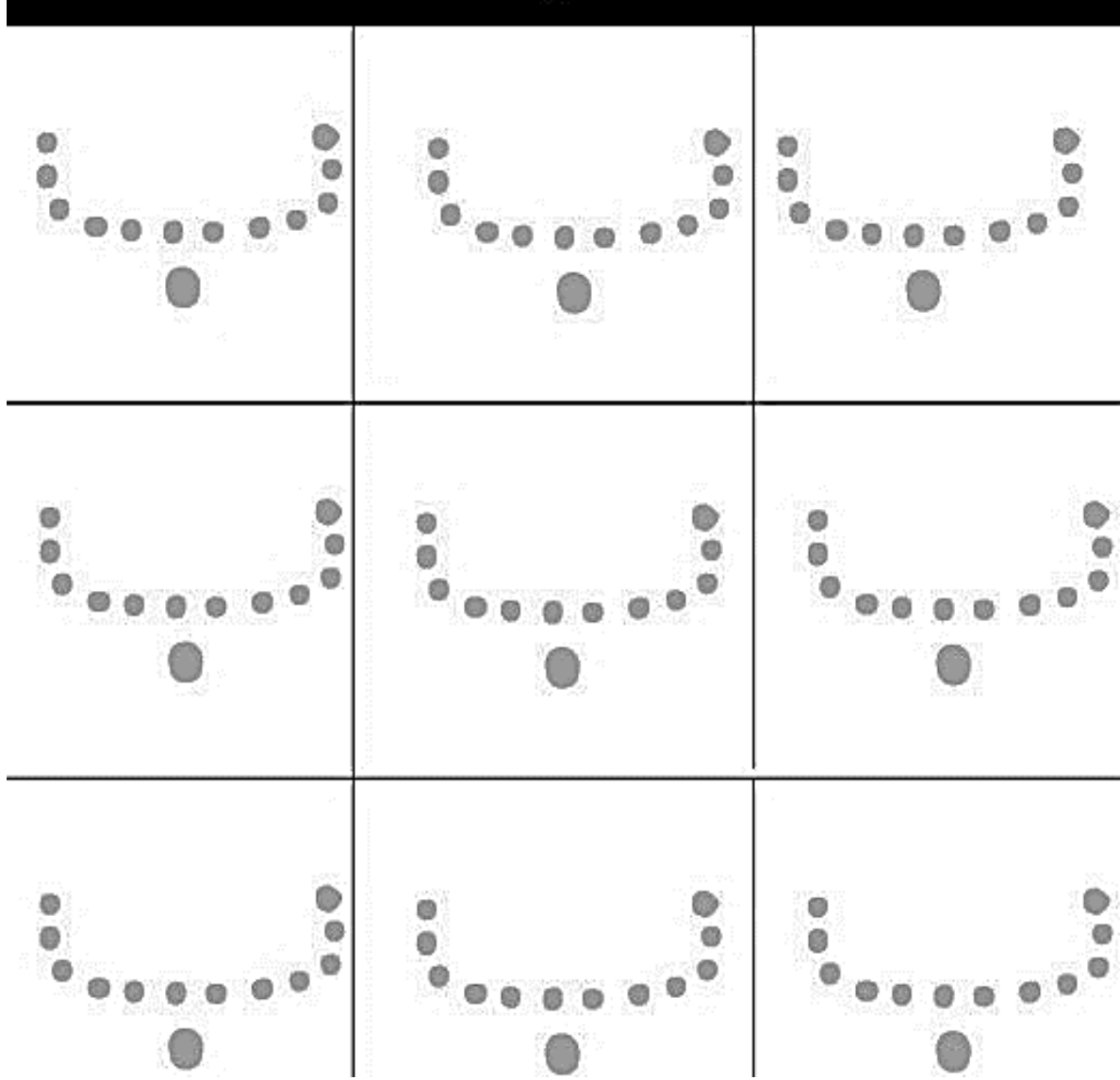
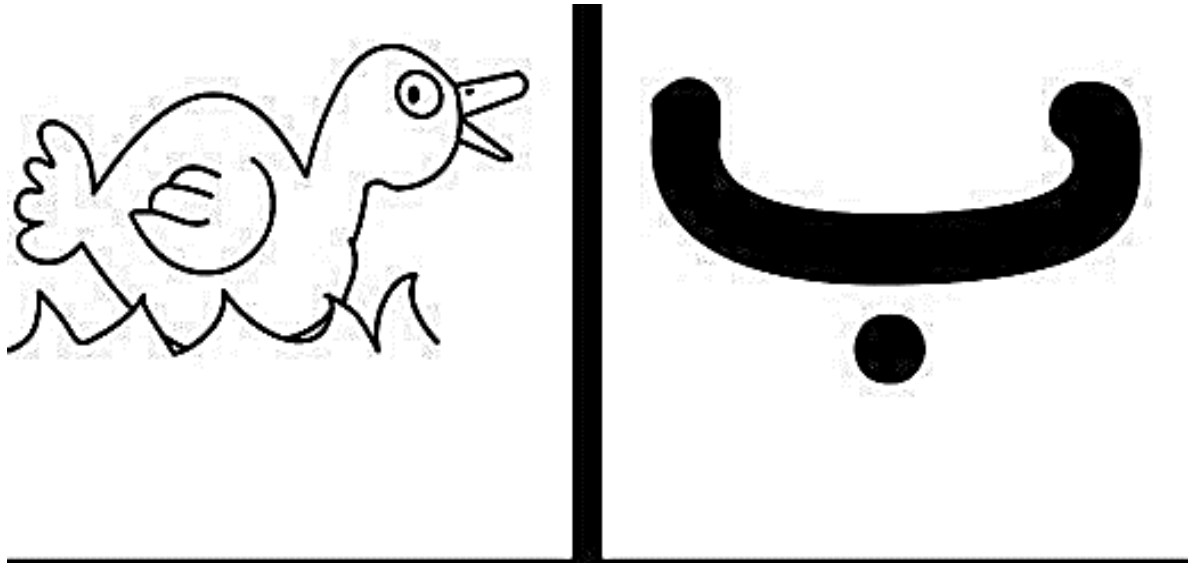

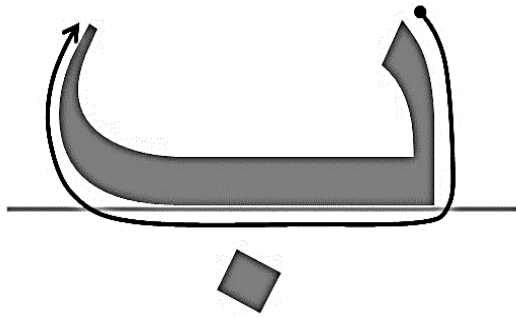
EXERCISE 12: LETTER RECOGNITION

Ba makes the sound 'ba' as in bat

بَطَّة Batta

Read

ب ب ب ب ب ب

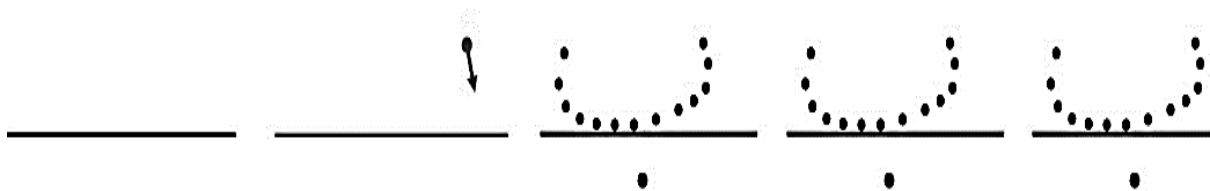

EXERCISE 13: LETTER RECOGNITION

Colour only the cakes which have the letter ا

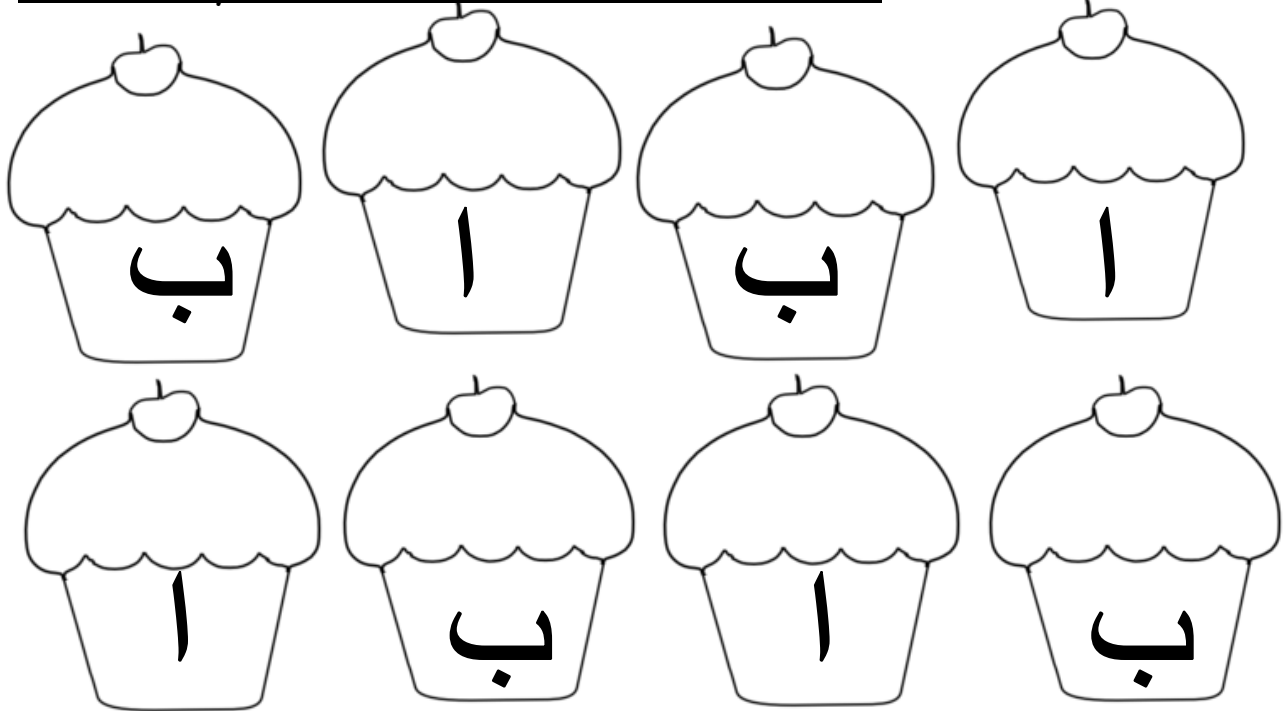
**EXERCISE 14: LETTER RECOGNITION**

Colour only the cars which have the letter ب

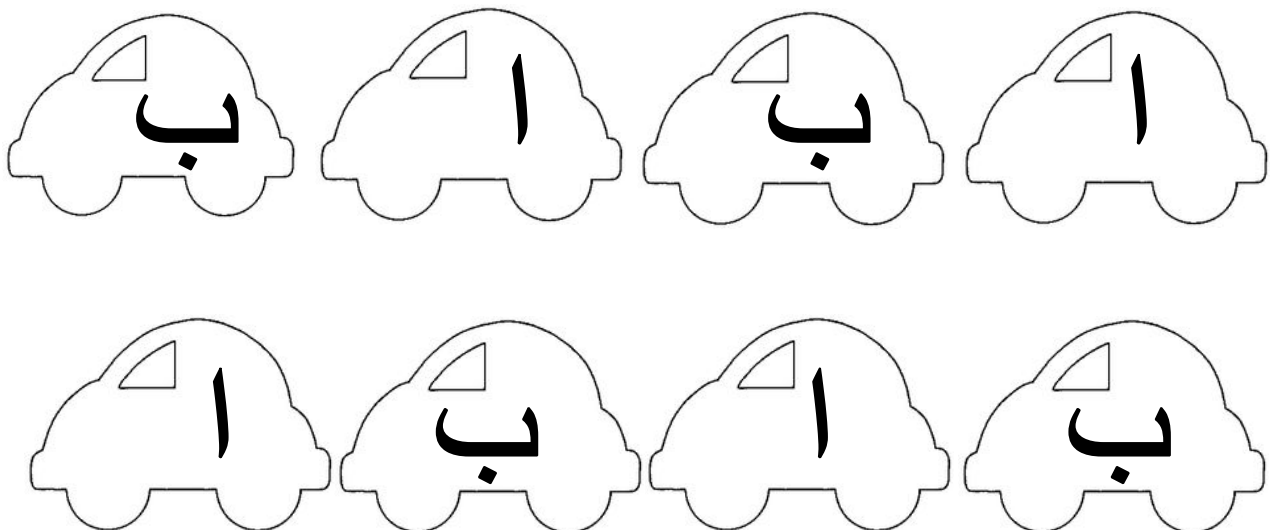

EXERCISE 15: LETTER RECOGNITION

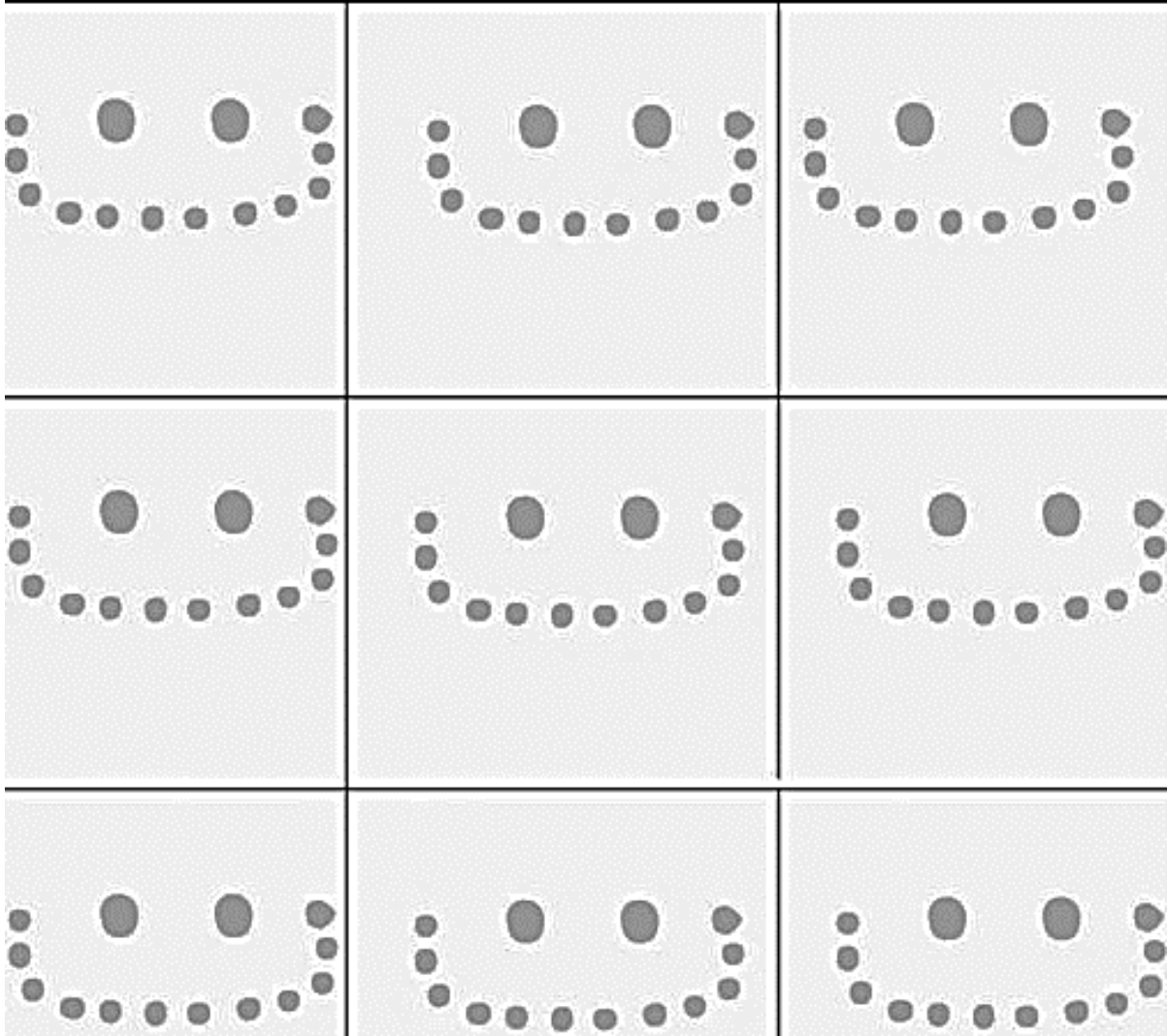
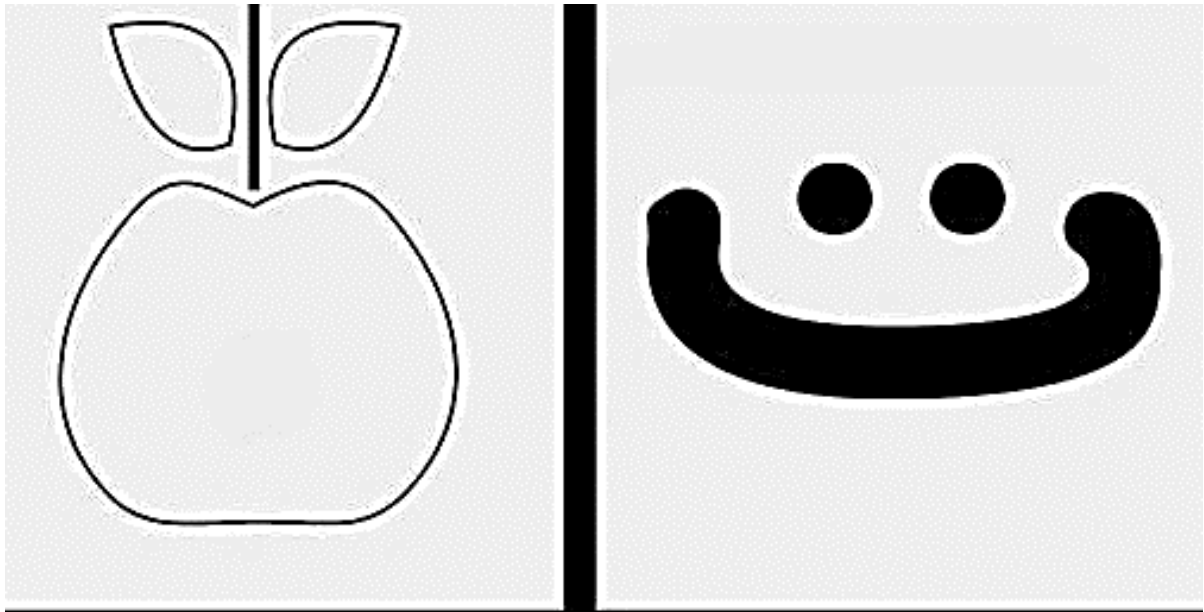

EXERCISE 16: LETTER RECOGNITION

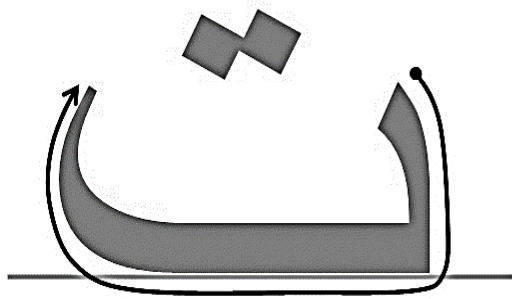

Ta makes the sound 'ta' as in Ta

تاج Taaj

Read

ت ت ت ت ت ت



EXERCISE 17: LETTER RECOGNITION

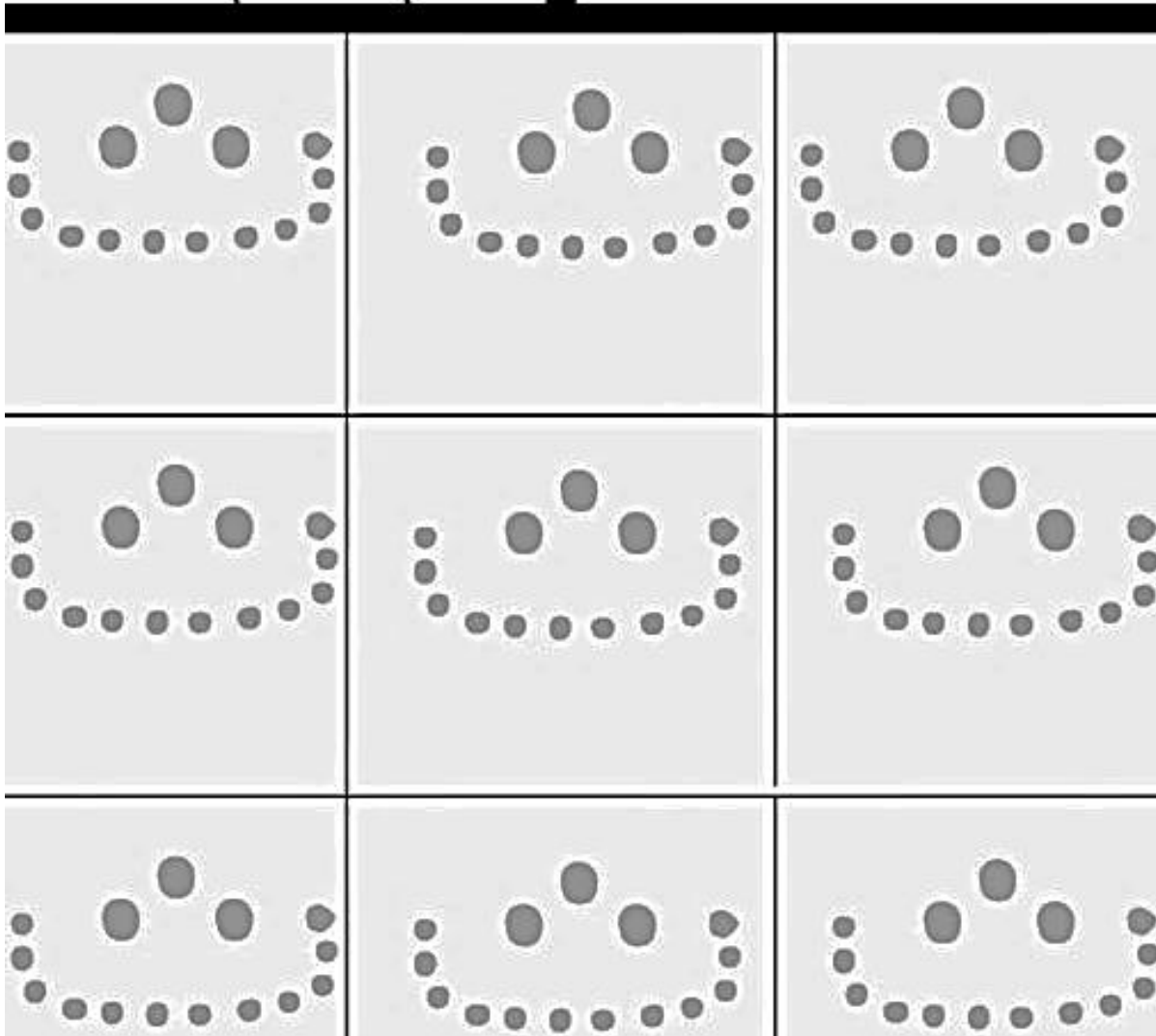
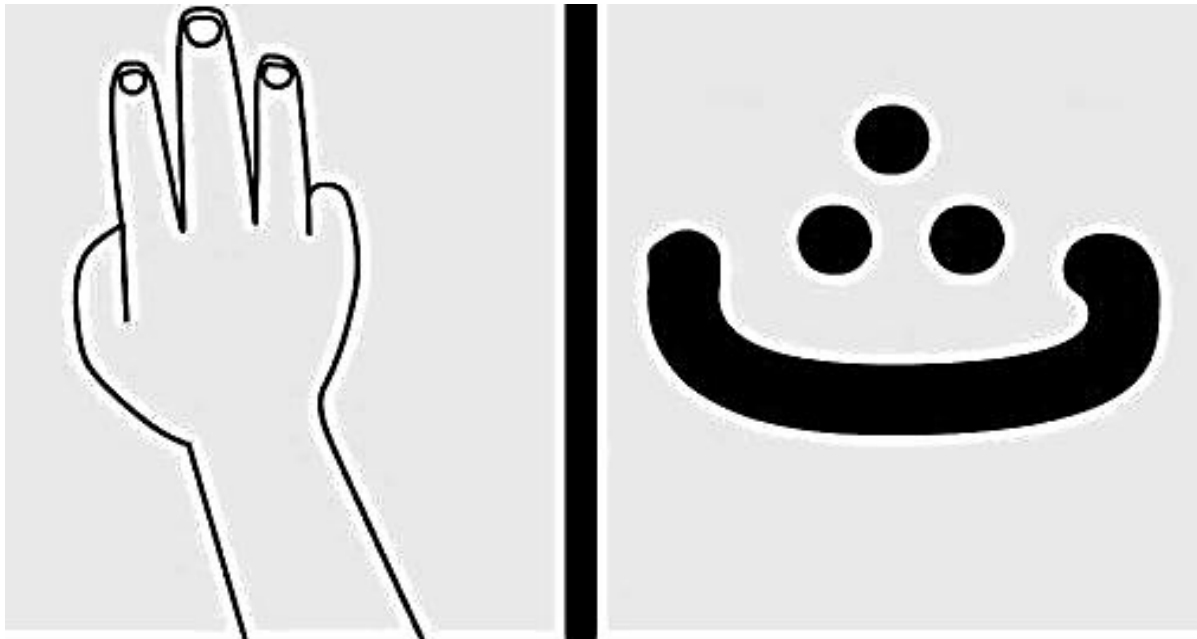

EXERCISE 18: LETTER RECOGNITION

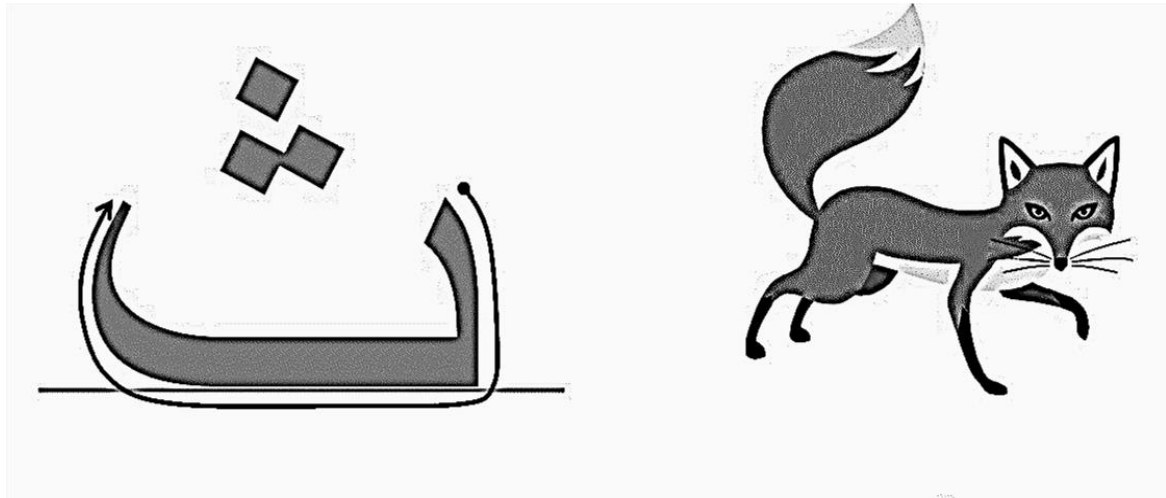

Tha makes the sound 'tha' as in thank ثعلب Tha'lab

Read

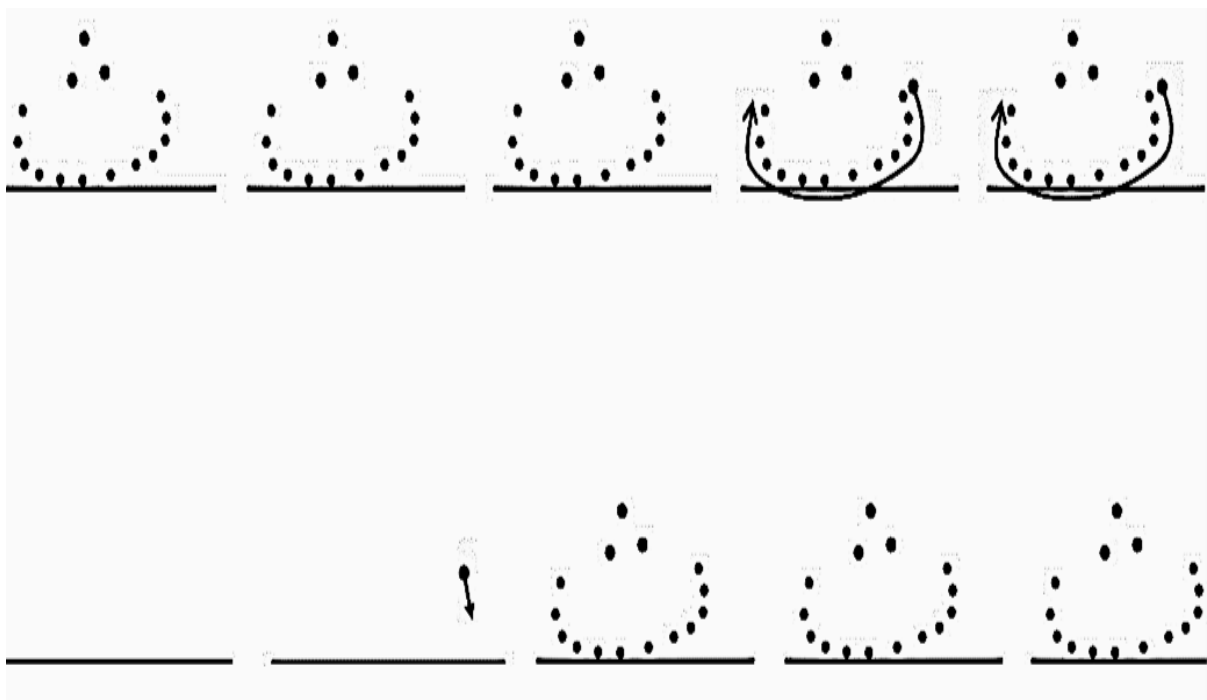

EXERCISE 19: LETTER RECOGNITION

Colour only the flowers which have the letter ت ت

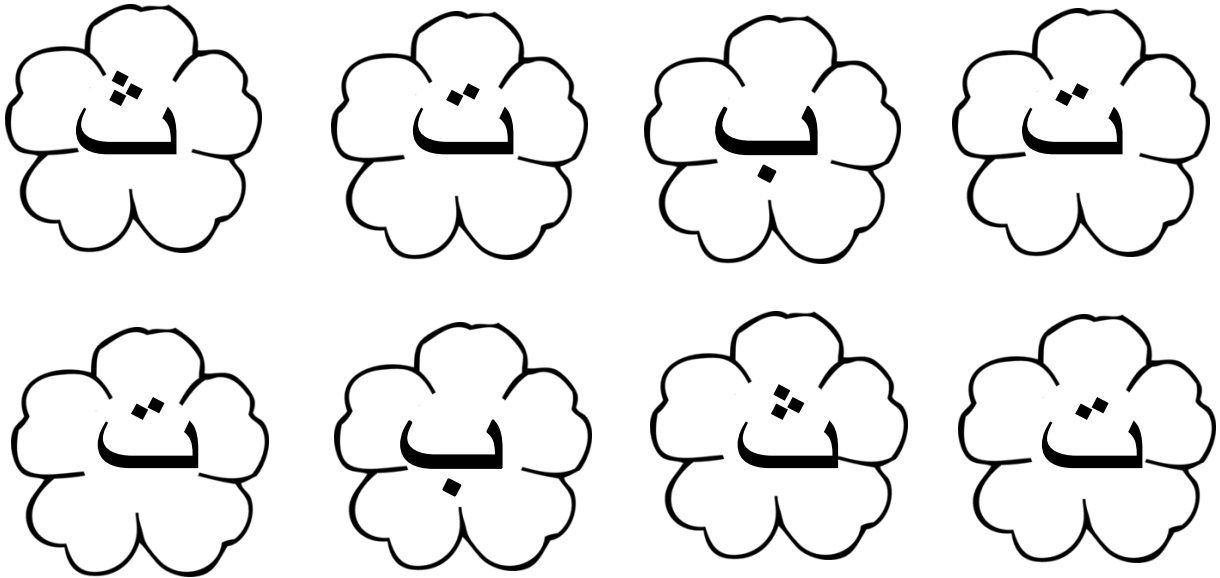
**EXERCISE 20: LETTER RECOGNITION**

Colour only the Rabbits which have the letter ت ت

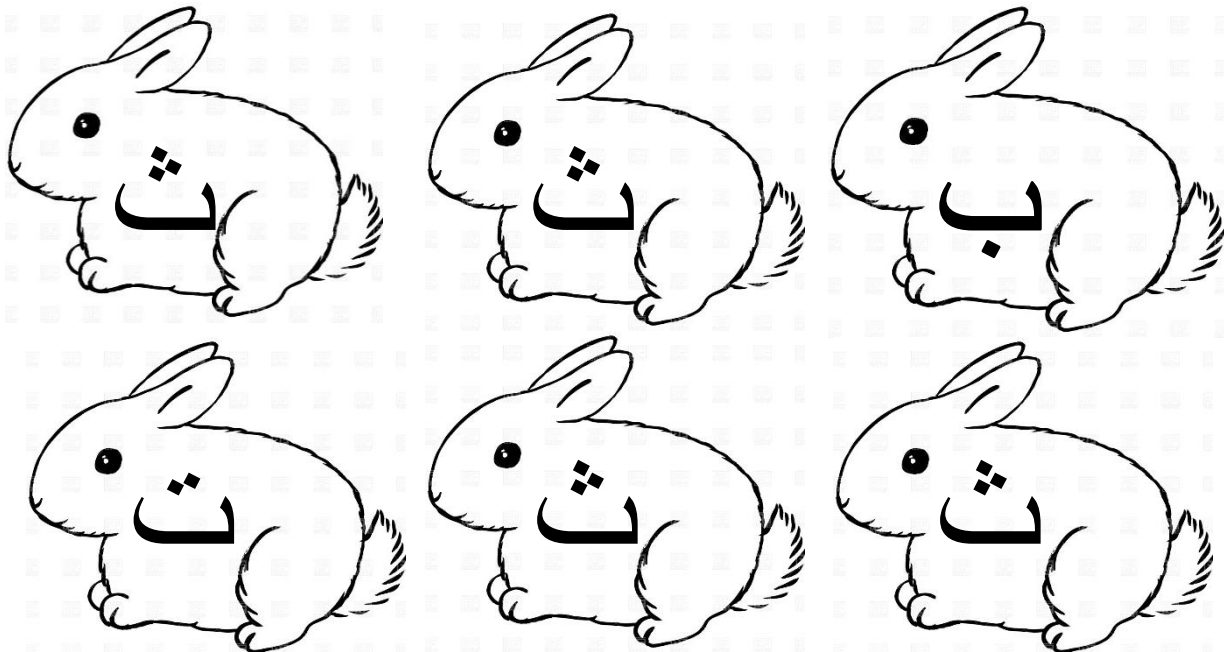

EXERCISE 21: COLOURING EXERCISE**RECOGNISING LETTERS ث TO ا**

Colour the picture below according to the letters.

ث	ث	ب	ا
Red	Yellow	Blue	Black



EXERCISE 22: LETTER RECOGNITIONCircle the correct matching letter as shown

ا	ث	ث	ا	ب	=	ا
ب	ب	ث	ث	ب	=	ب
ث	ب	ث	ث	ا	=	ث
ث	ث	ب	ث	ا	=	ث

EXERCISE 23: CONNECT THE MATCHING LETTERS

ا	ث
ث	ا
ث	ب
ب	ث

EXERCISE 24: LETTER RECOGNITION

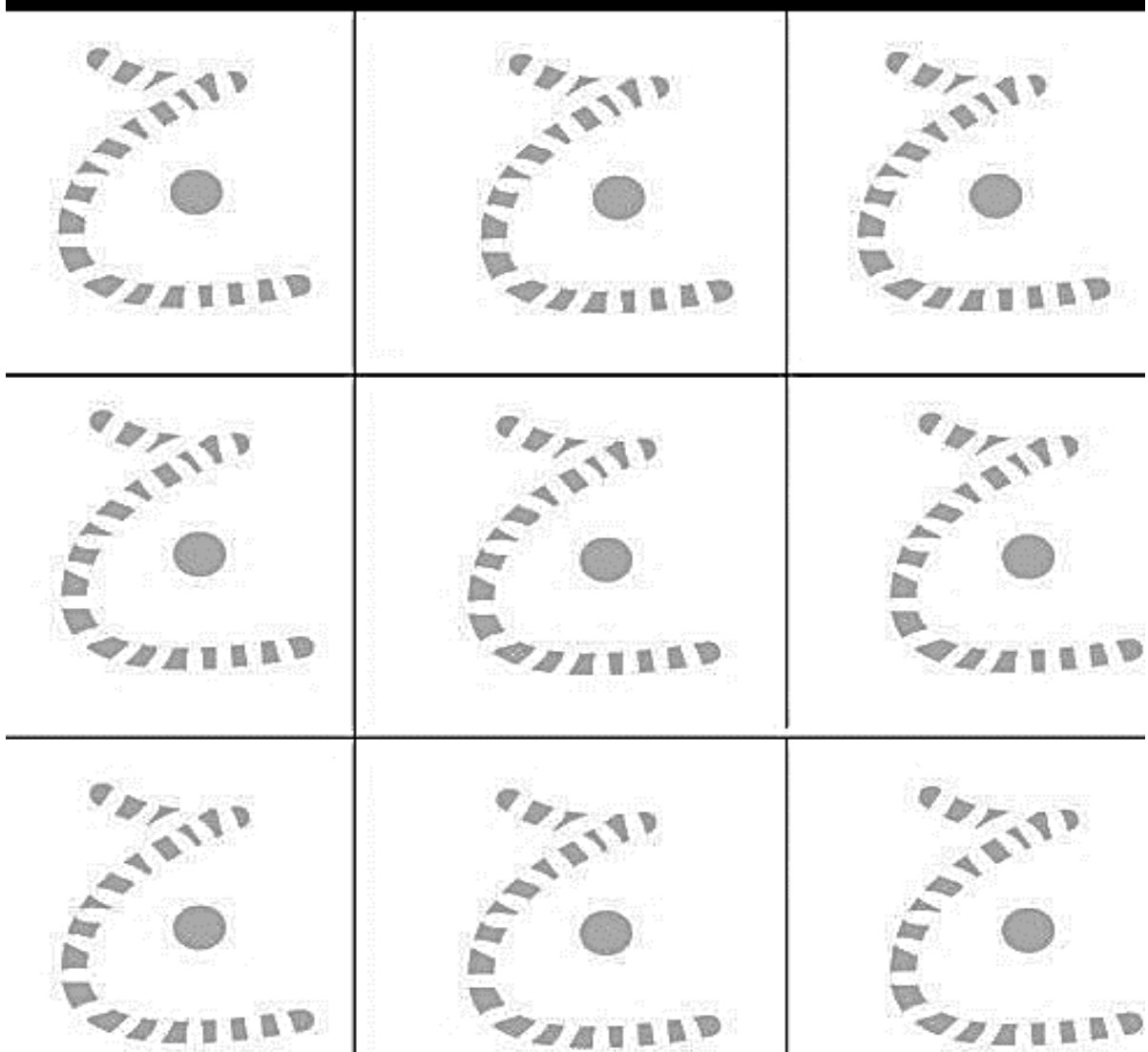
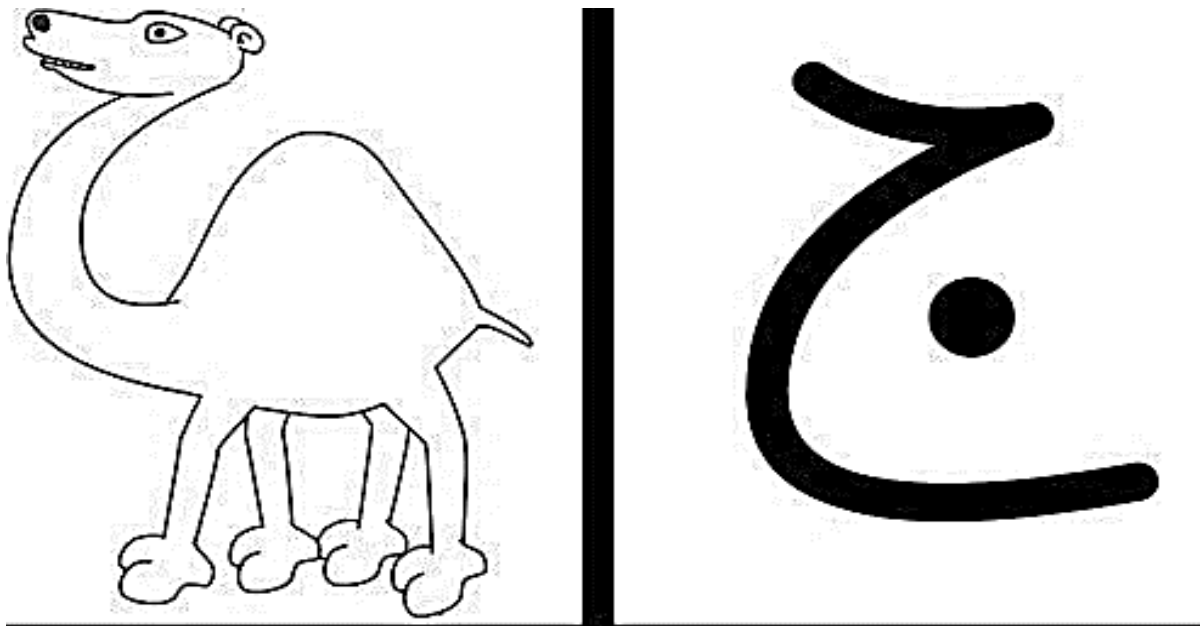

EXERCISE 25: LETTER RECOGNITION

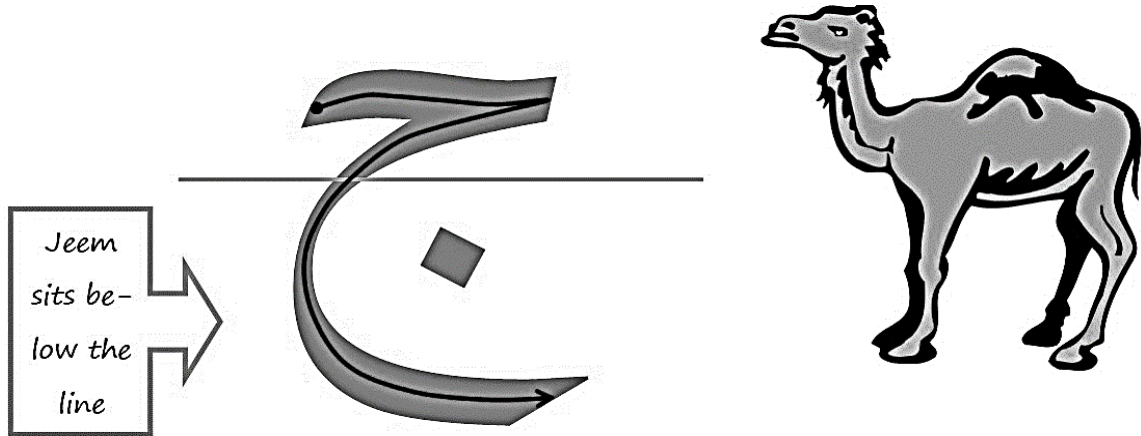

Jeem makes the sound 'ja' as in jam **جمال** Jamal

Read

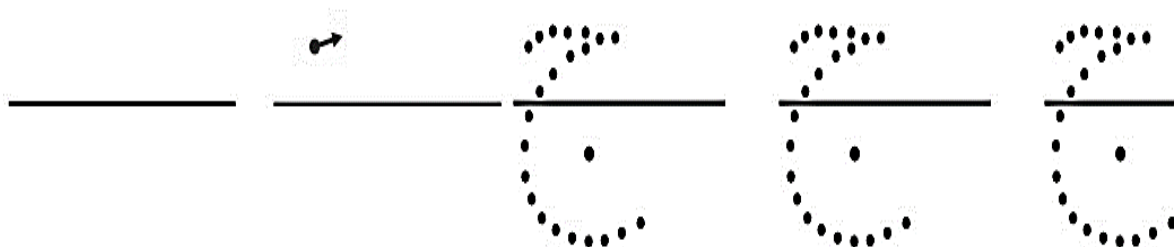
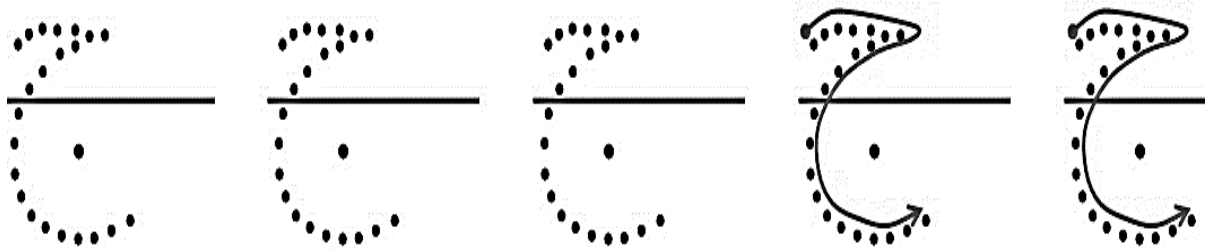

EXERCISE 26: LETTER RECOGNITION

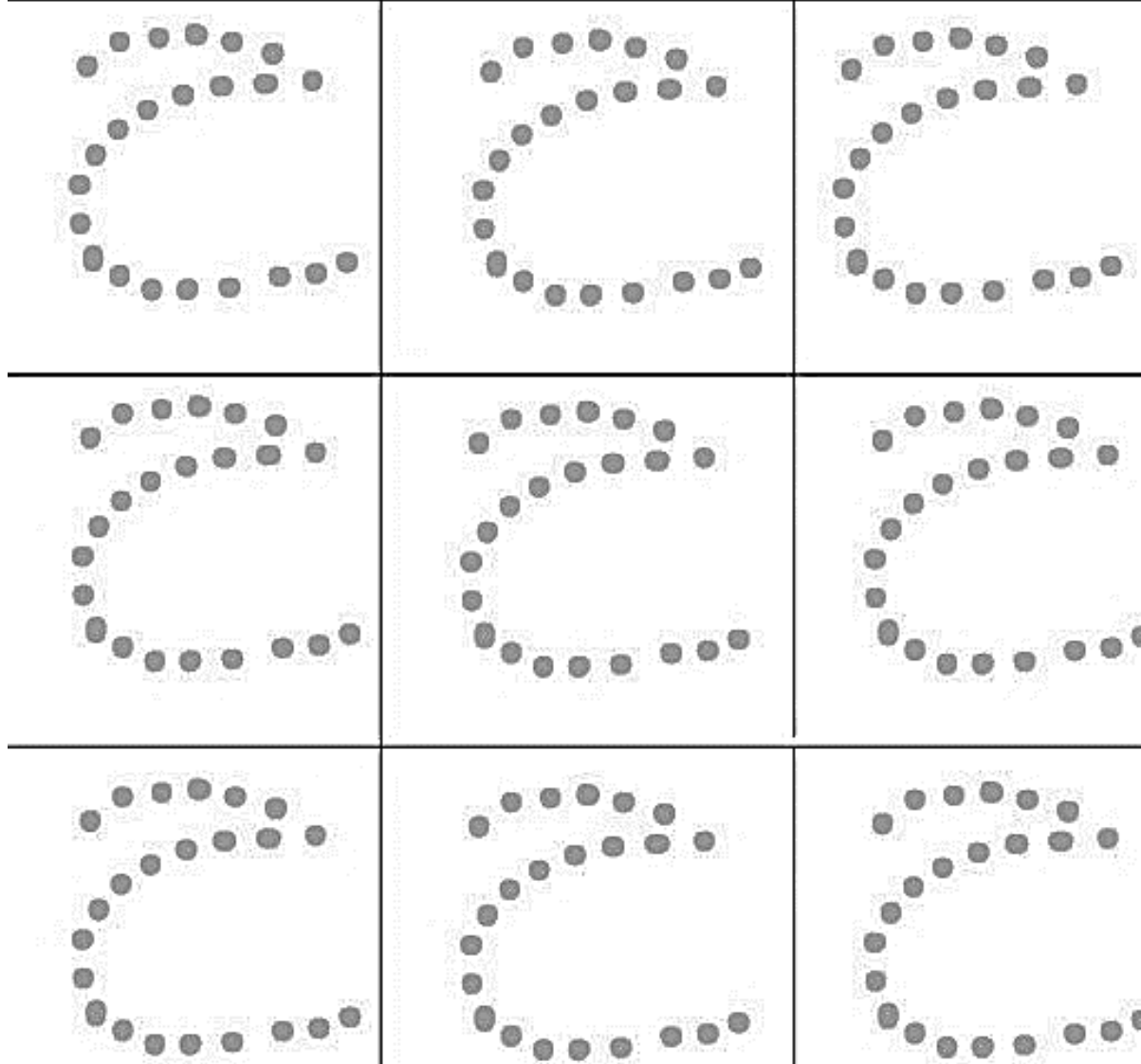
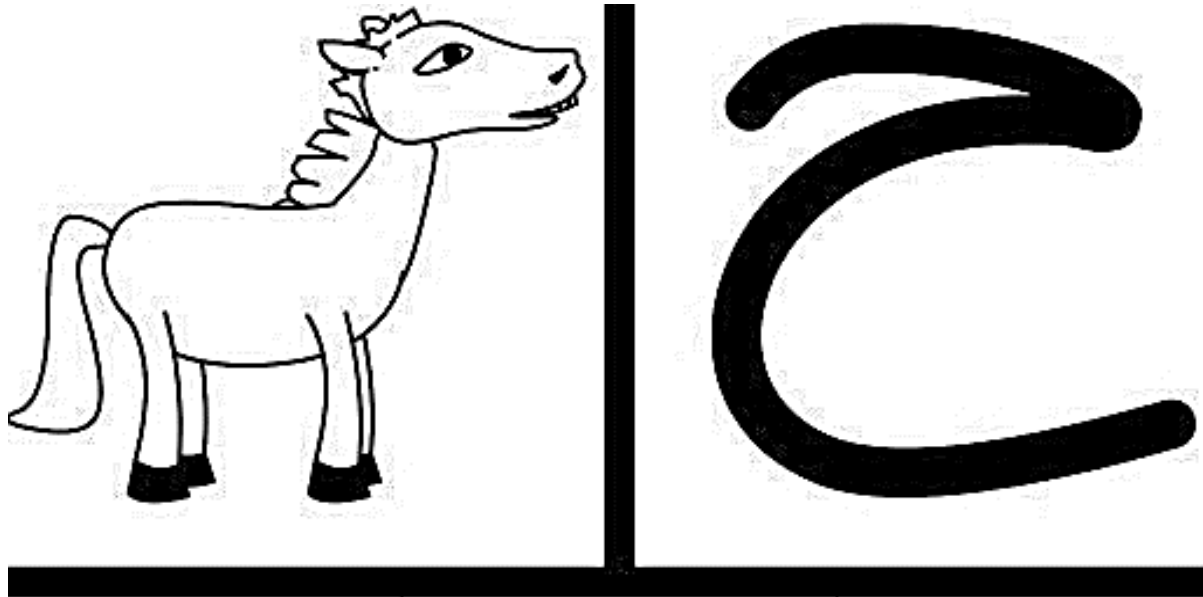

EXERCISE 27: LETTER RECOGNITION

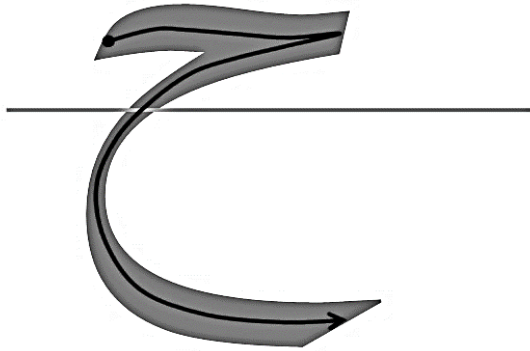

Ha makes the sound 'ha' as in have

حرباء Harbaa

Read

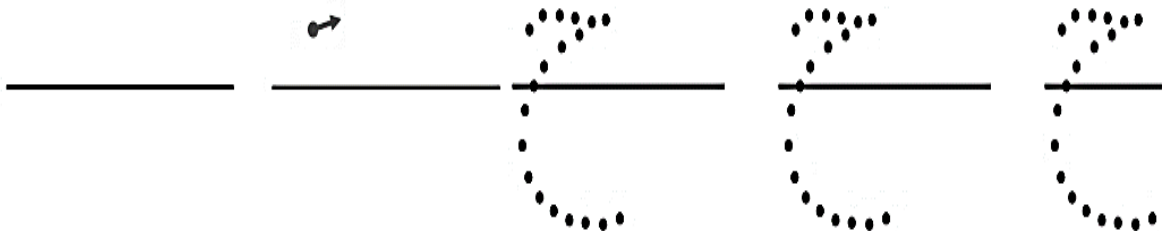
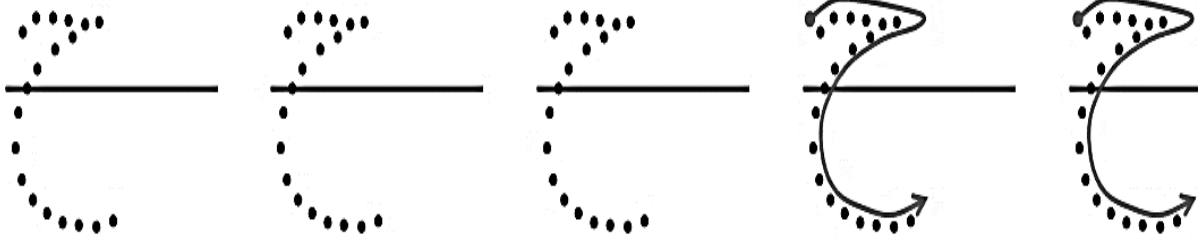

EXERCISE 28: LETTER RECOGNITION

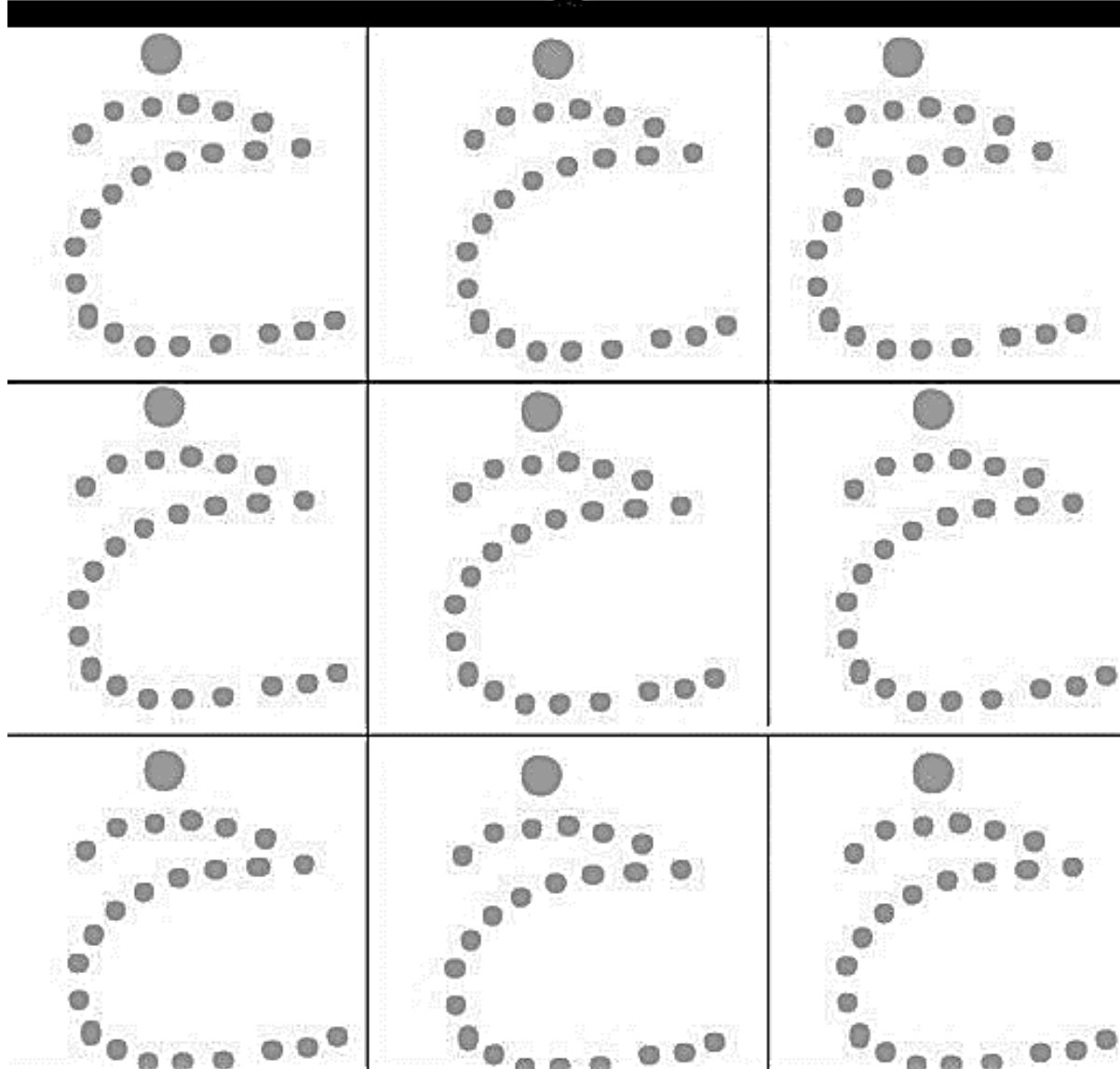
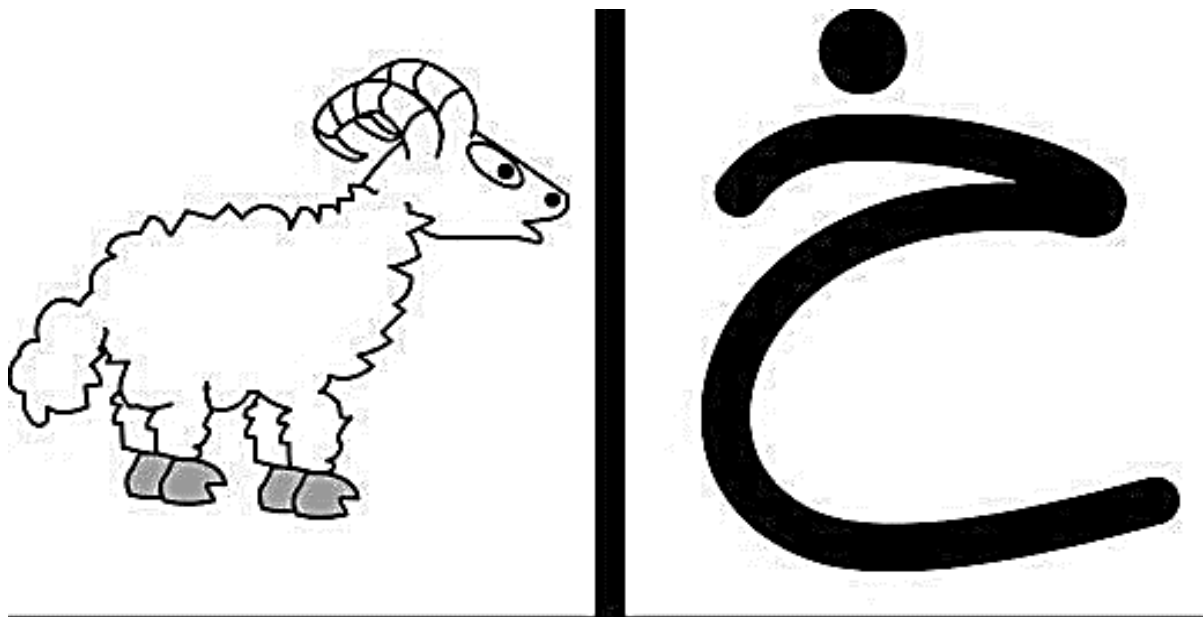

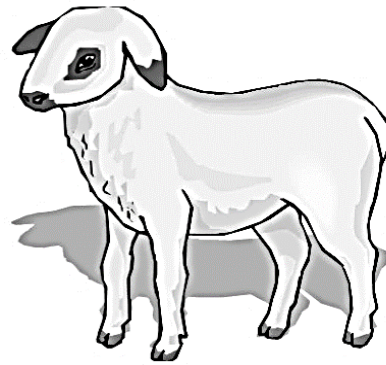
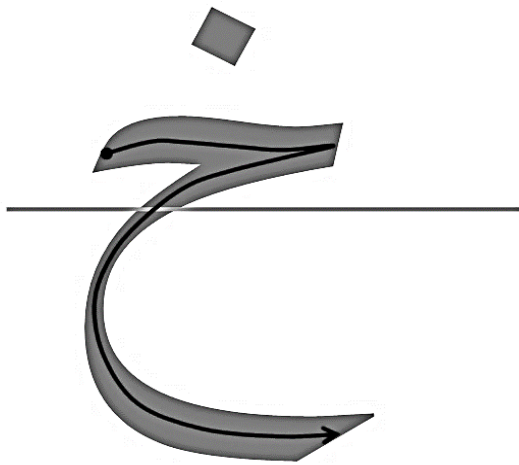
EXERCISE 29: LETTER RECOGNITION

خروف Kharoof

Kha makes the sound 'kha' as in Khadija

Read

خ خ خ خ خ خ

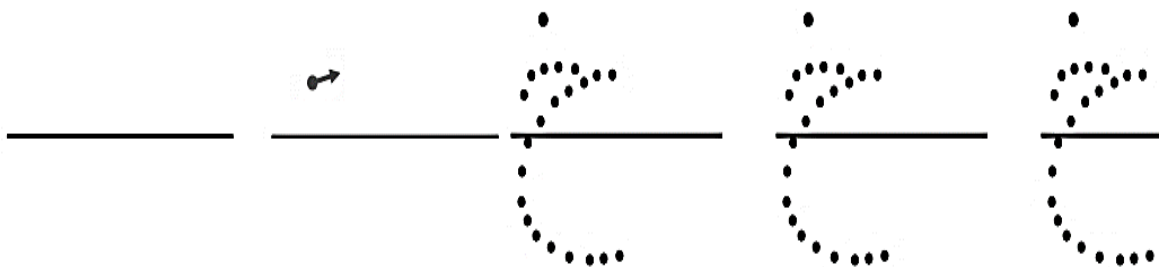
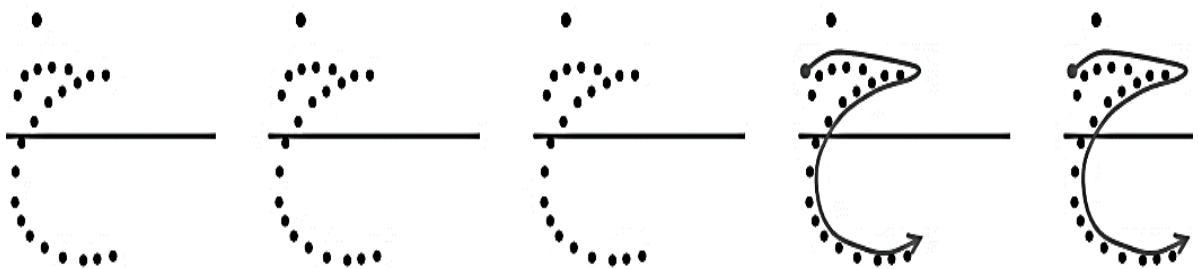

EXERCISE 30: LETTER RECOGNITION

Colour only the shapes which have the letter ج

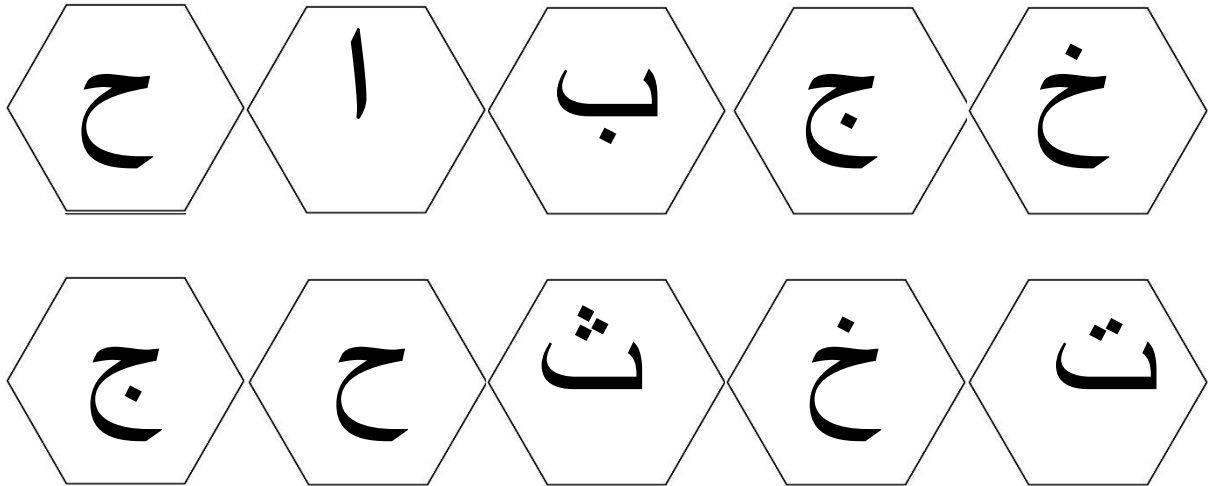
**EXERCISE 31: LETTER RECOGNITION**

Colour only the shapes which have the letter ح

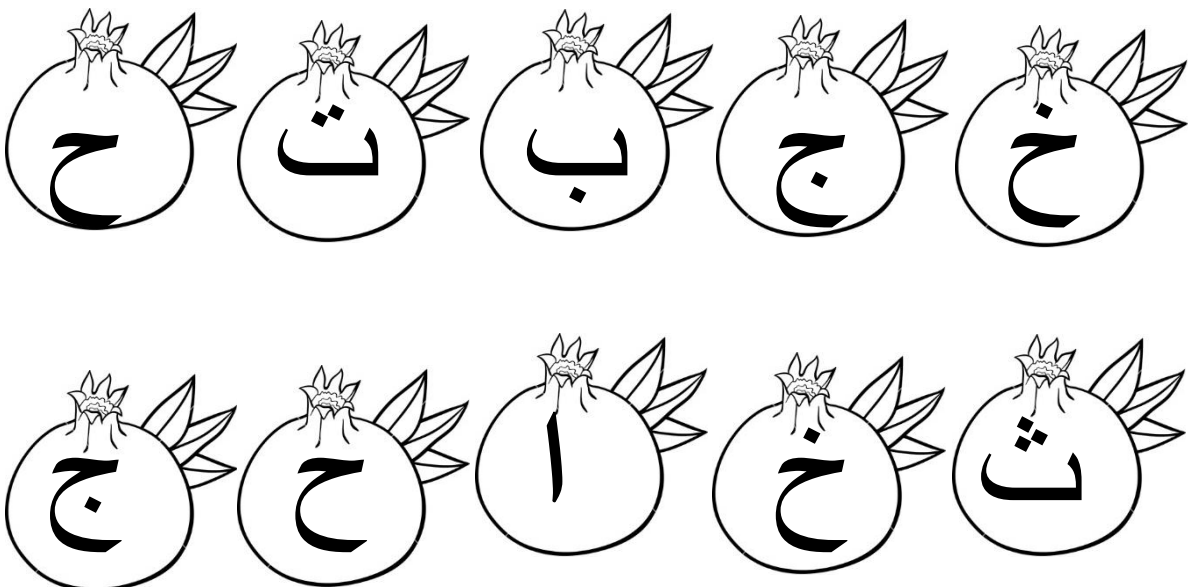

EXERCISE 32: LETTER RECOGNITION

Colour only the ball which has the letter ج ج

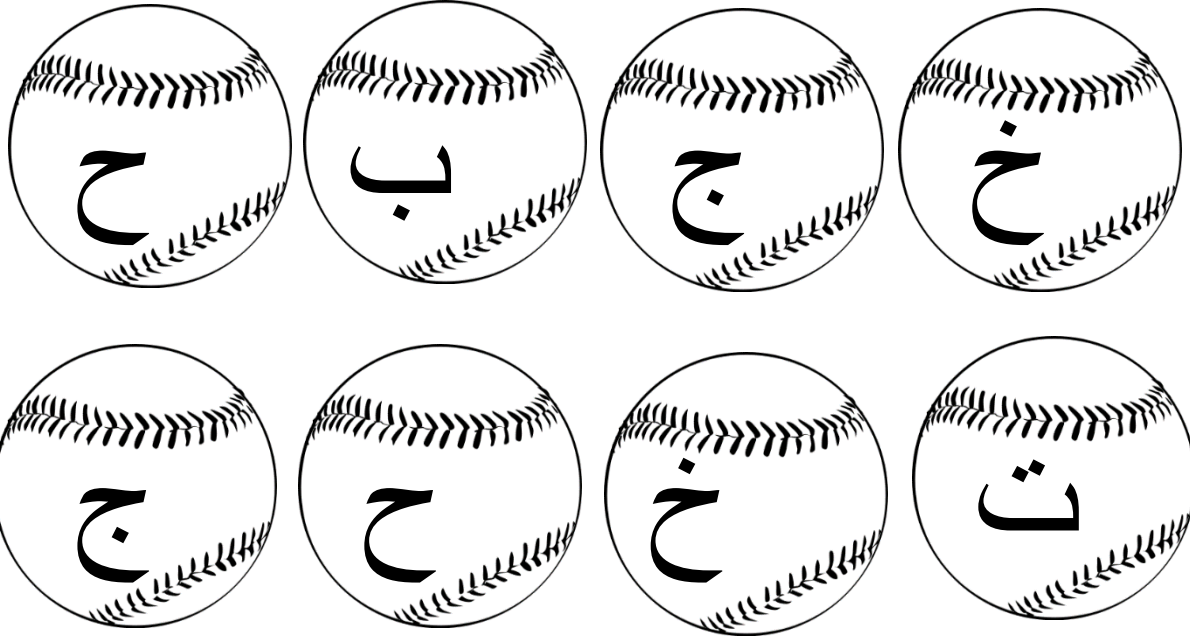

EXERCISE 33: JOINING EXERCISE

RECOGNISING LETTERS ج TO خ

Draw lines to match the same letters

خ	ح		ح	ج
ج	ج		ج	ح
ح	خ		خ	خ

EXERCISE 34: COLOURING EXERCISE**RECOGNISING LETTERS ج TO خ**

Colour the Mosque below according to the letters.

خ	ح	ج
Yellow	Blue	Green

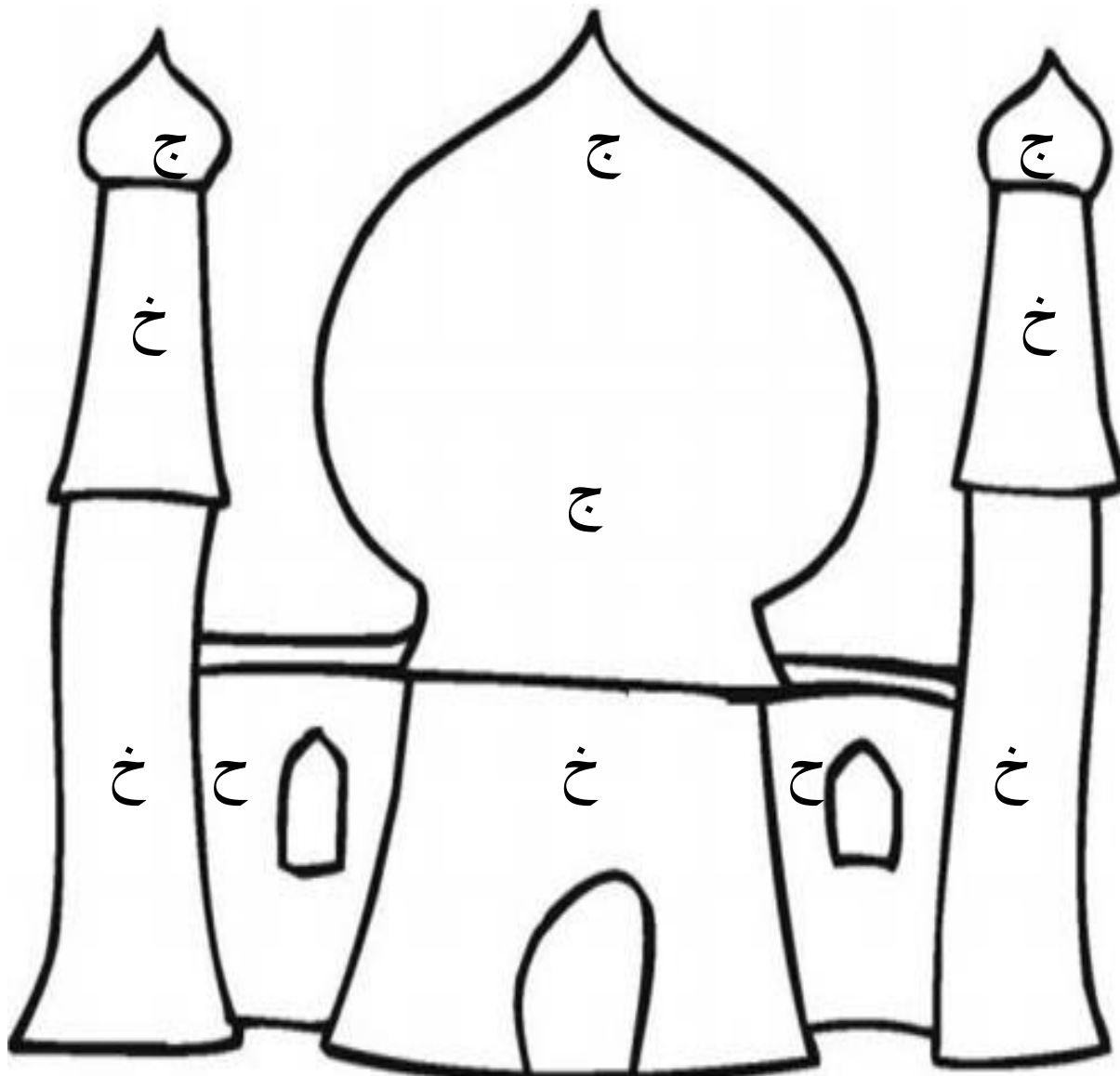

EXERCISE 35: READING EXERCISE**RECOGNISING LETTERS خ TO ج**

Read and identify the alphabets		
خ	ح	ج
Khai	Hai	Jim
ج ح خ ح ج ج ح		
خ ح ج ج ح خ		
ج ح ب خ ث ث		
خ ح ج ث ث خ		

RECOGNISING and WRITING LETTERS خ TO ج

خ	ح	ج
خ	ح	ج

EXERCISE 36: LETTER RECOGNITIONCircle the correct matching letter





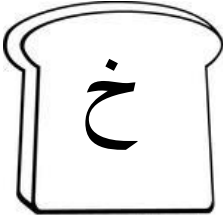
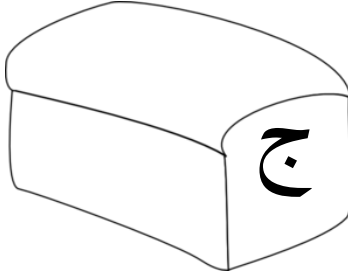
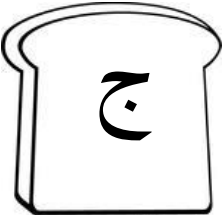
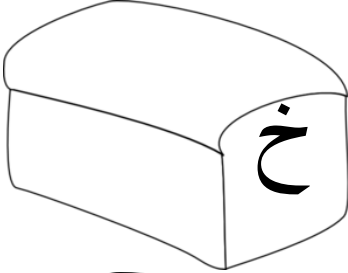
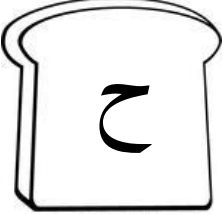
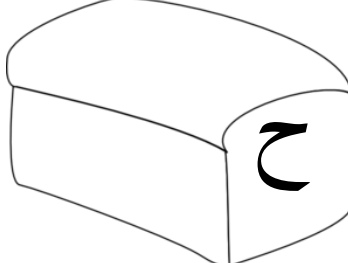

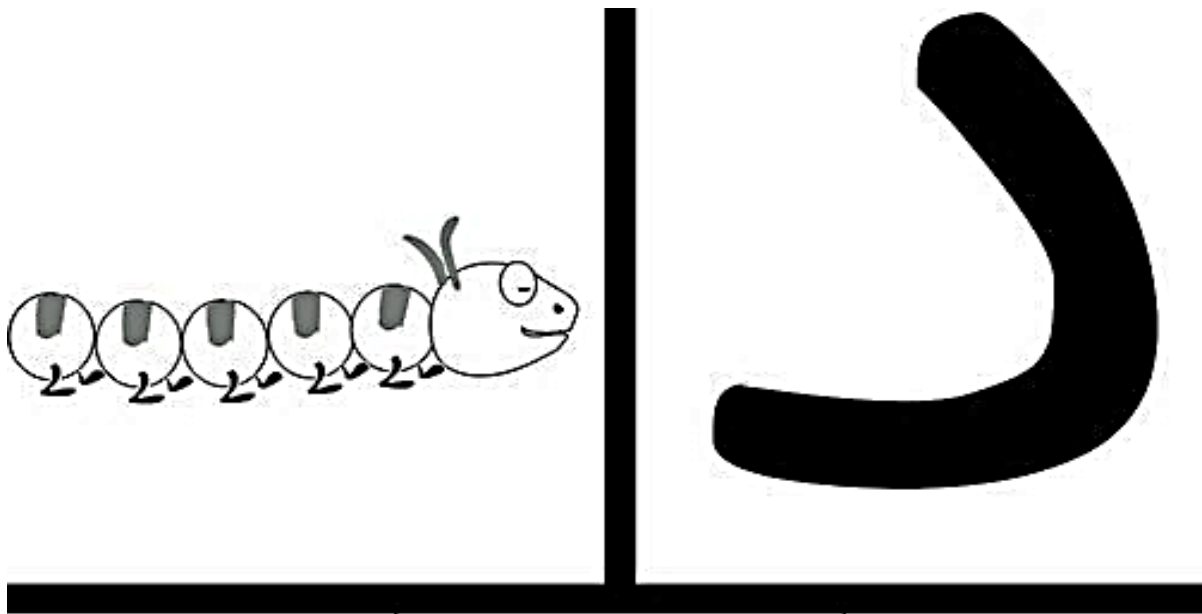

ج	=	ب	خ	ج	ث	ا	ج
ح	=	خ	ح	ث	ج	ح	ا
خ	=	ا	خ	ث	ح	خ	ث

EXERCISE 37: CONNECT THE MATCHING LETTERS

	
	
	

EXERCISE 38: LETTER RECOGNITION



EXERCISE 39: LETTER RECOGNITION

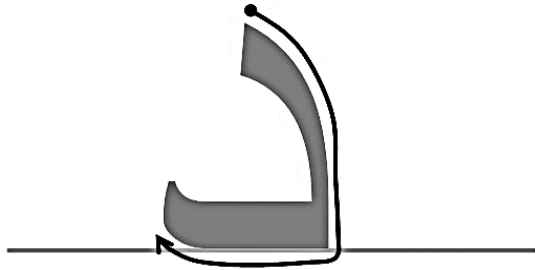

دراجة Darrajah

Dal makes the sound 'da' as in Dawood

Read



EXERCISE 40: LETTER RECOGNITION

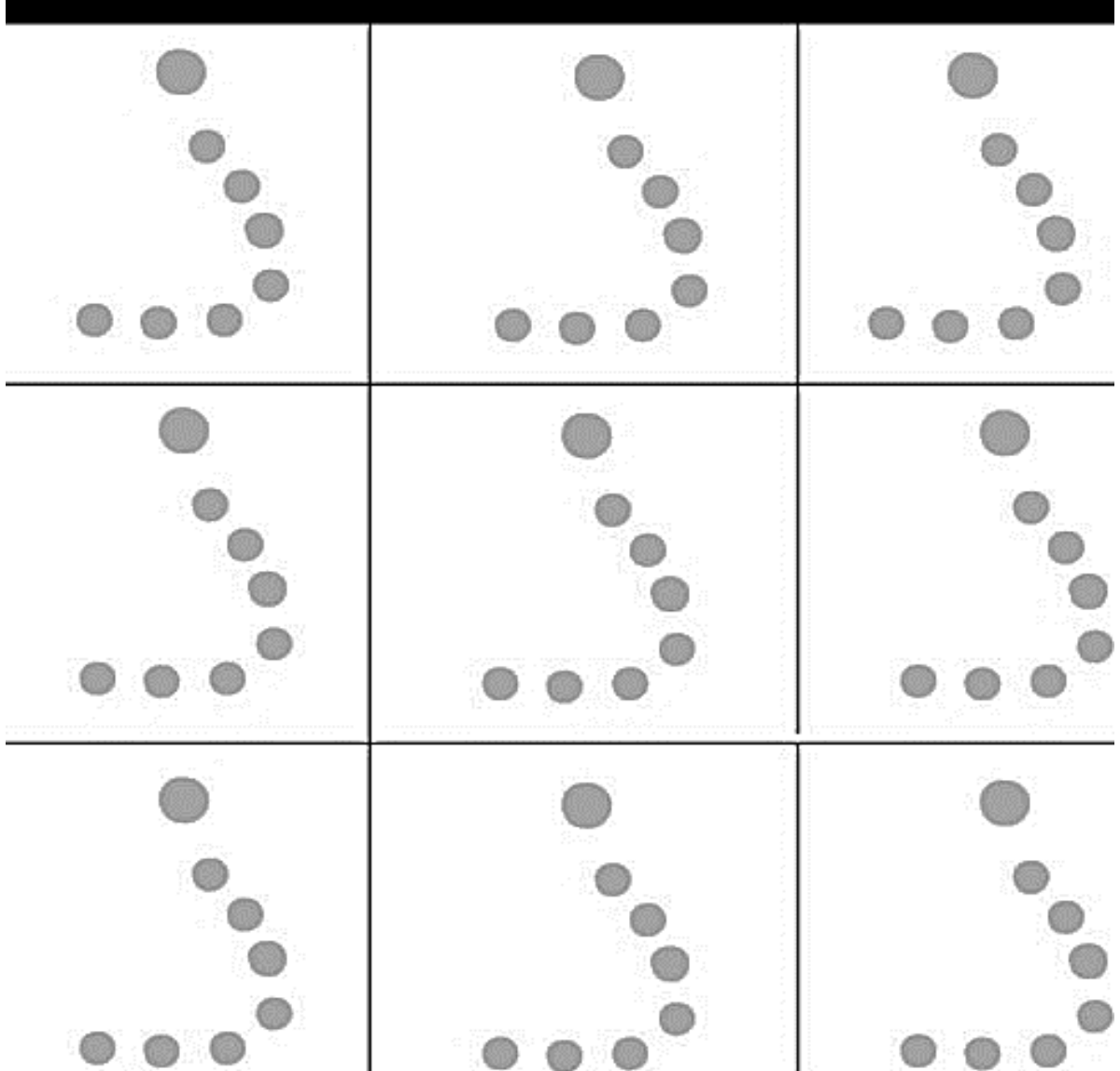
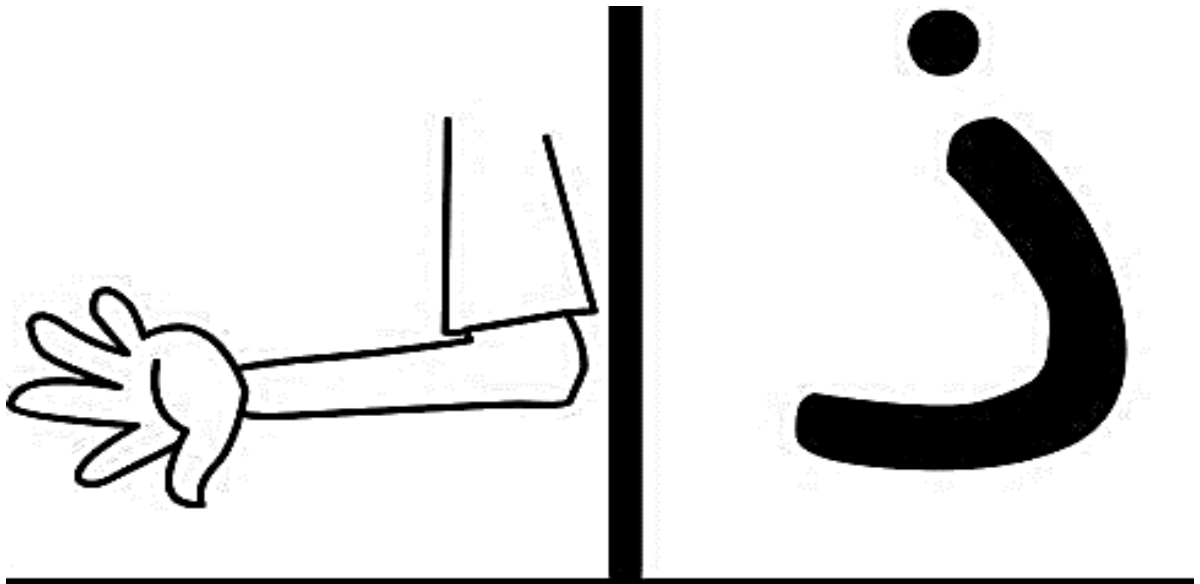

EXERCISE 41: LETTER RECOGNITION

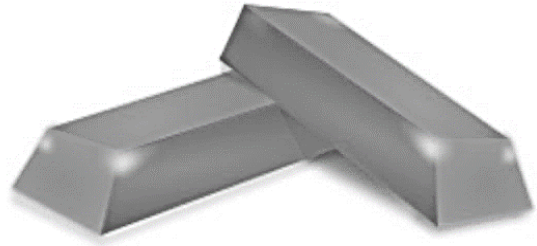
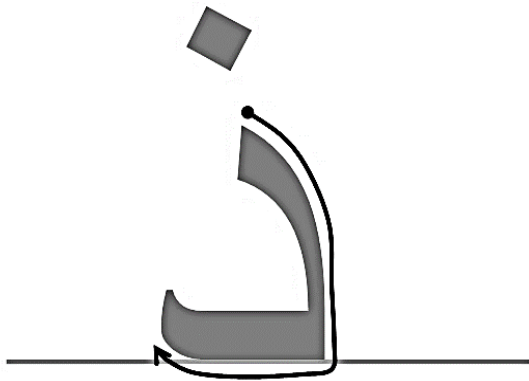

ذهب Dhahab

Dhal makes the sound 'tha' as in That

Read



EXERCISE 42: LETTER RECOGNITION

Colour only the Lolly which has the letter د

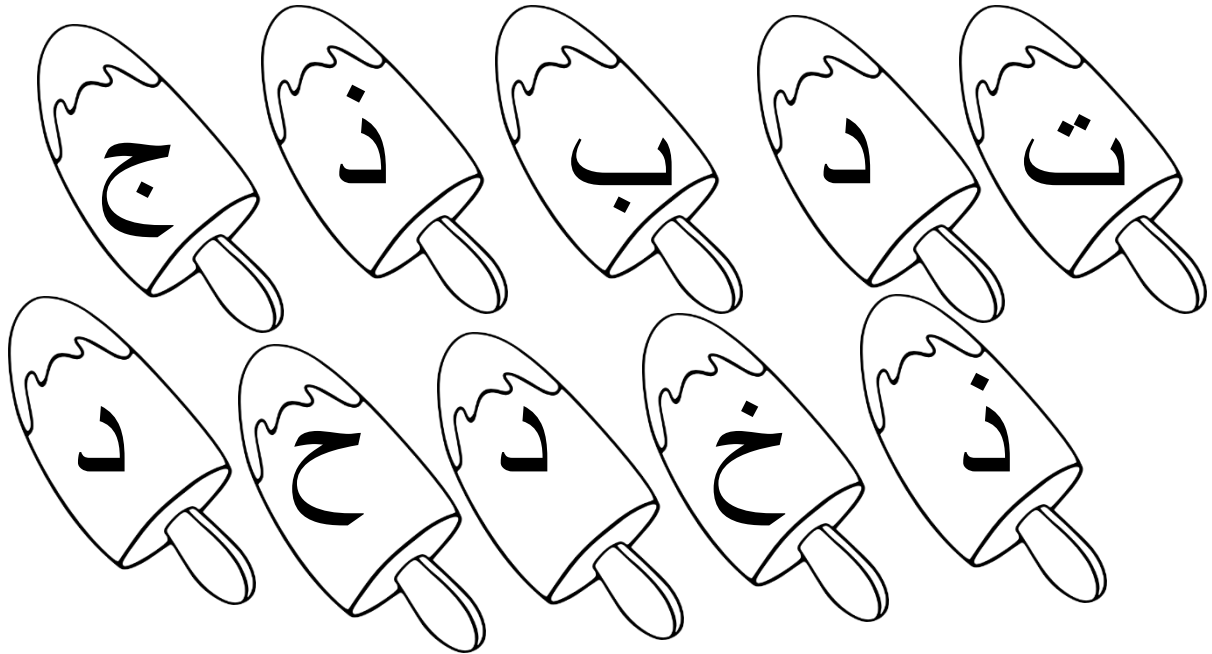
**EXERCISE 43: LETTER RECOGNITION**

Colour only the Nut which has the letter د

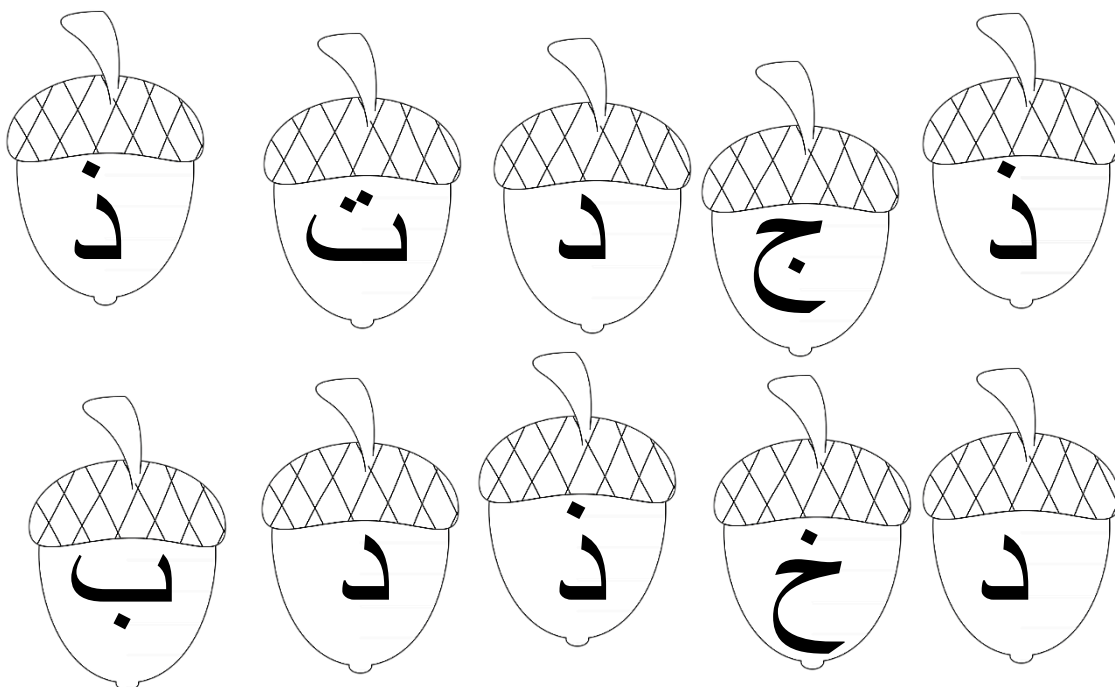

EXERCISE 44: LETTER RECOGNITION

Join the matching letters

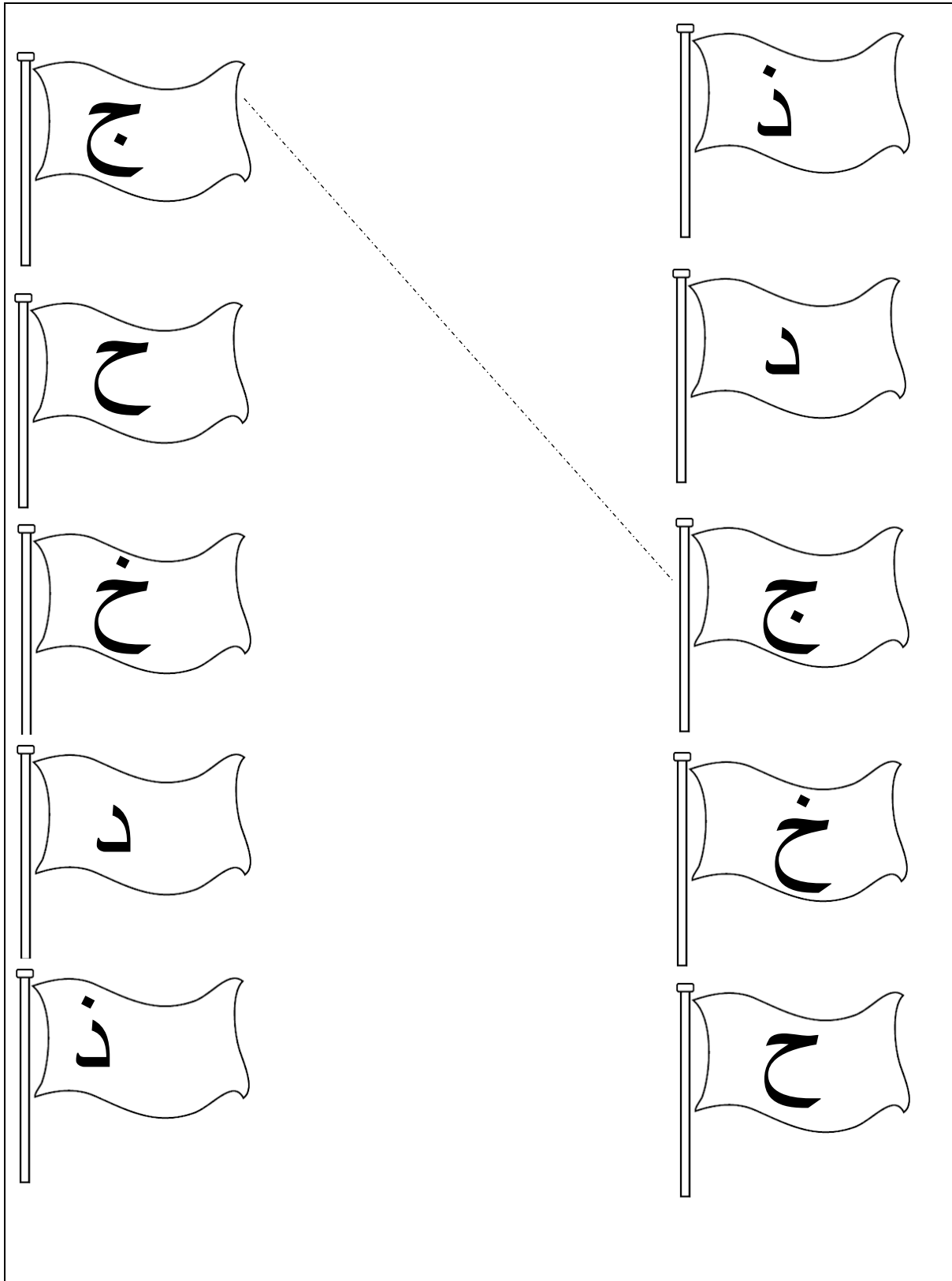

EXERCISE 45: READING EXERCISE**RECOGNISING LETTERS ذ TO د**

Read and identify the alphabets	
ذ	د
Dhal	Dal
د ذ د ذ د ذ د ذ	
ذ ذ ذ ذ ذ ذ ذ ذ	
ذ ذ ذ ذ ذ ذ ذ ذ	
ذ ذ ذ ذ ذ ذ ذ ذ	

RECOGNISING and WRITING LETTERS ذ TO د

ذ	د
ذ	د

EXERCISE 46: JOINING EXERCISE**RECOGNISING LETTERS د TO ذ**

Join the eggs with the same letters

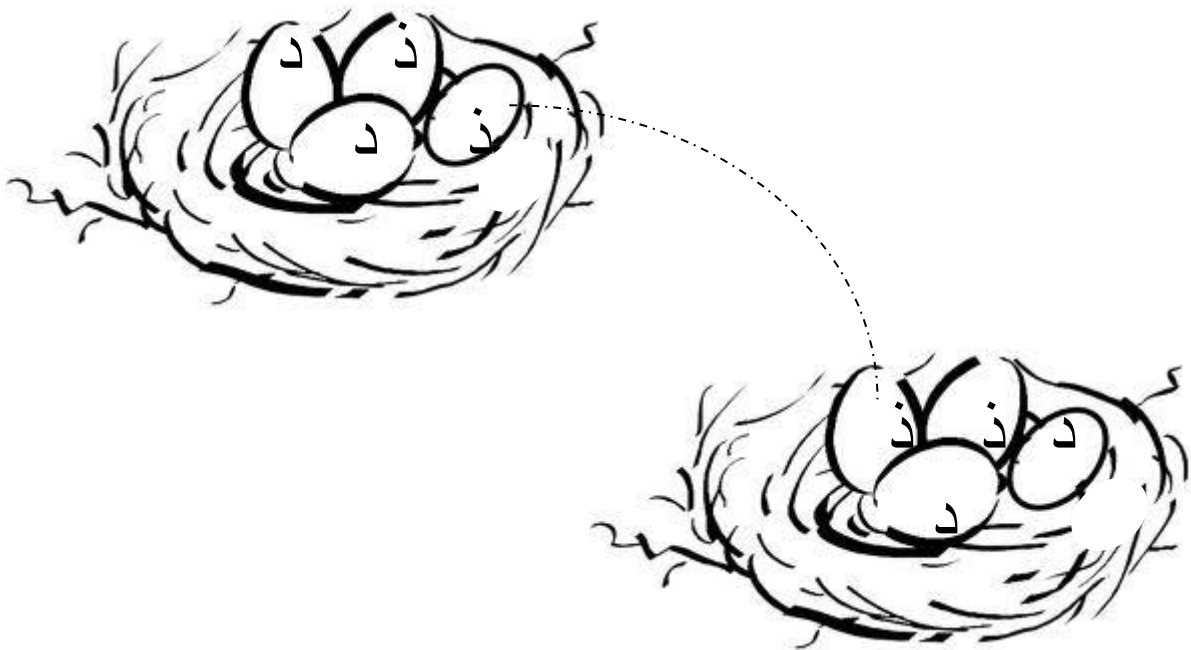
**EXERCISE 47: COLOURING EXERCISE****RECOGNISING LETTERS د TO ذ**

Colour the boxes with د Orange and boxes with ذ Yellow

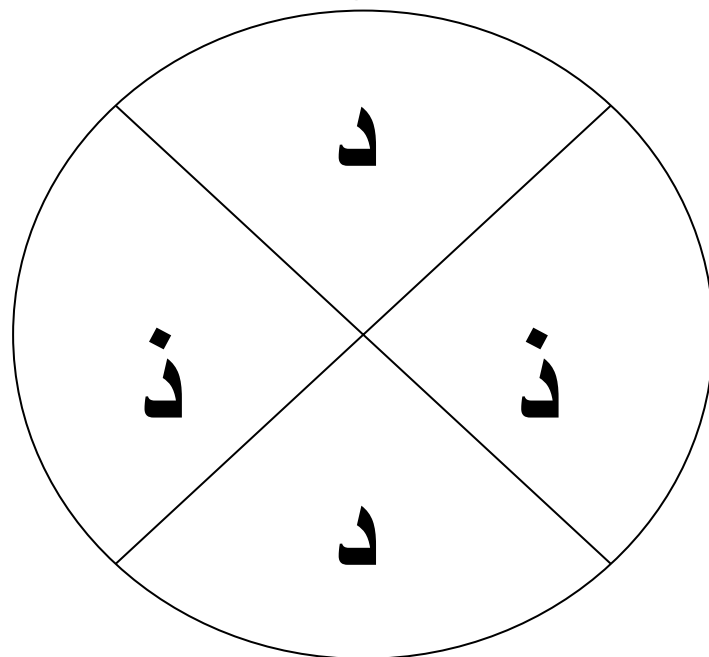

EXERCISE 48: LETTER RECOGNITION

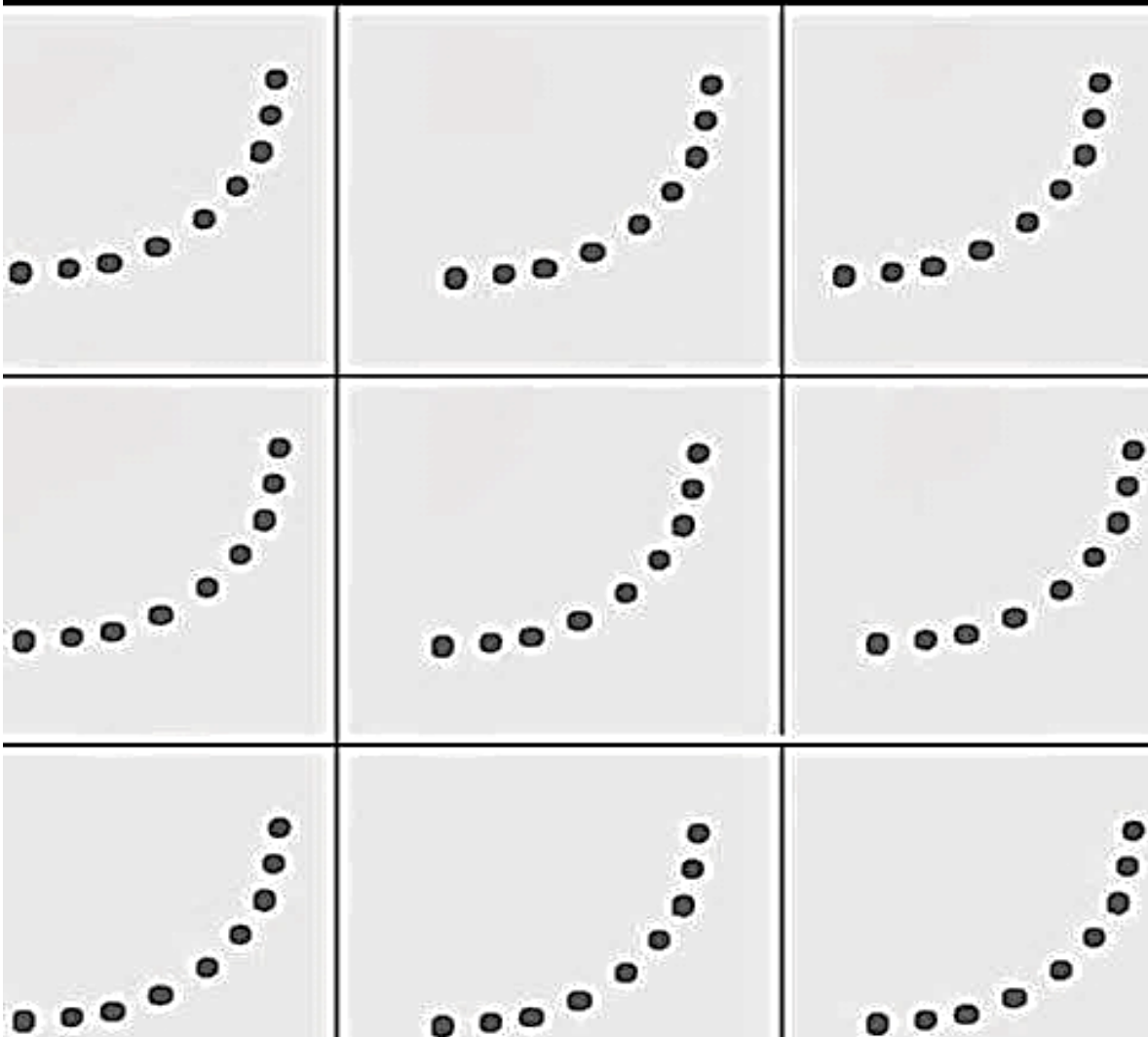
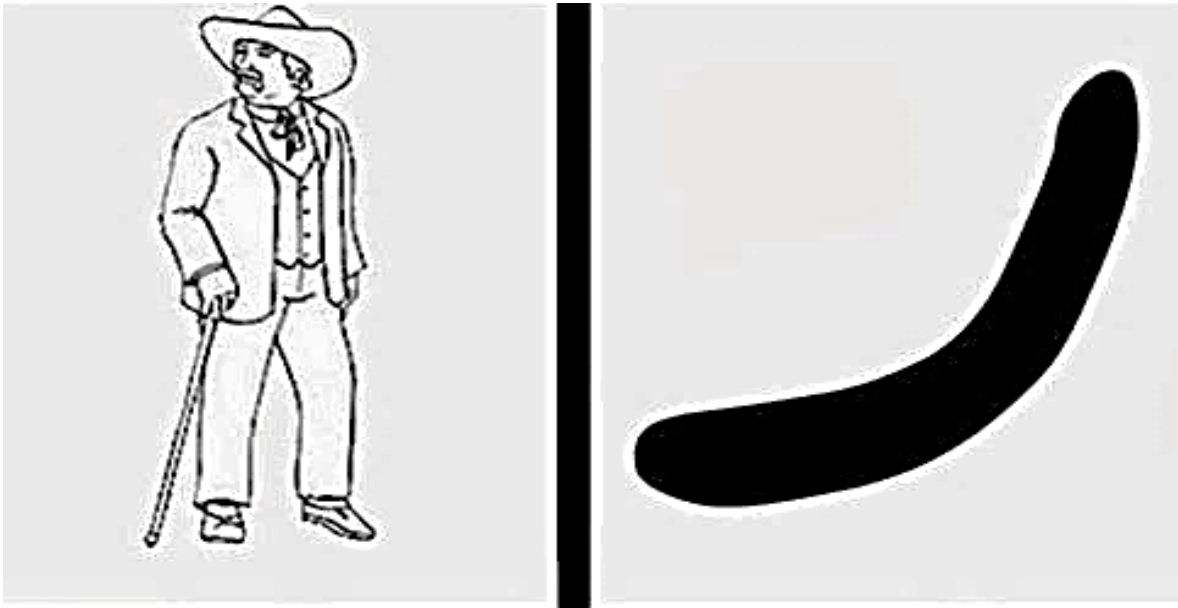

EXERCISE 49: LETTER RECOGNITION

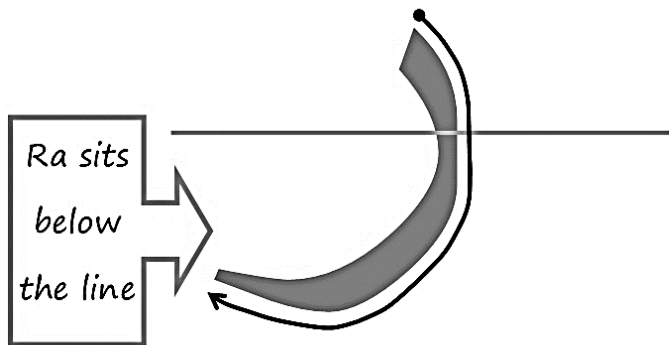

رَسَّام Rassaam

Ra makes the sound 'ra' as in Rat

Read

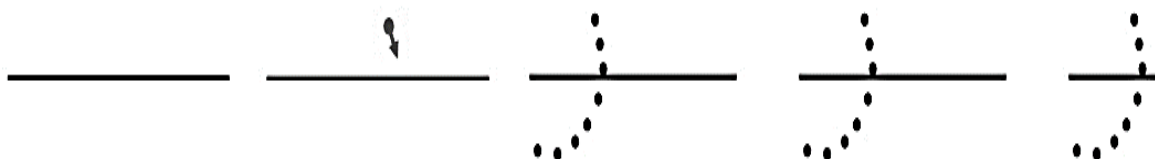
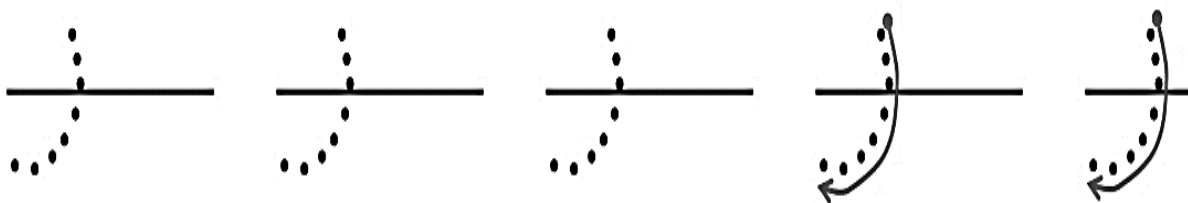

EXERCISE 50: LETTER RECOGNITION

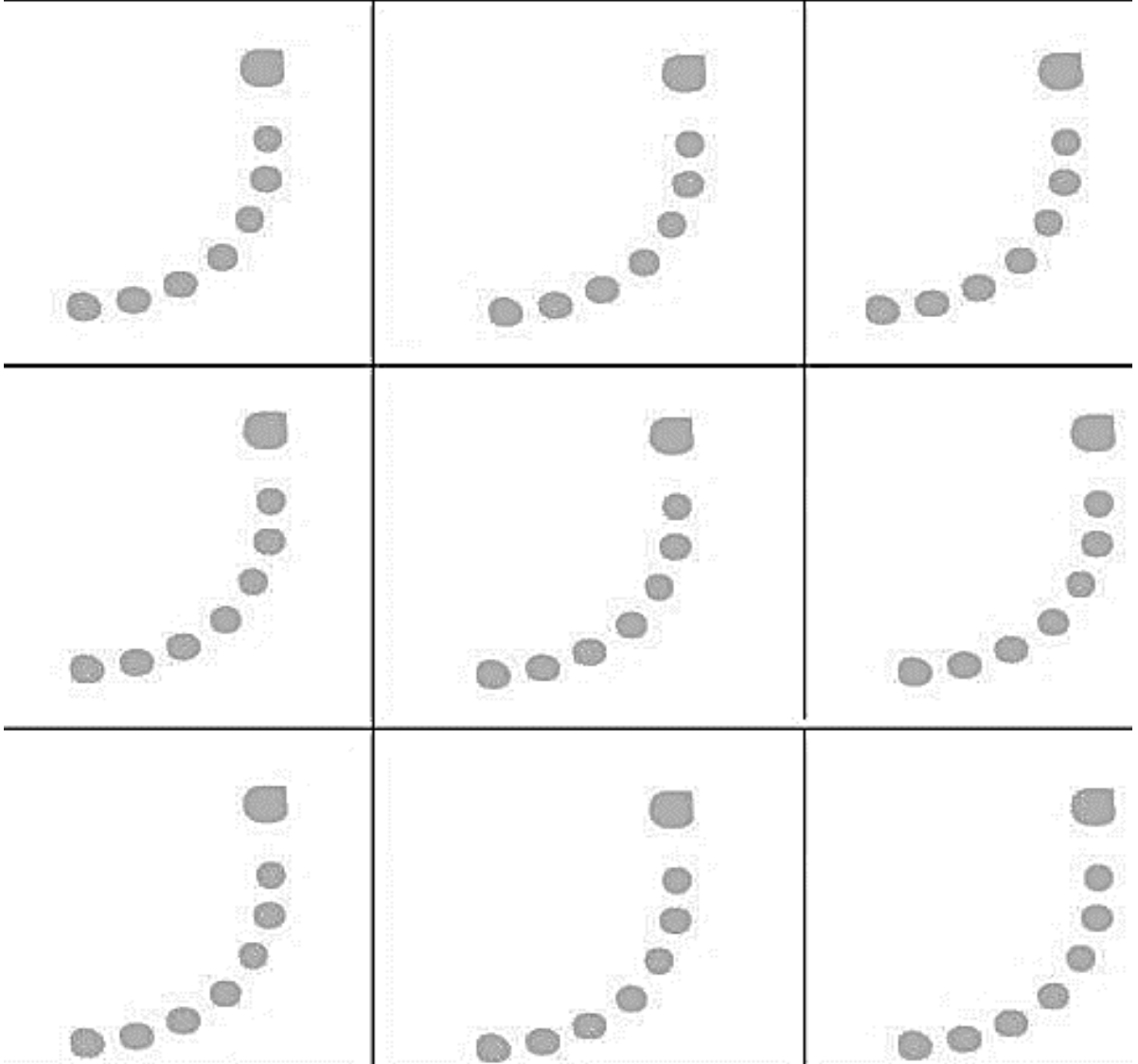
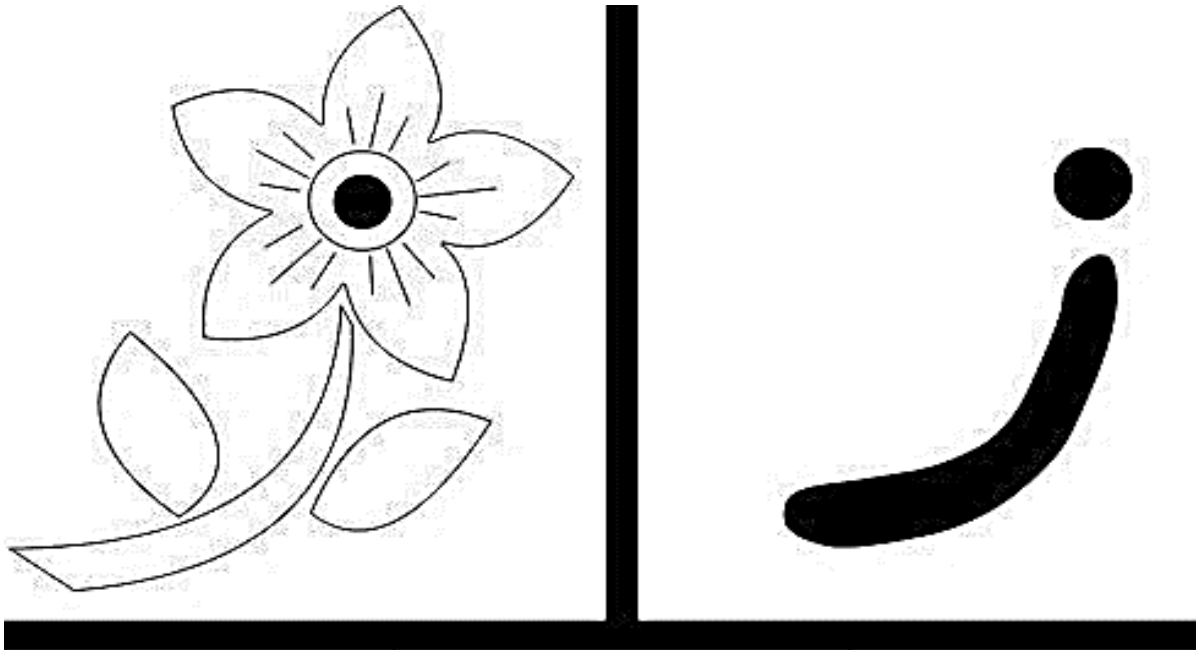

EXERCISE 51: LETTER RECOGNITION

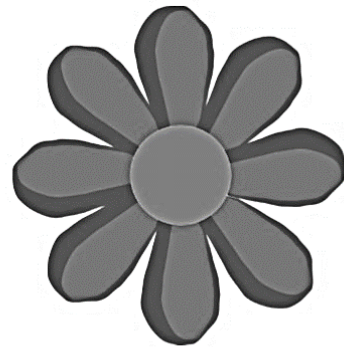
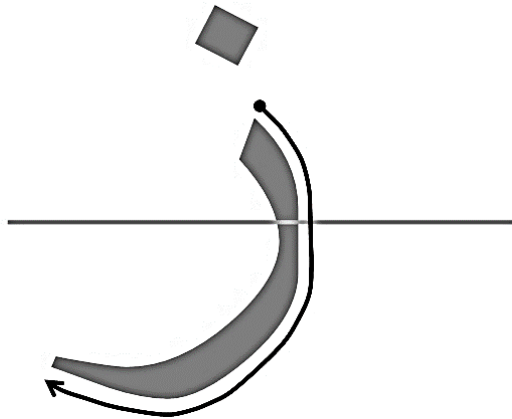

زهرة Zahra

Za makes the sound 'za' as in Zakariya

Read

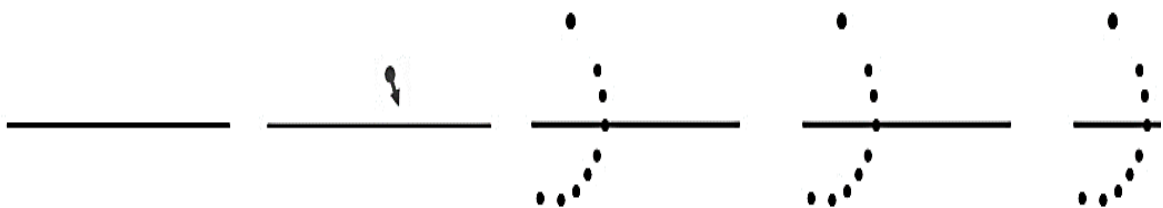
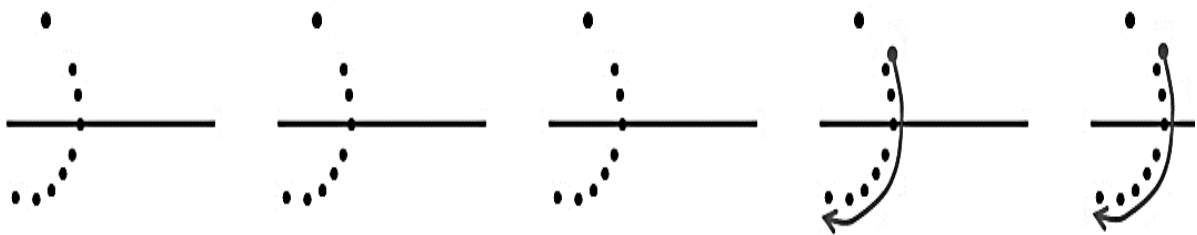

EXERCISE 52: LETTER RECOGNITION

Colour only the Shapes which have the letter ر

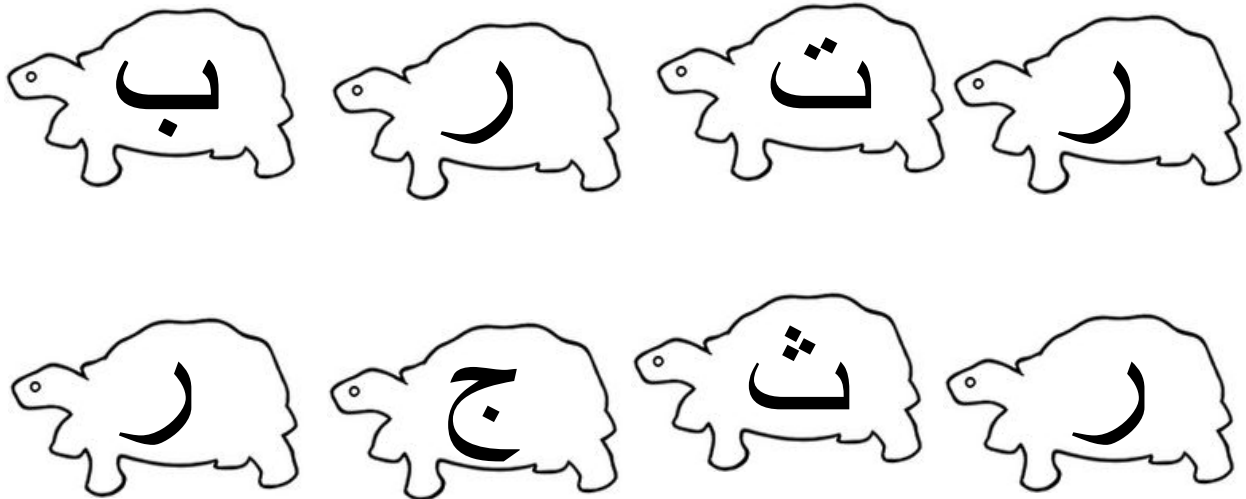
EXERCISE 53: LETTER RECOGNITION

Colour only the shapes which have the letter ز

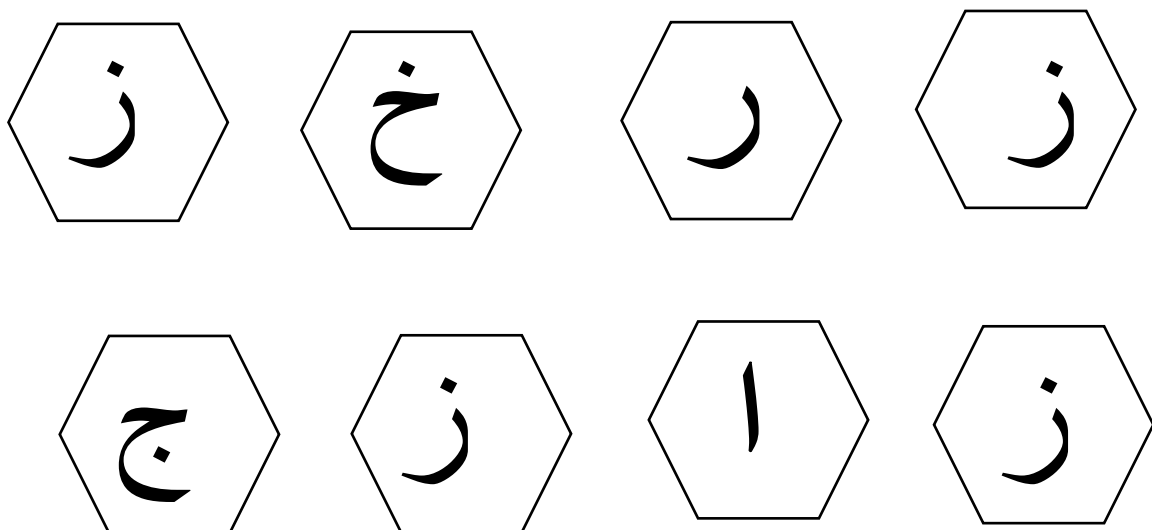

EXERCISE 54: LETTER RECOGNITION

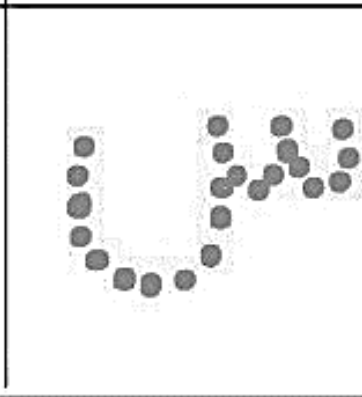
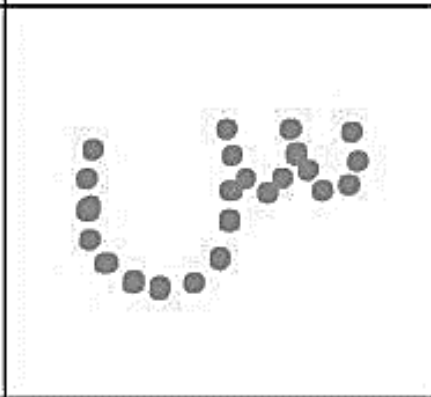
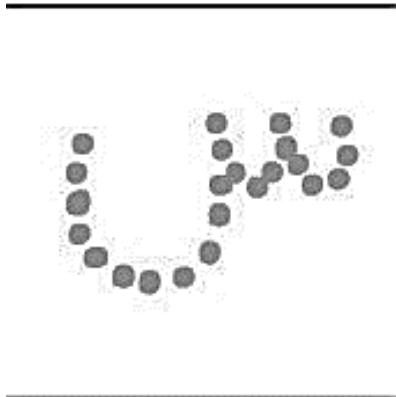
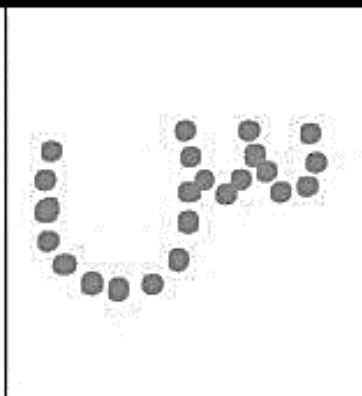
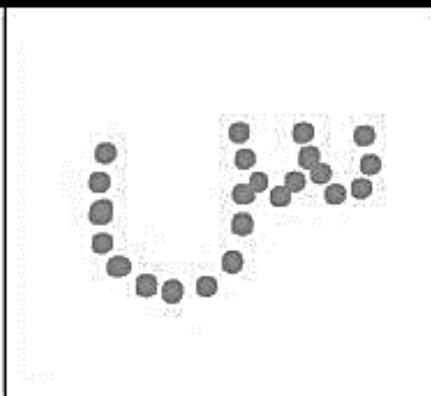
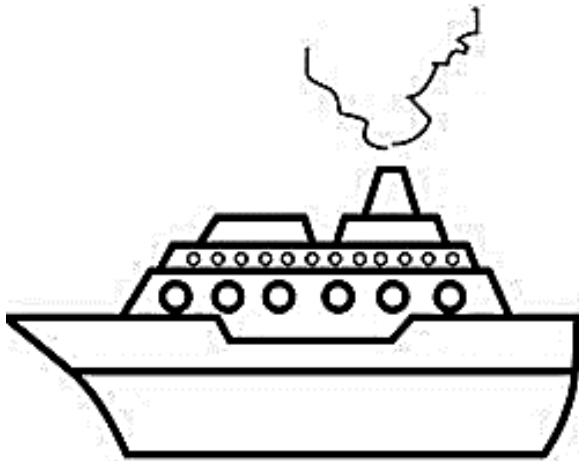

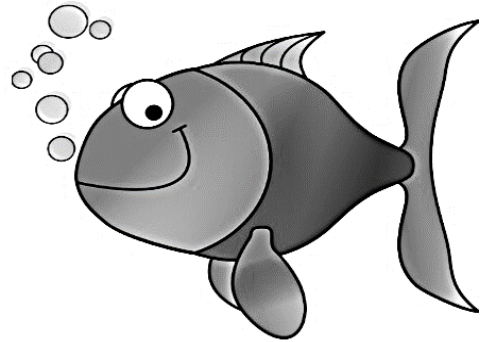
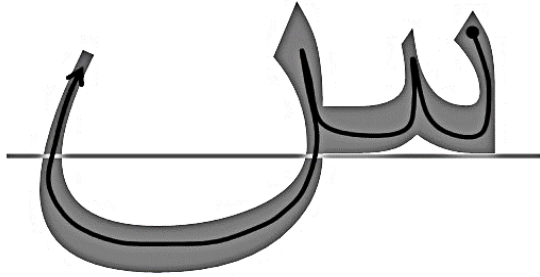
EXERCISE 55: LETTER RECOGNITION

سمكة Samaka

Seen makes the sound 'sa' as in sand

Read

س س س س س

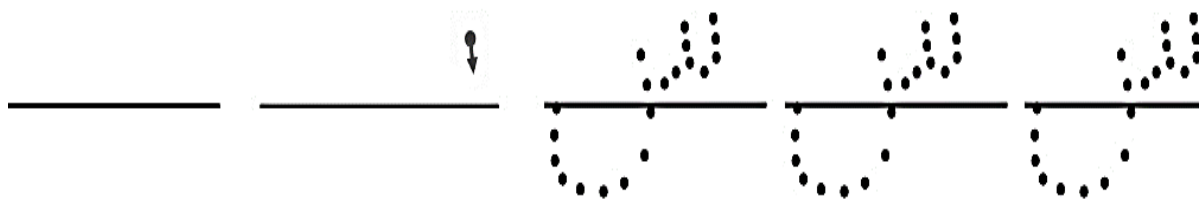

EXERCISE 56: LETTER RECOGNITION

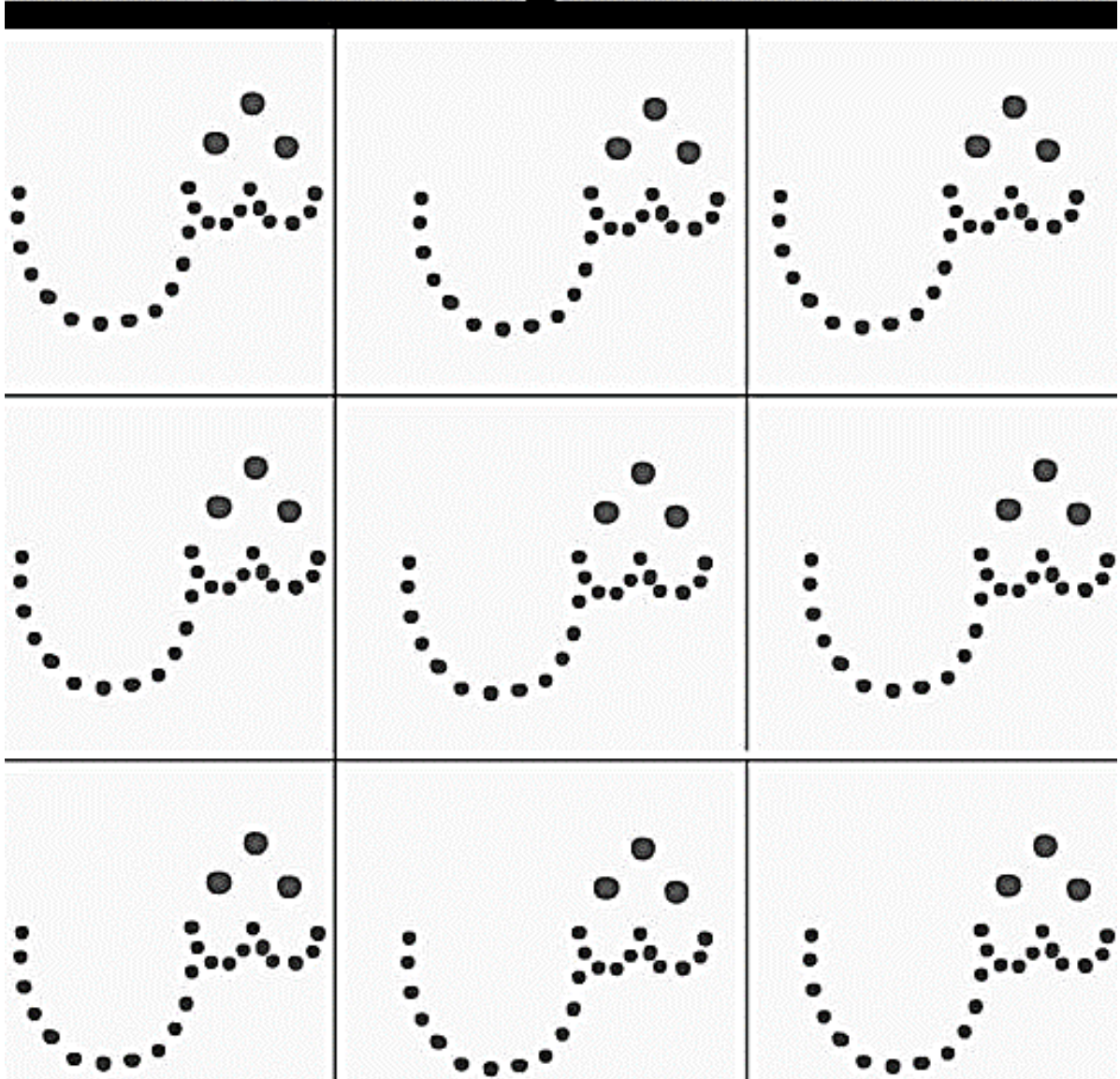
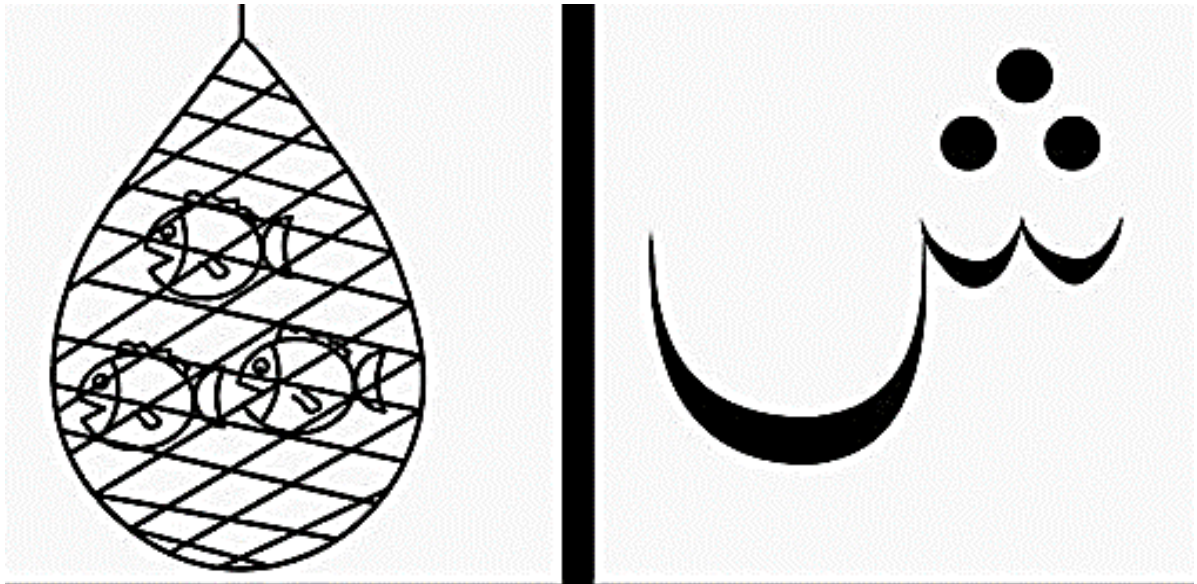

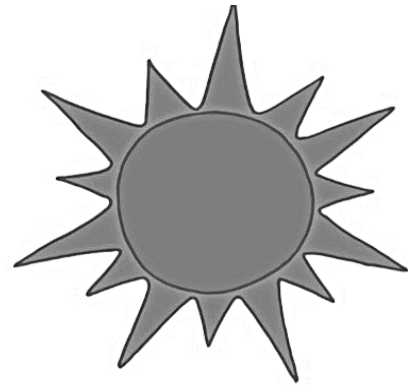
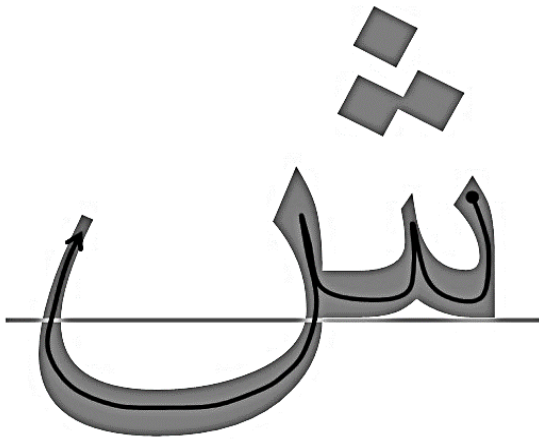
EXERCISE 57: LETTER RECOGNITION

شمس shams

Sheen makes the sound 'sha' as in shark

Read

ش ش ش ش ش

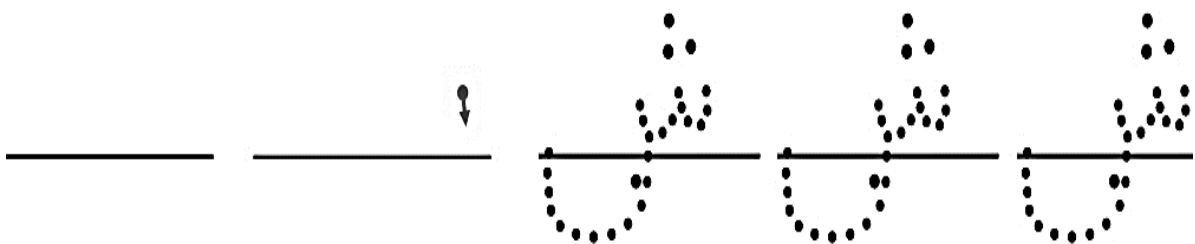
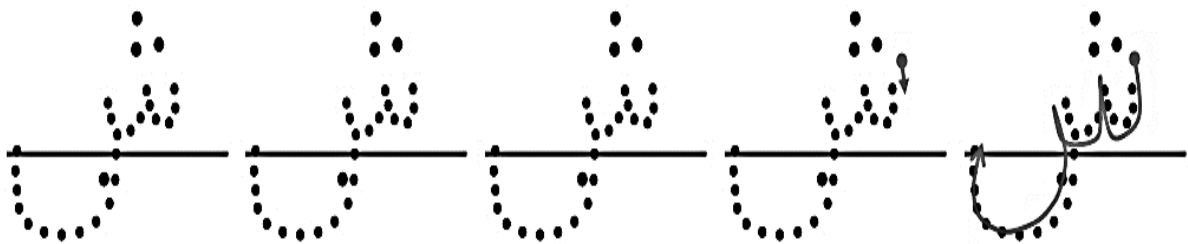

EXERCISE 58: LETTER RECOGNITION

Colour only the shapes which have the letter س

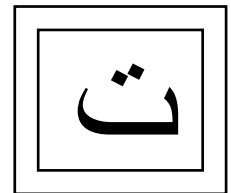
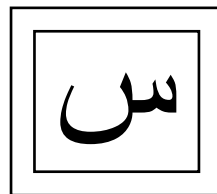
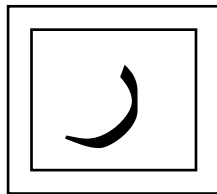
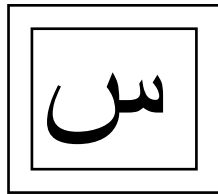
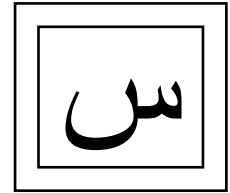
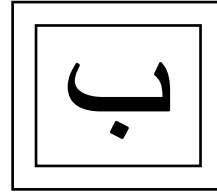
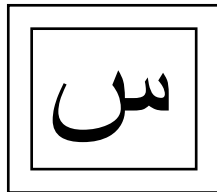
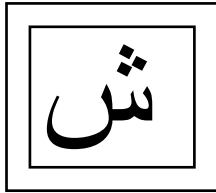
EXERCISE 59: LETTER RECOGNITION

Colour only the shapes which have the letter ش

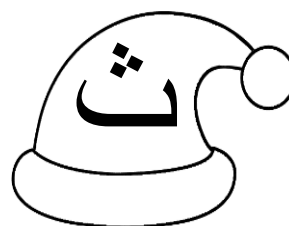
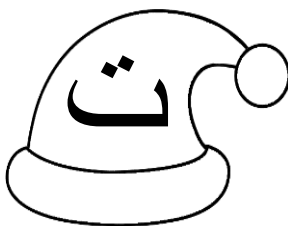
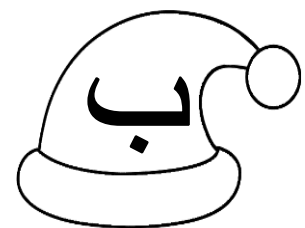
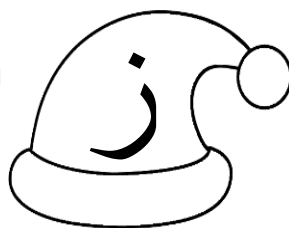
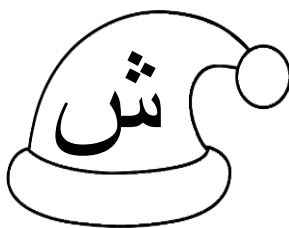

EXERCISE 60: COLOURING EXERCISERECOGNISING LETTERS ر TO ش

Colour the picture below according to the letters.

ز	ر	ش	س
Green	Blue	Yellow	Red

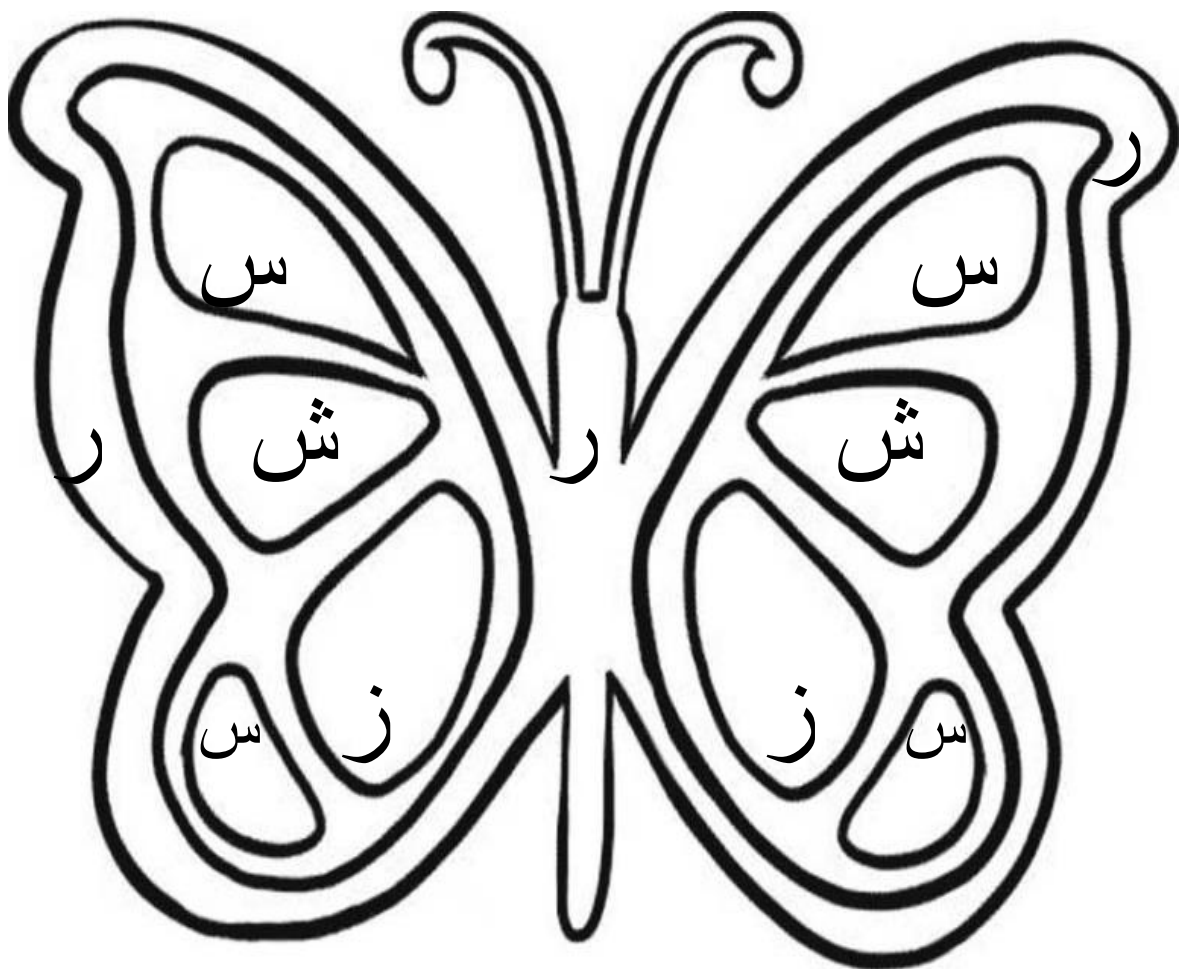

EXERCISE 61: READING EXERCISERECOGNISING LETTERS ر TO ش

Read and identify the alphabets

ش	س	ز	ر
Shin	Sin	Ze	Re
ش	س	ت	ز
ش	س	ر	ب
ش	س	ر	ب
ش	س	ر	ب
ش	س	ر	ب
ش	س	ر	ب

ش	س	ز	ر
ش	س	ز	ر

EXERCISE 62: COLOURING EXERCISERECOGNISING LETTERS ر TO ش





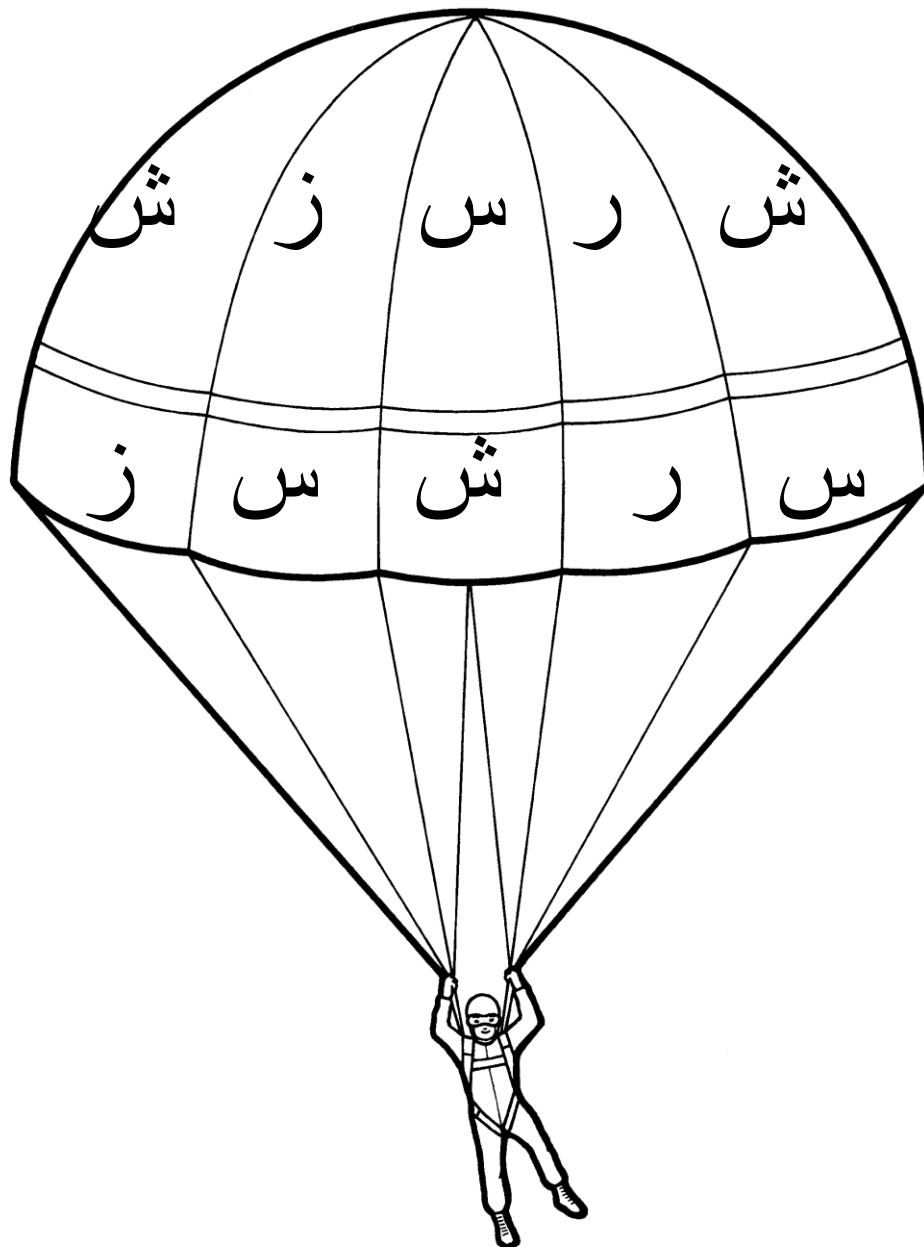

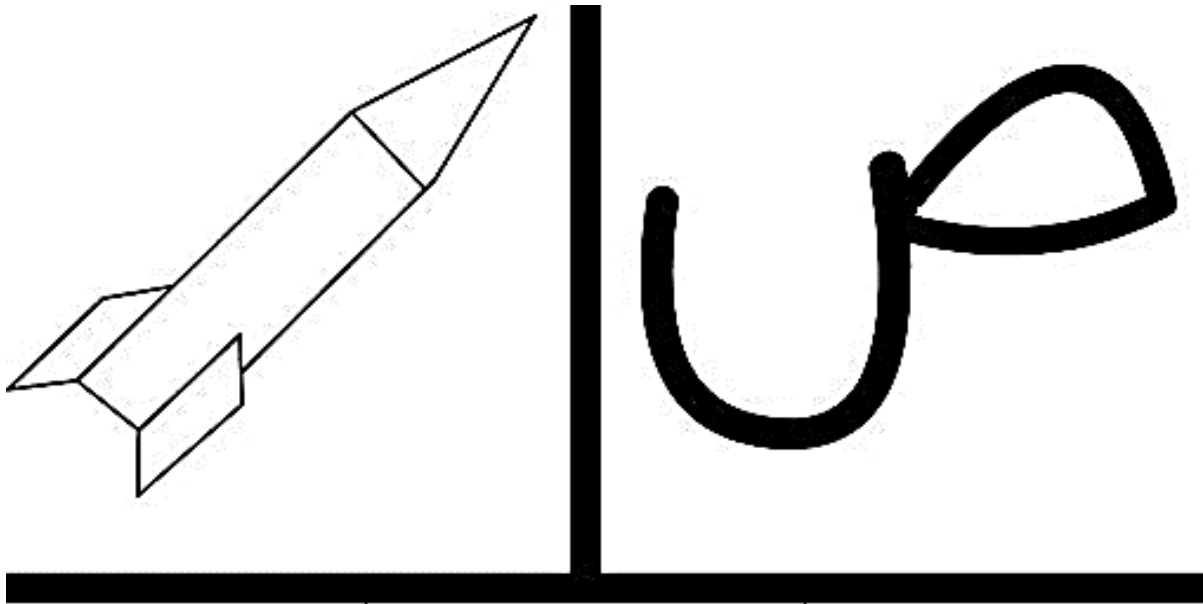

Colour the Parachute below according to the letter.

ش	س	ز	ر
Orange	Yellow	Blue	Green



EXERCISE 63: LETTER RECOGNITION

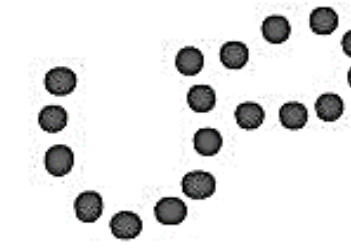

EXERCISE 64: LETTER RECOGNITION

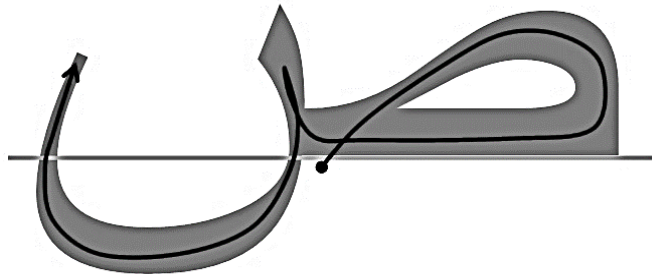
صابون Saaboon

Saad makes the sound 'swa' as in sword





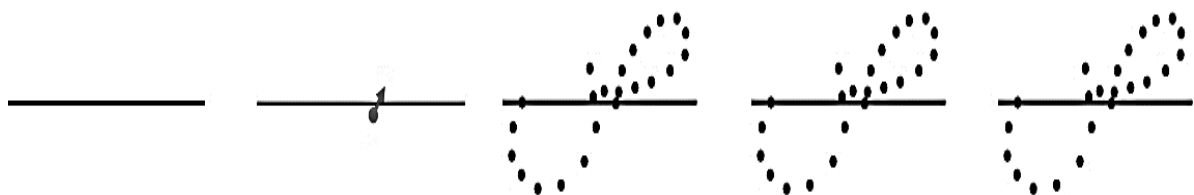
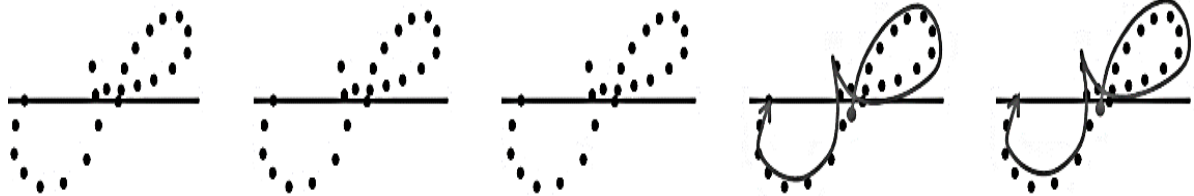

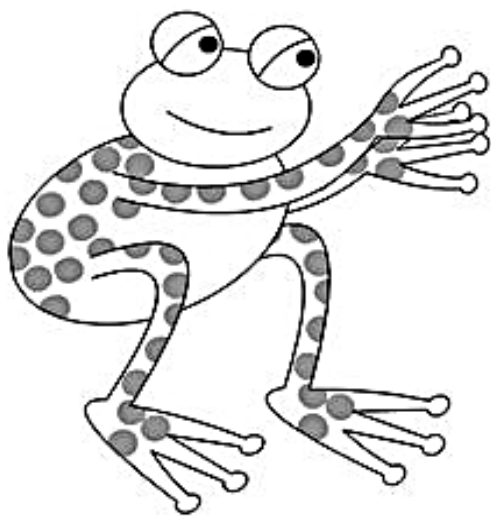

Read

ص ص ص ص



EXERCISE 65: LETTER RECOGNITION

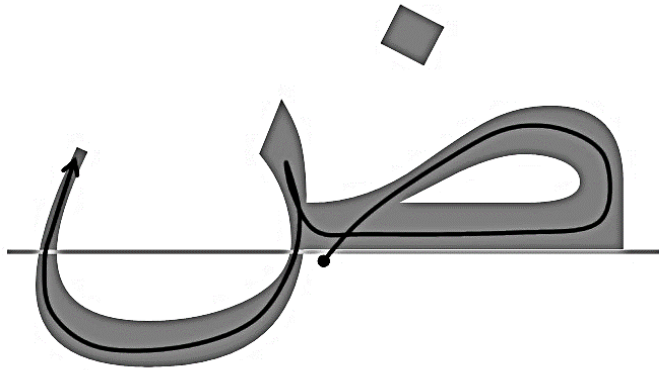

EXERCISE 66: LETTER RECOGNITION

ضفدع Dafda'

Dhaad makes the sound 'dha' as in thou

Read



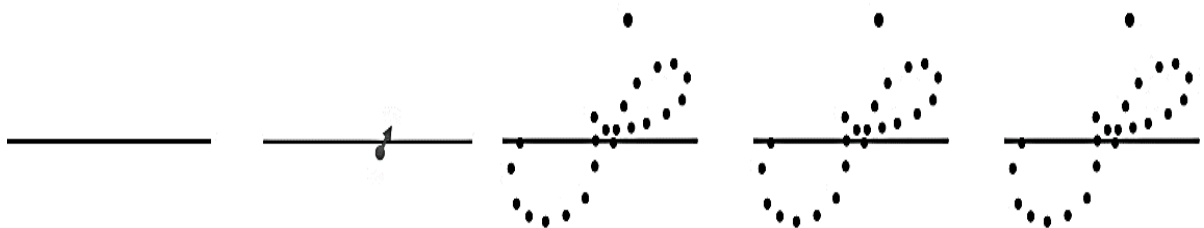
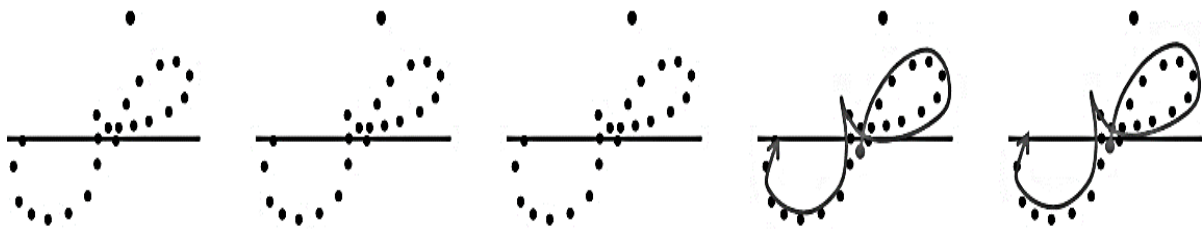

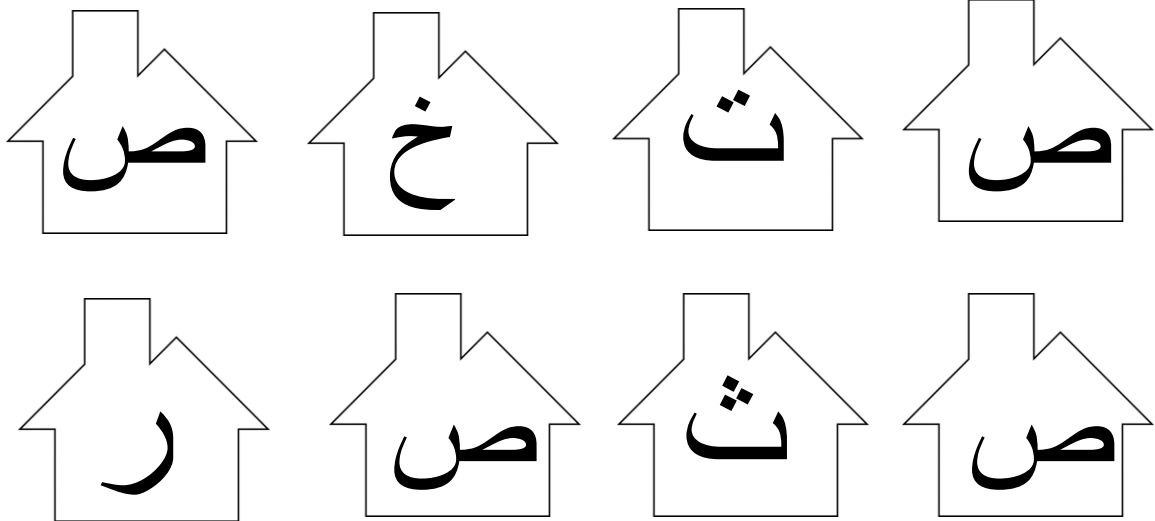
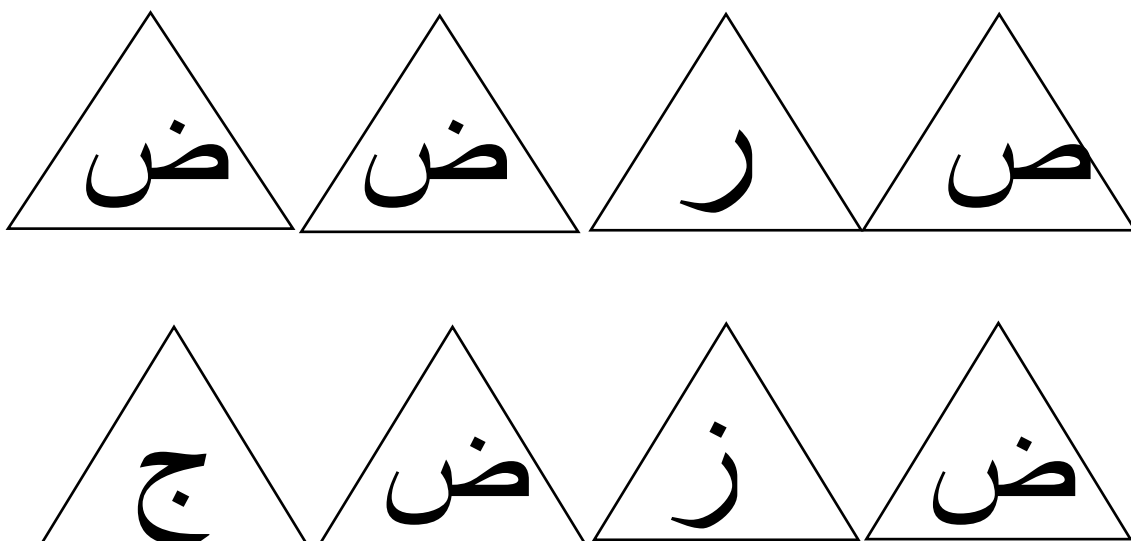

ض ض ض ض

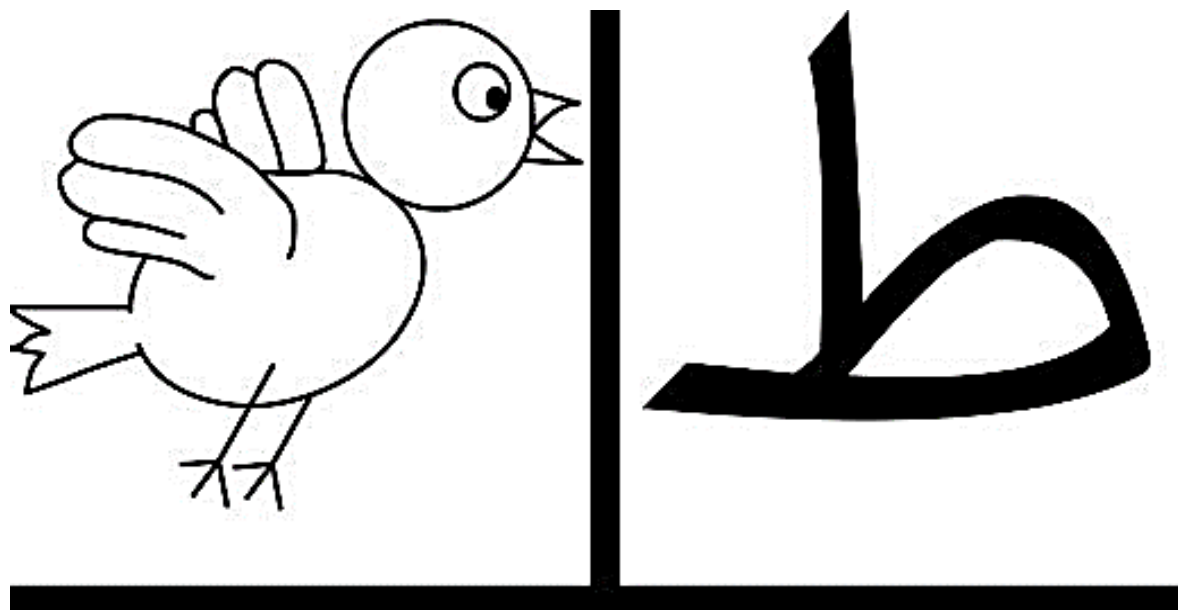

EXERCISE 67: LETTER RECOGNITIONColour only the Shapes which have the letter صEXERCISE 68: LETTER RECOGNITIONColour only the shapes which have the letter ض

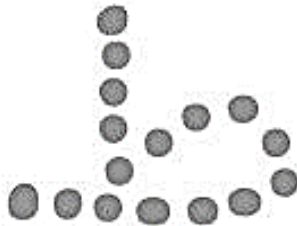
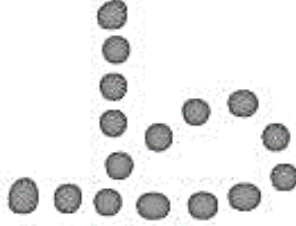
EXERCISE 69: LETTER RECOGNITION

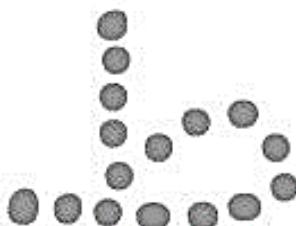

EXERCISE 70: LETTER RECOGNITION

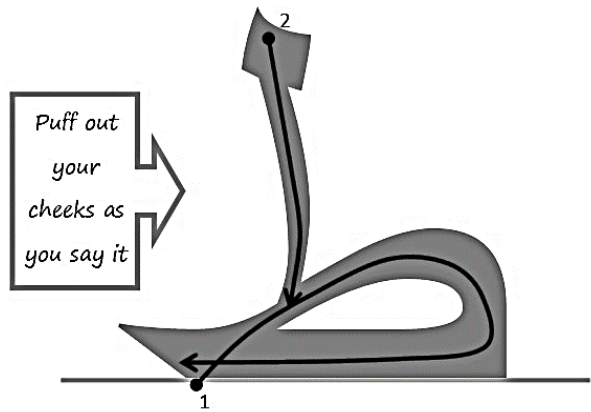

Ta makes the sound 'Ta'





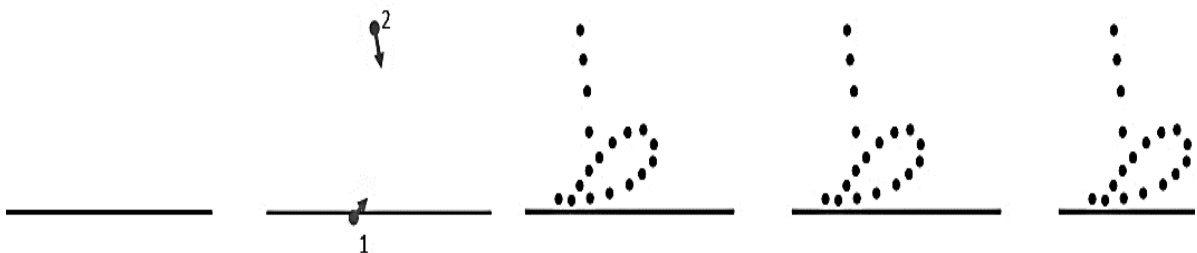

طاووس Tawoos

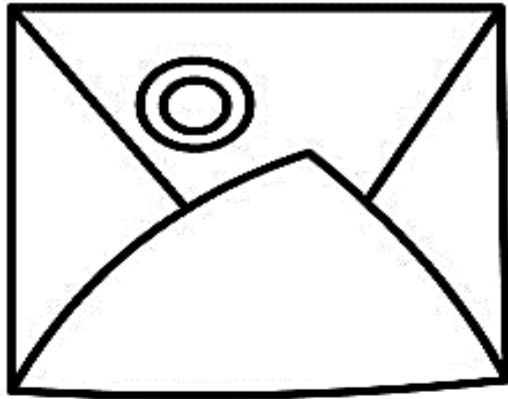
Read

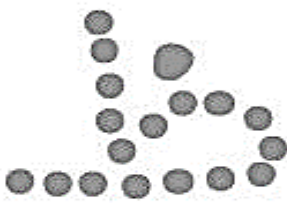
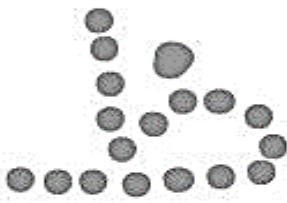

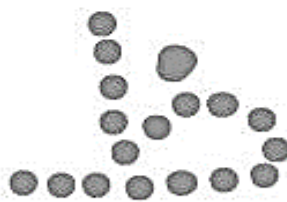
EXERCISE 71: LETTER RECOGNITION



EXERCISE 72: LETTER RECOGNITION

Join the dots and write the letter.

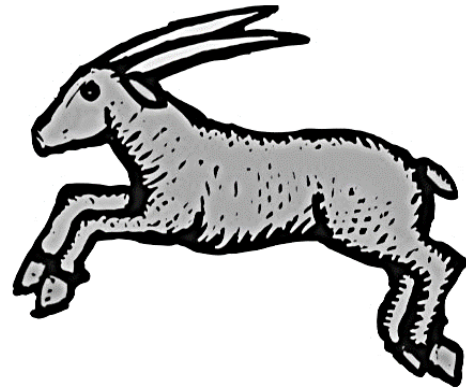
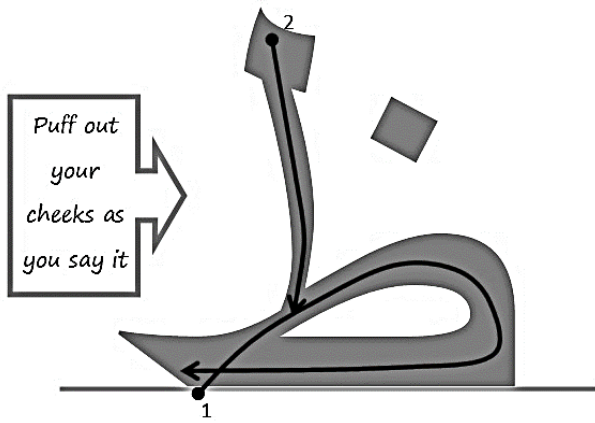

Dha makes the sound 'Dha'

ظبي Dhabi

Read



Write



EXERCISE 73: LETTER RECOGNITION

Colour only the Shapes which have the letter ط

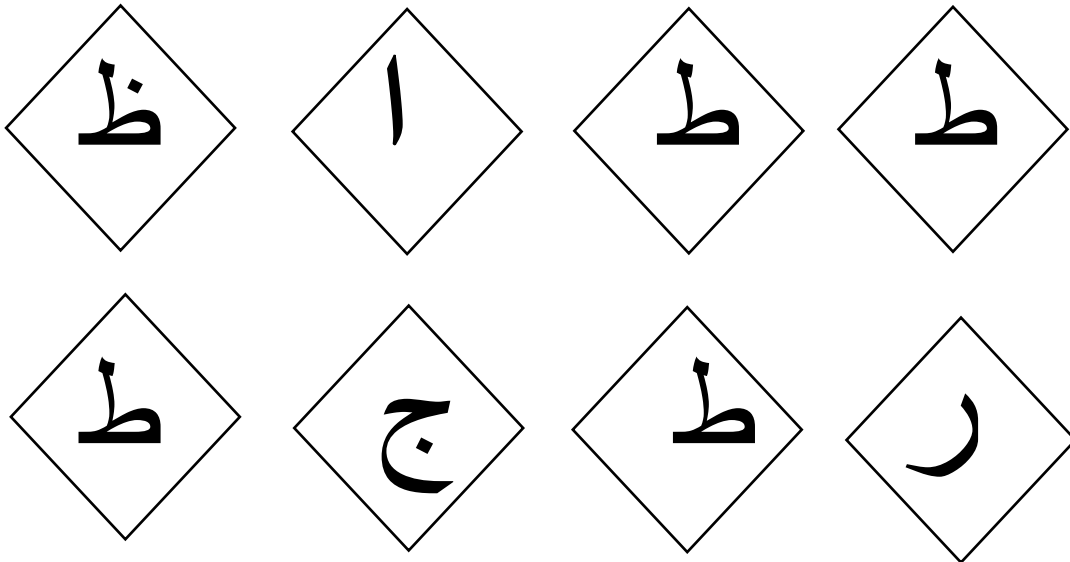
EXERCISE 74: LETTER RECOGNITION

Colour only the shapes which have the letter ظ

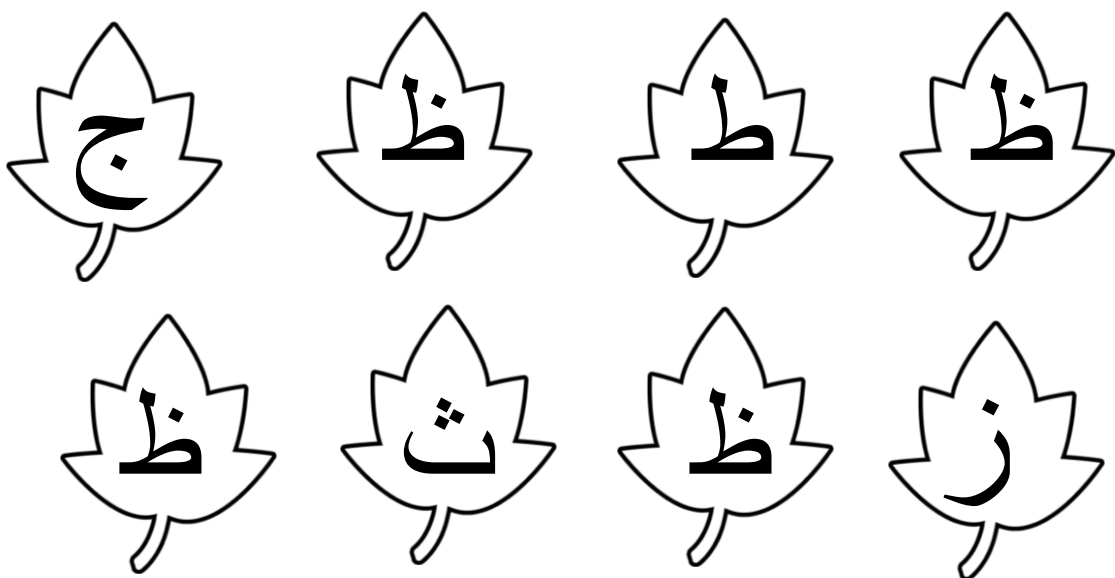

EXERCISE 75: COLOURING EXERCISERECOGNISING LETTERS ظ ص TO ظ

Colour the picture below according to the letters.

ظ	ط	ض	ص
Grey	Yellow	Black	Brown

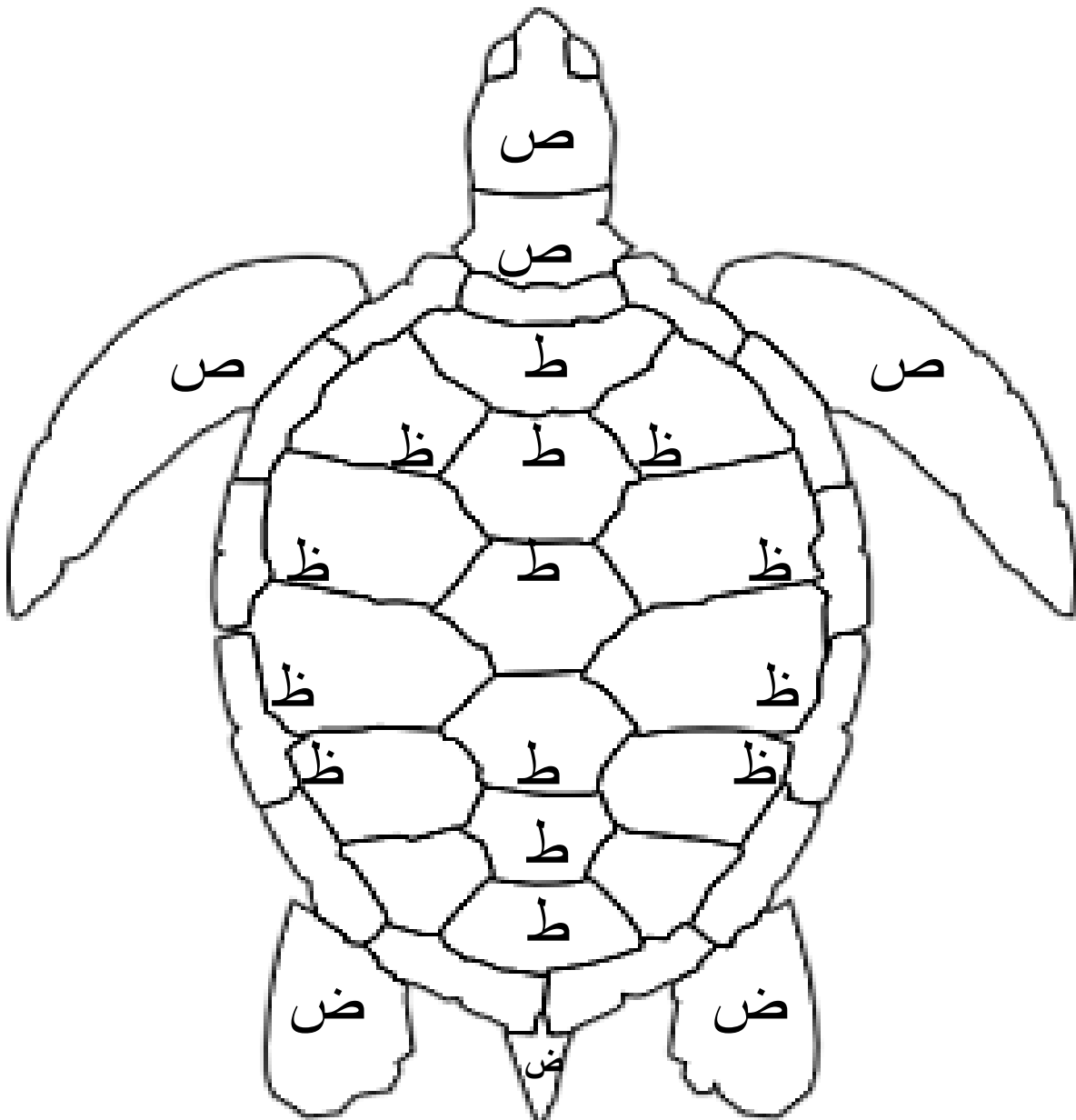

EXERCISE 76: READING EXERCISERECOGNISING LETTERS ظ ص TO ص

Read and identify the alphabets			
ظ	ط	ض	ص
Zhe	Tta	Dhaad	Ssad
ط ظ ص س ض			
ض ث ر ص ظ ط			
ار اض اص اش ط د			
ب ظ ض اش اط اس ص			
ظ ص اذ ض ز ط			

ظ	ط	ض	ص
ظ	ط	ض	ص

EXERCISE 77: COLOURING EXERCISERECOGNISING LETTERS ظ TO ص

Colour the Tortoise below according to the letter.

ظ	ط	ض	ص
Orange	Yellow	Brown	Black

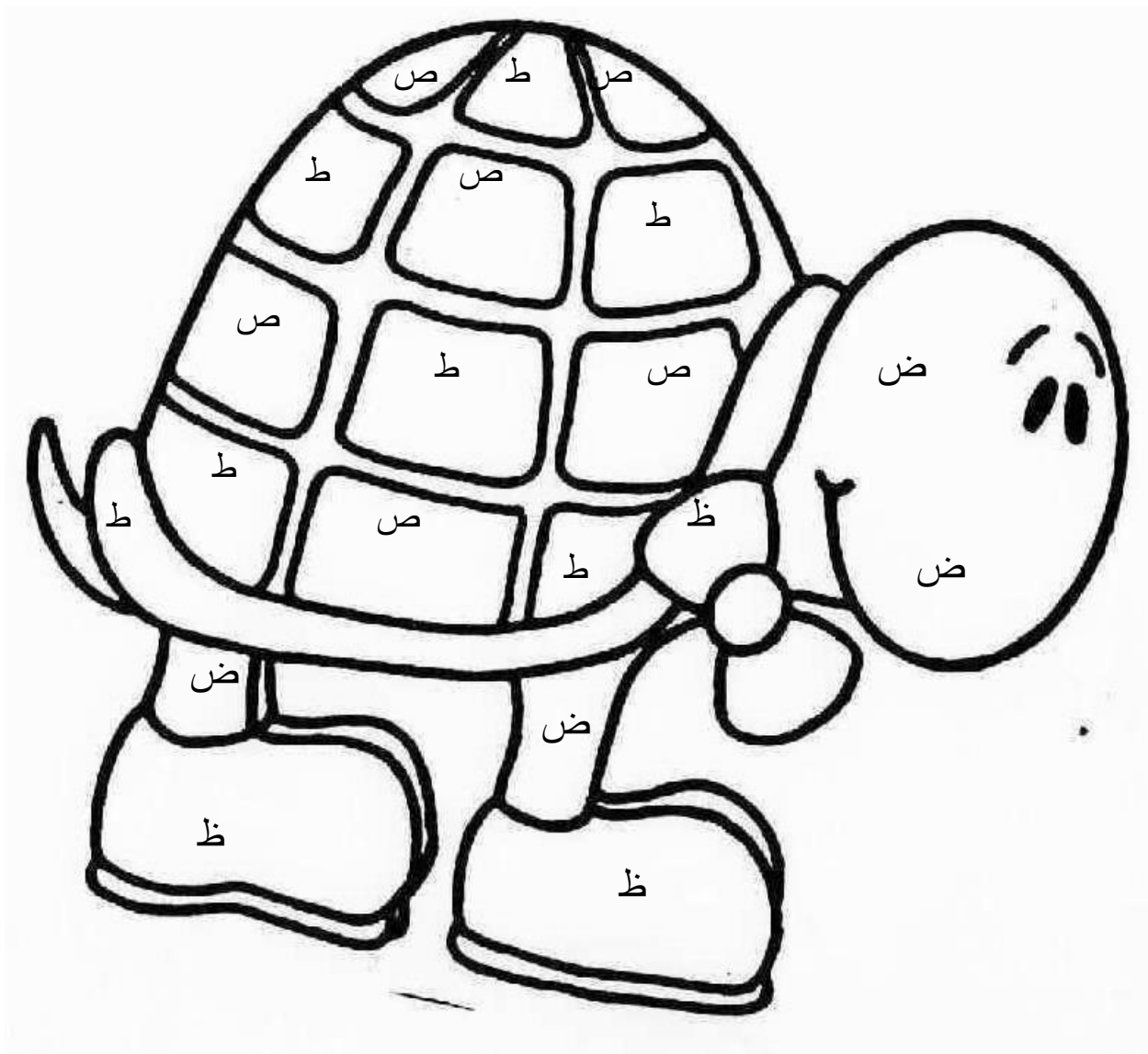

EXERCISE 78: LETTER RECOGNITION

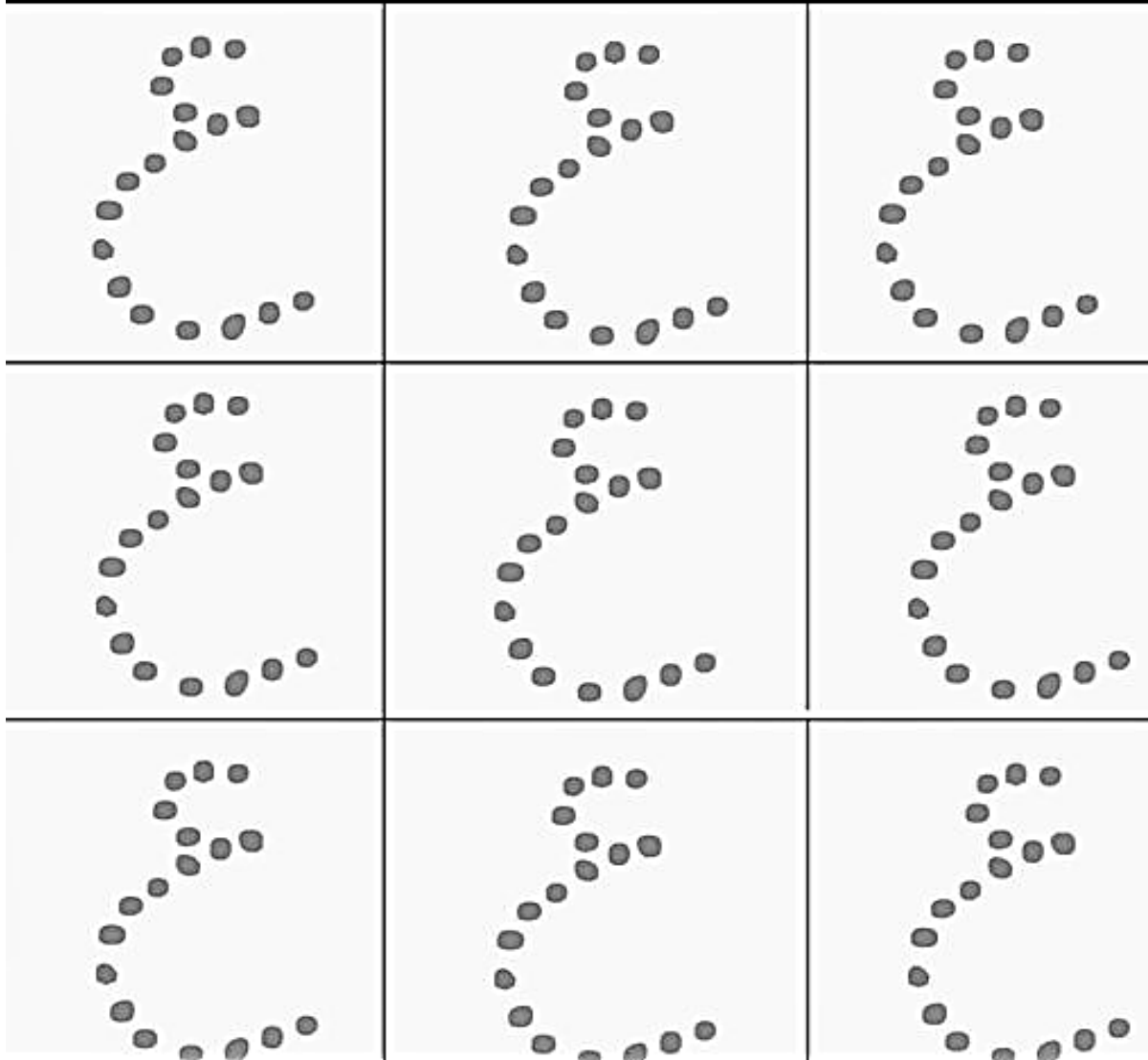
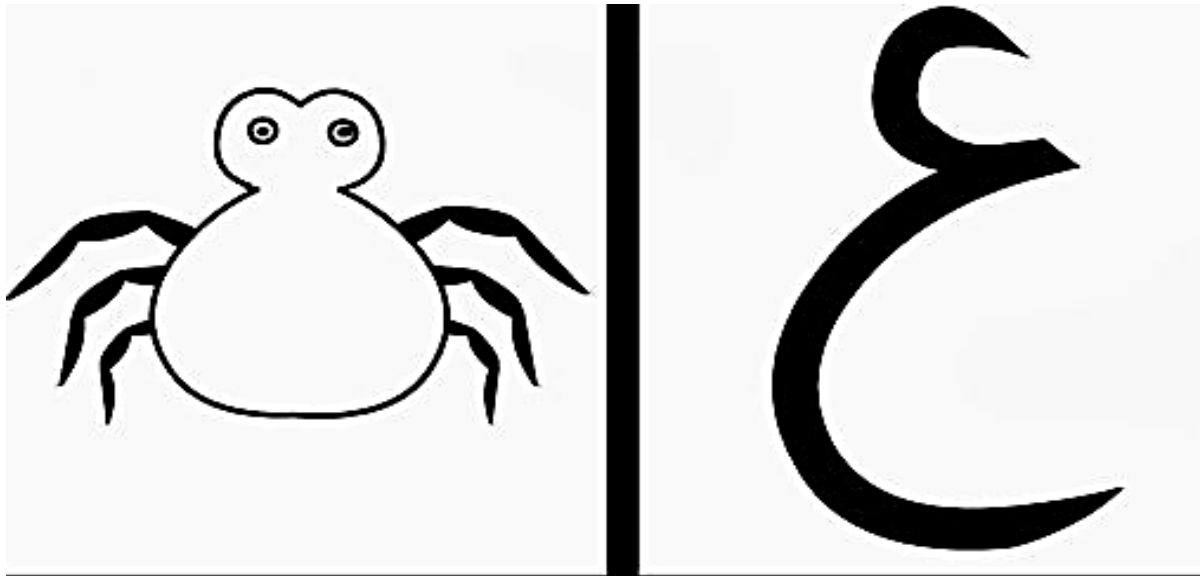

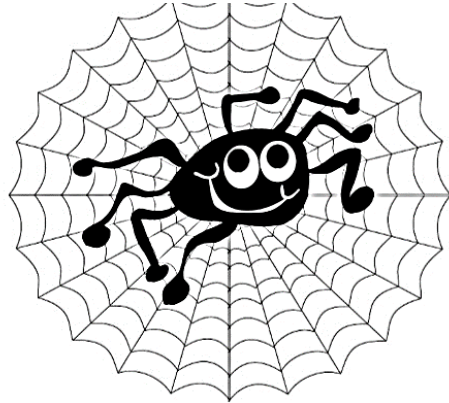
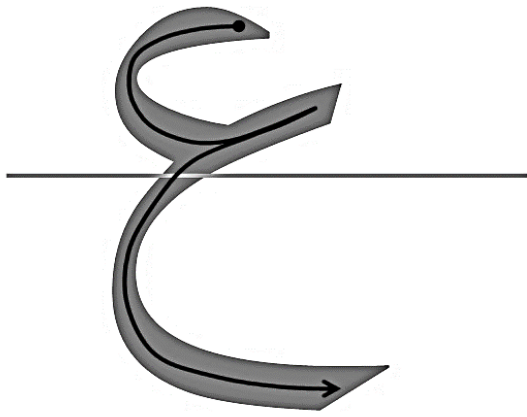
EXERCISE 79: LETTER RECOGNITIONJoin the dots and write the letter.

عنكبوت A'nkaboot

Ain makes the sound "a" as in Abdullah

Read



Write

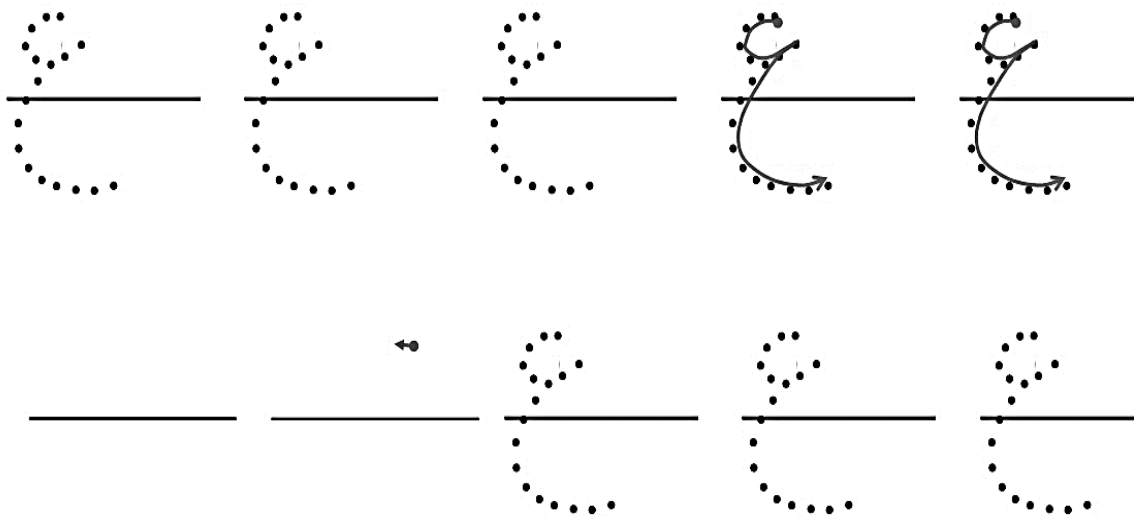

EXERCISE 80: LETTER RECOGNITION

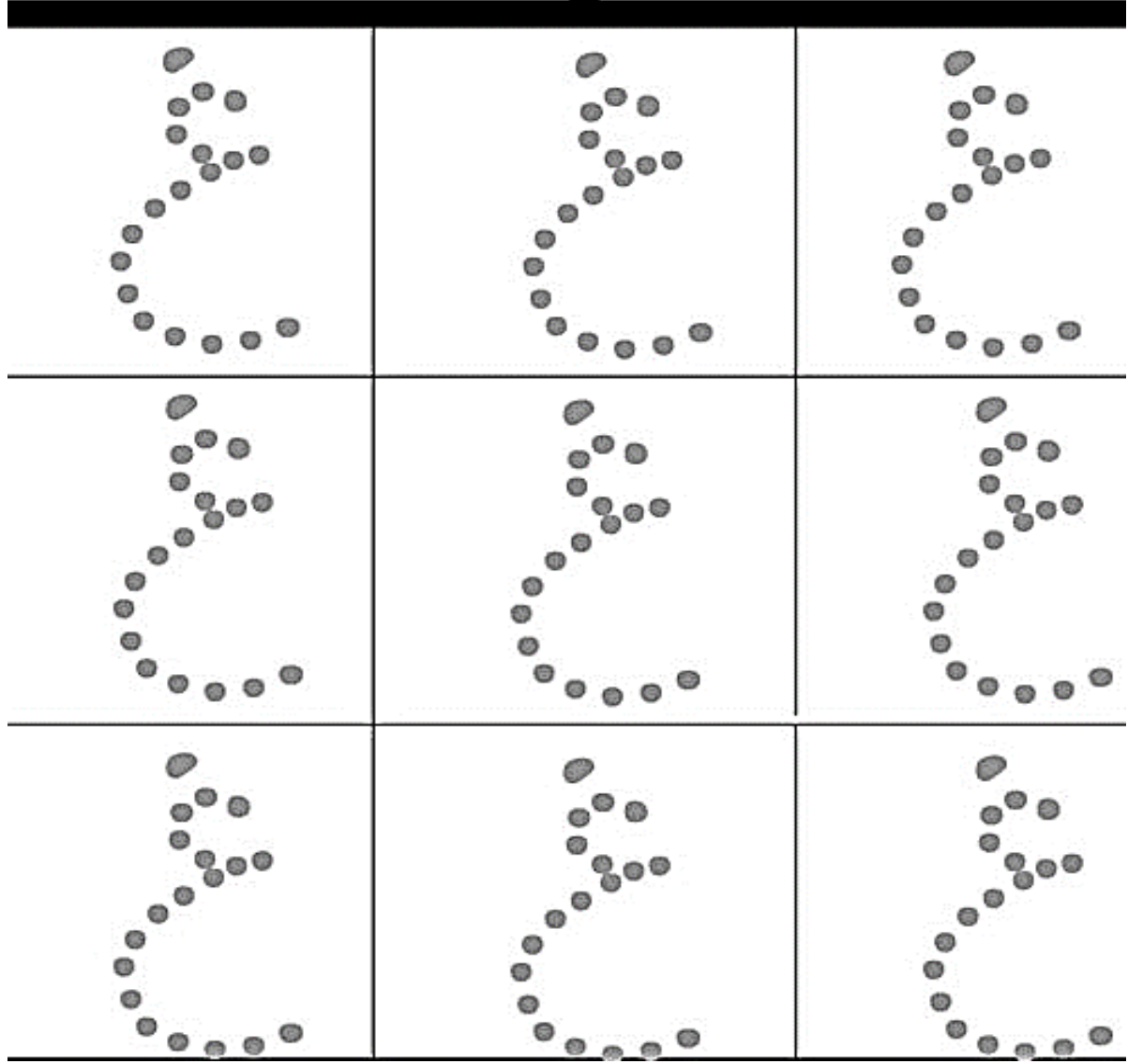
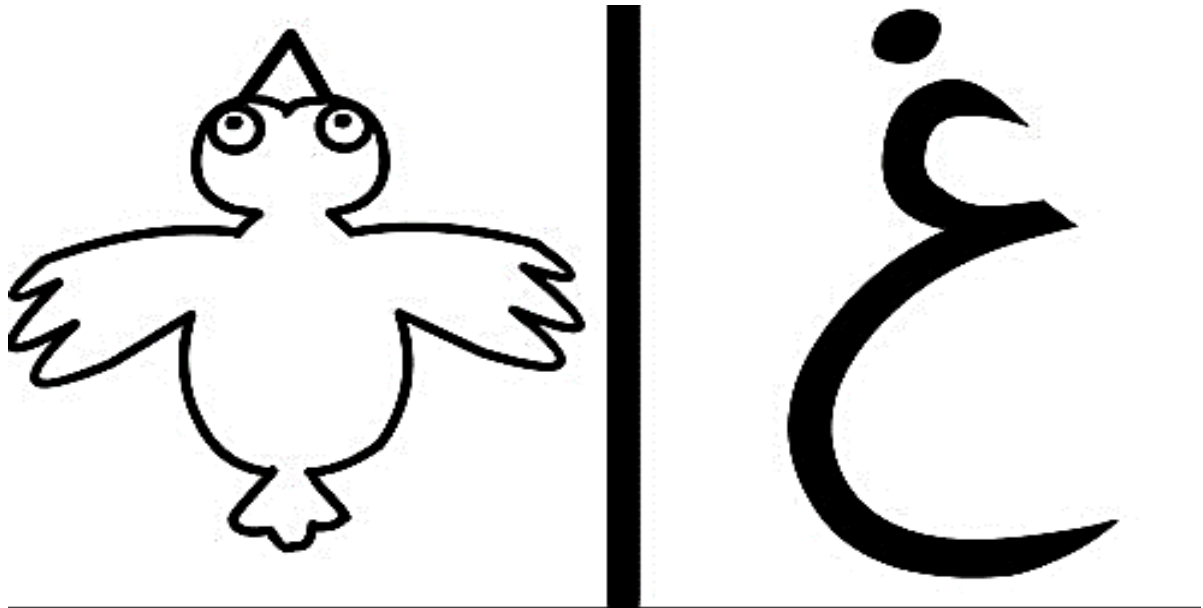

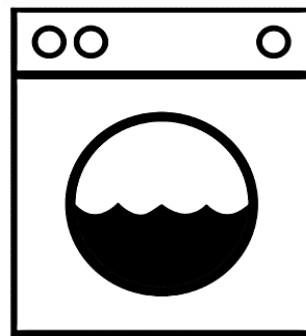
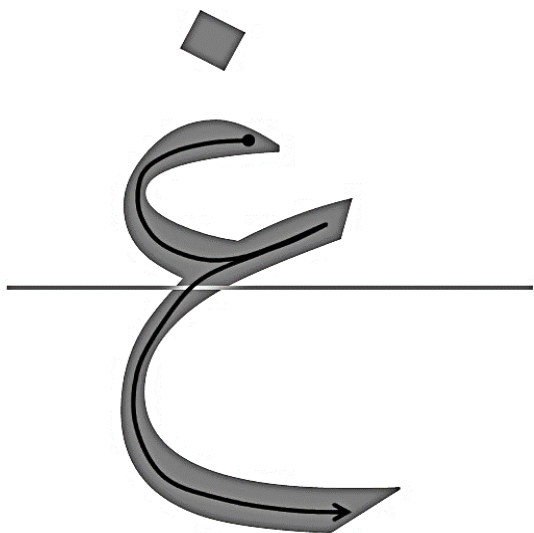
EXERCISE 81: LETTER RECOGNITIONJoin the dots and write the letter.

غسالة Gassaalah

Gain makes the sound 'gha' as in Maghrib

Read



Write

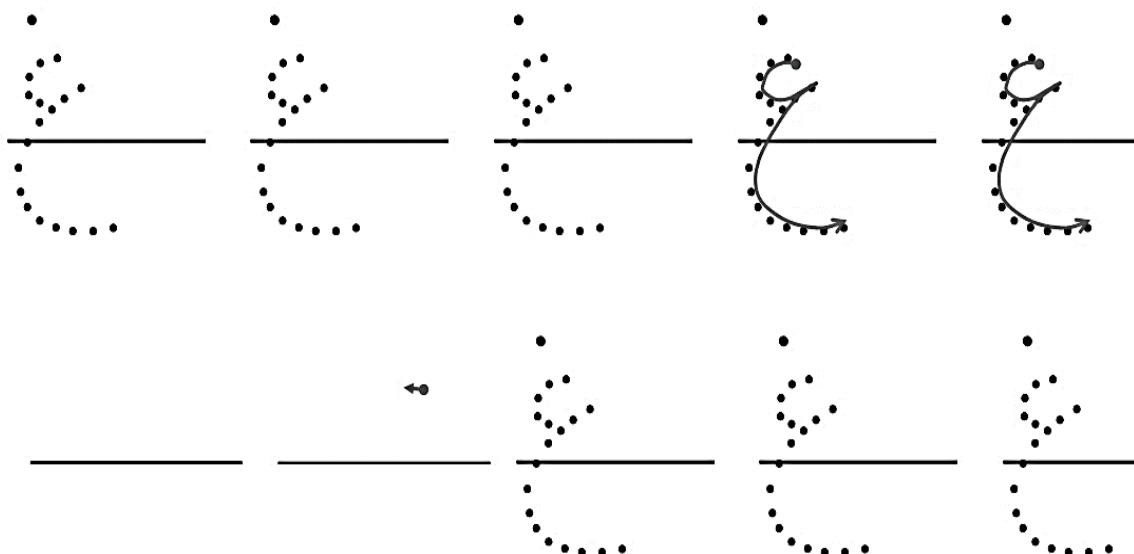

EXERCISE 82: LETTER RECOGNITION

Colour only the Shapes which have the letter ع ع

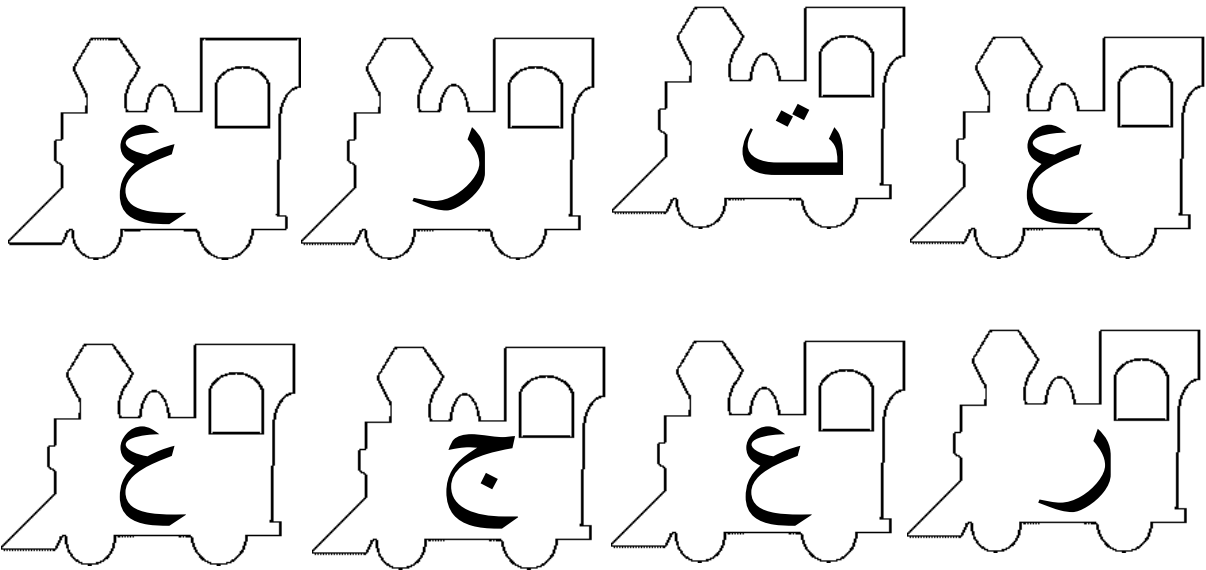
EXERCISE 83: LETTER RECOGNITION

Colour only the shapes which have the letter غ غ

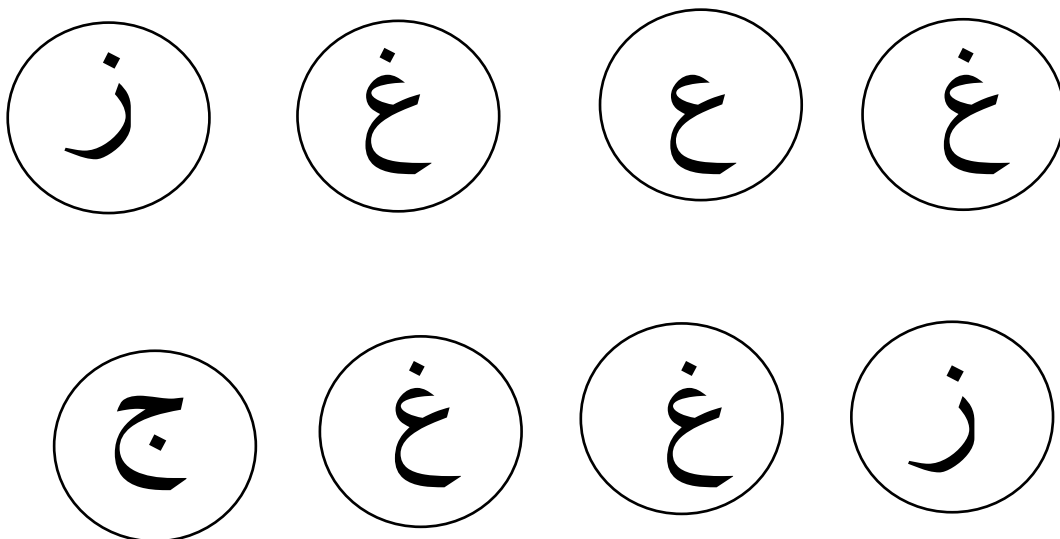

EXERCISE 84: LETTER RECOGNITION

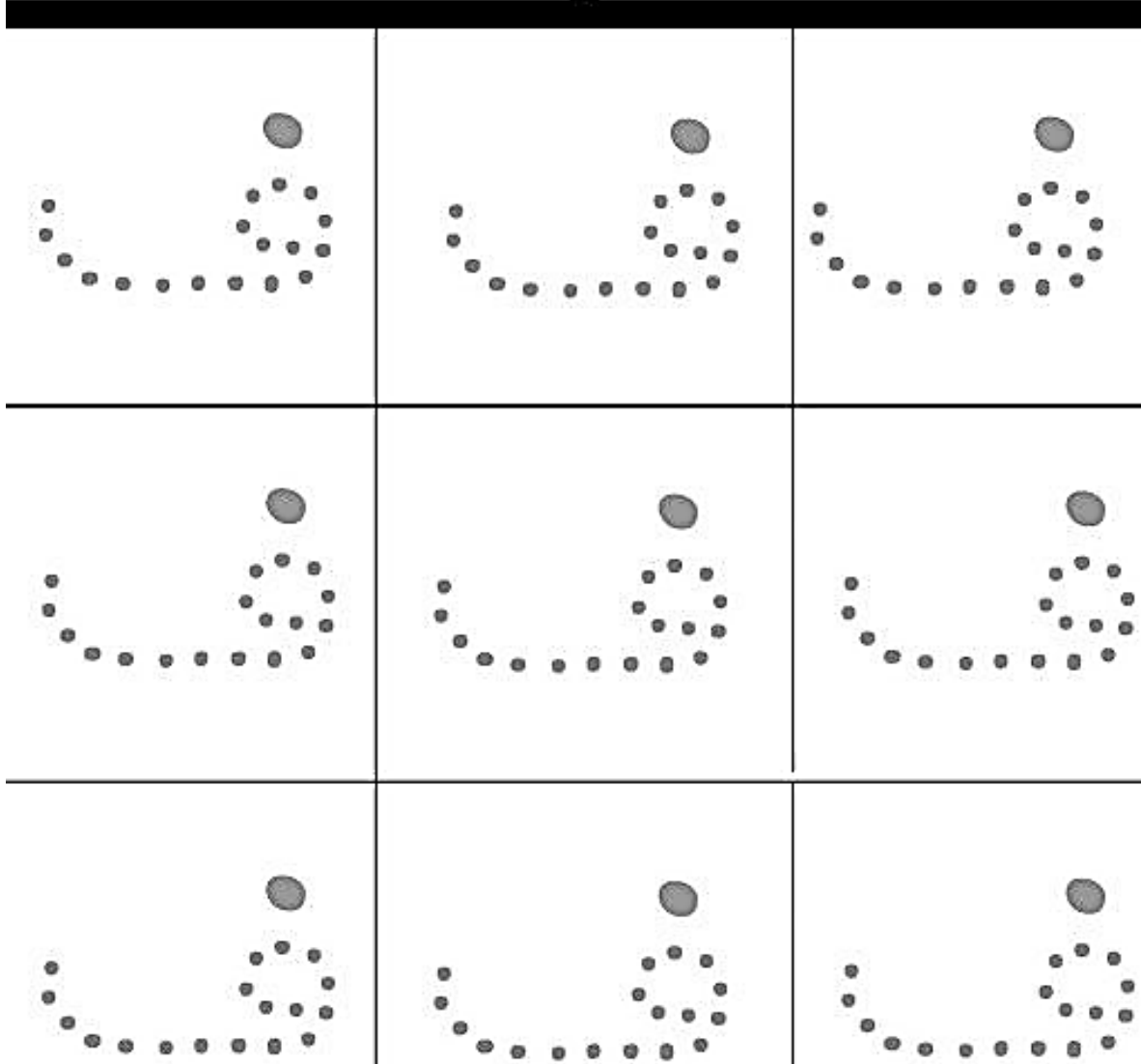
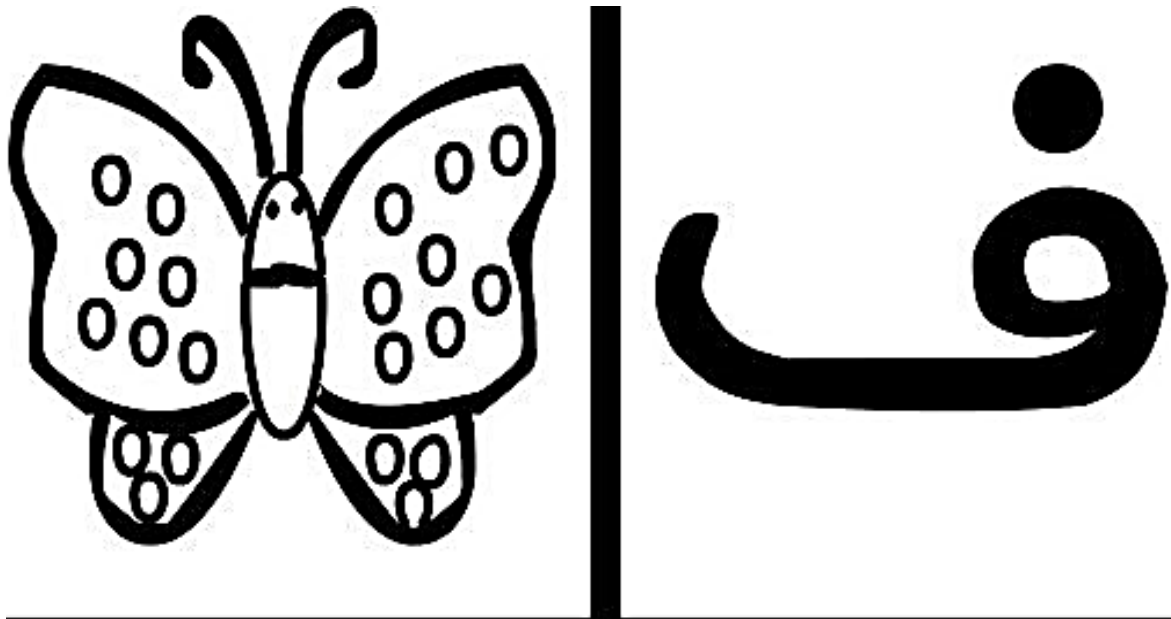

EXERCISE 85: LETTER RECOGNITION

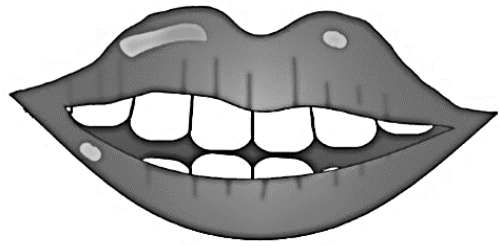
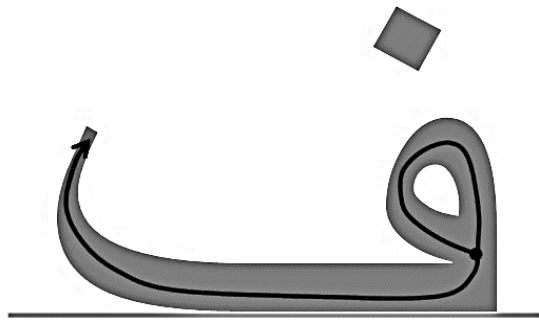

Fa makes the sound 'fa' as in fat

فم

Fam

Read

ف ف ف ف ف

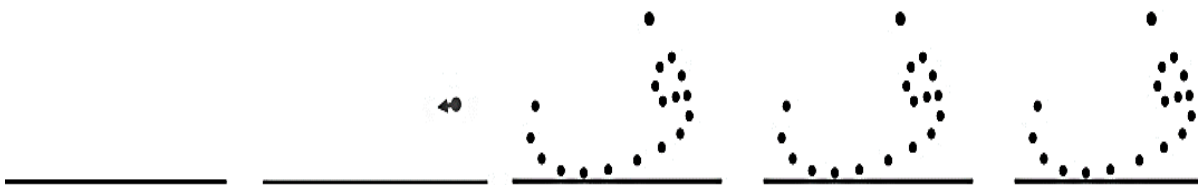

EXERCISE 86: LETTER RECOGNITION

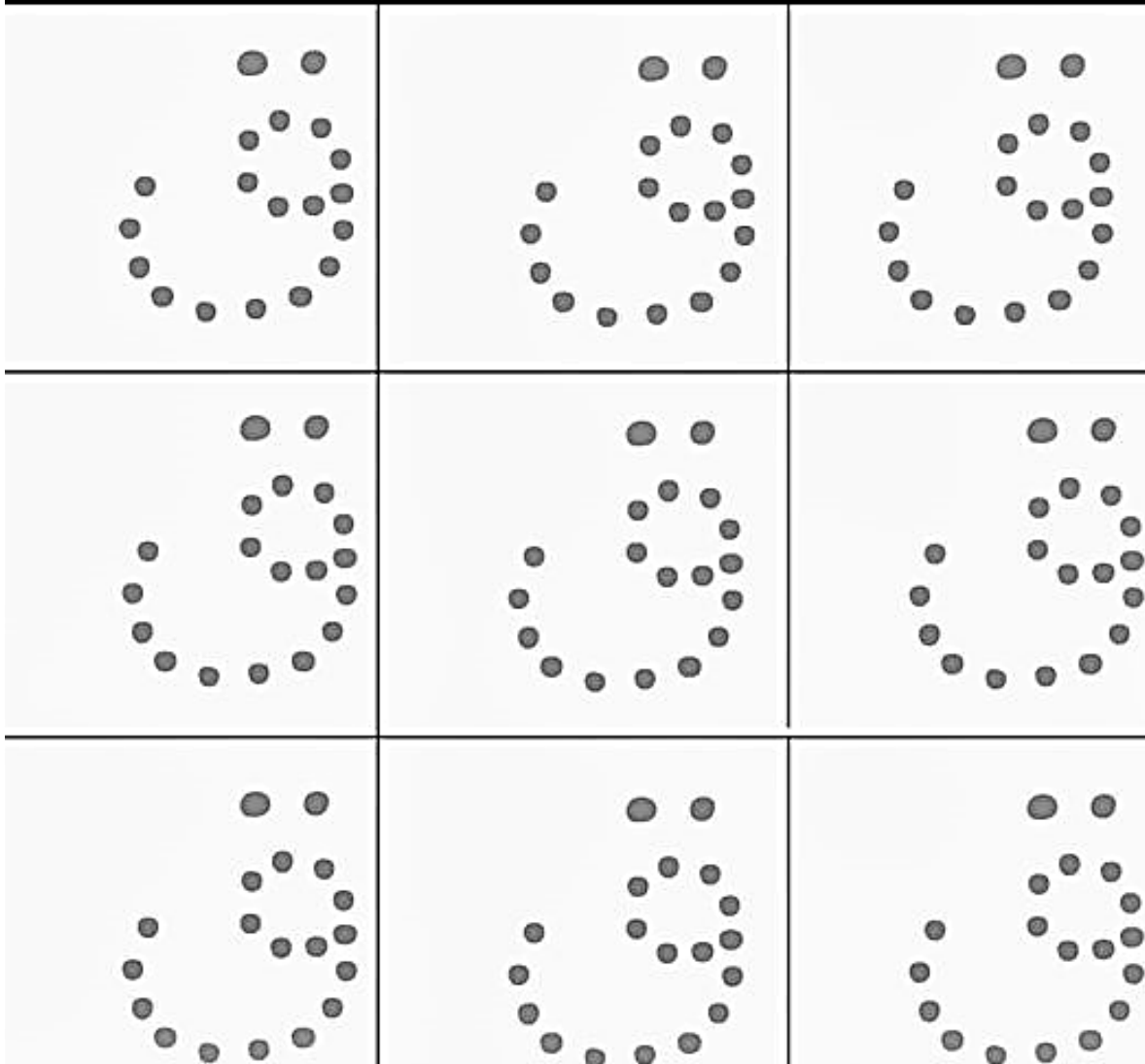
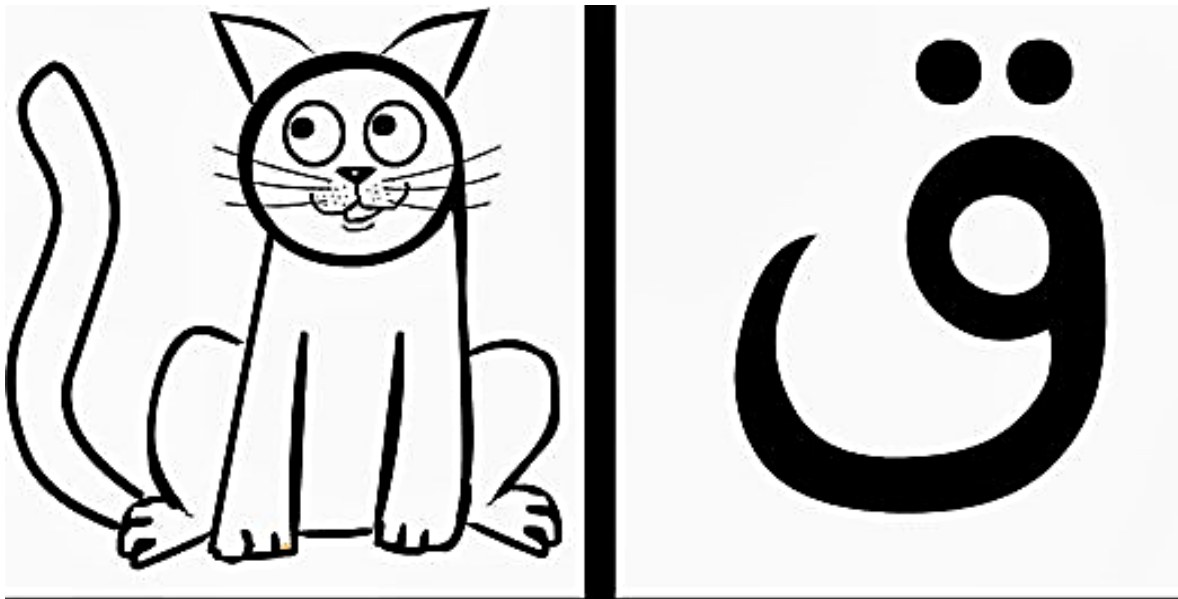

EXERCISE 87: LETTER RECOGNITION

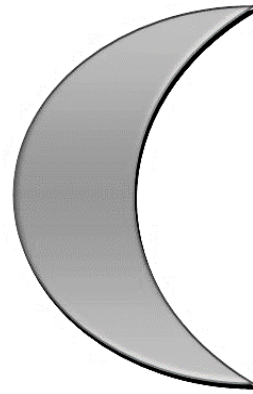
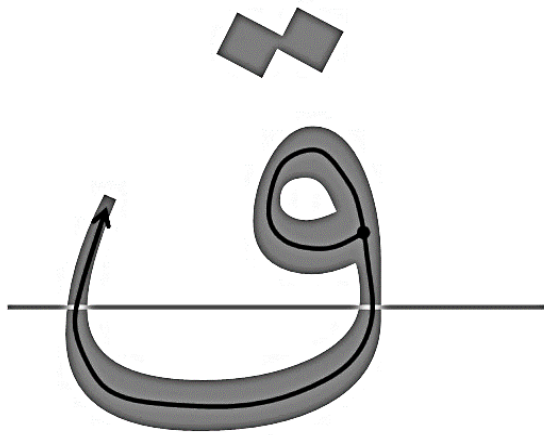

Qaf makes the sound 'qa'

قمر Qamar

Read

ق ق ق ق ق ق

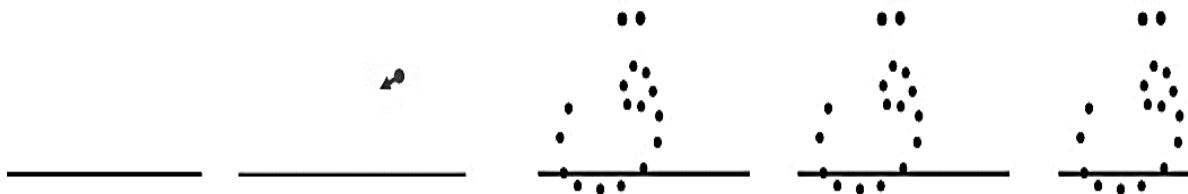
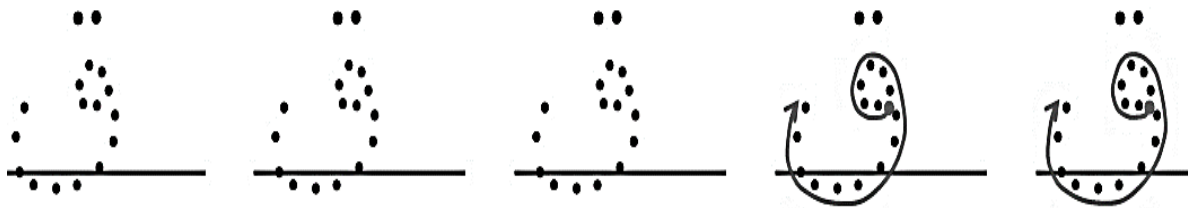

EXERCISE 88: LETTER RECOGNITION

Colour only the Shapes which have the letter ف ف

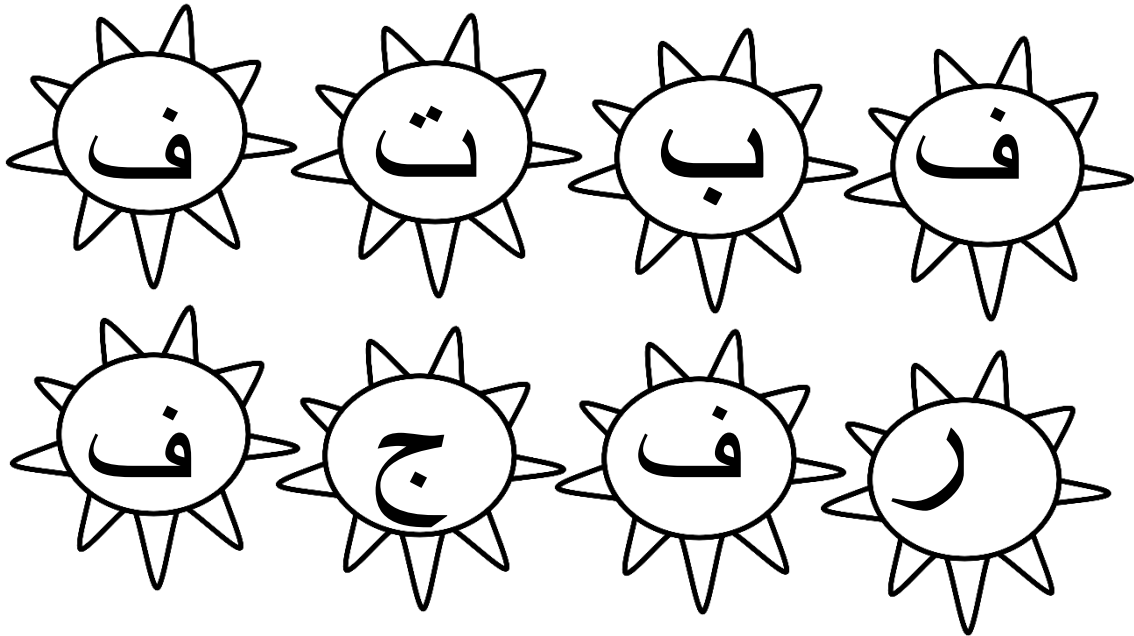
EXERCISE 89: LETTER RECOGNITION

Colour only the shapes which have the letter ق ق

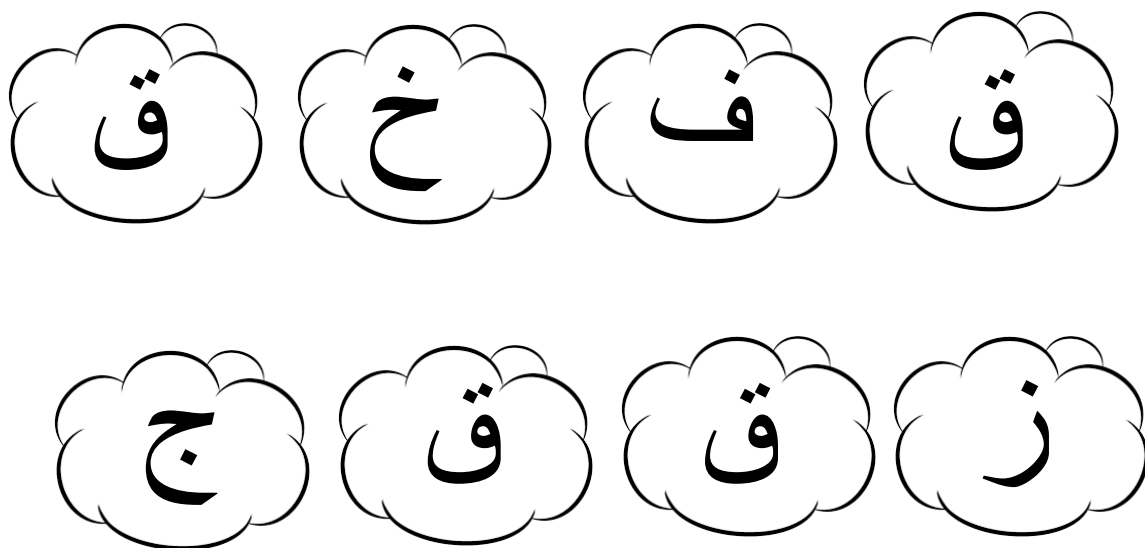

EXERCISE 90: COLOURING EXERCISERECOGNISING LETTERS ق TO ع

Colour the picture below according to the letters.

ق	ف	غ	ع
Red	Yellow	Black	Green

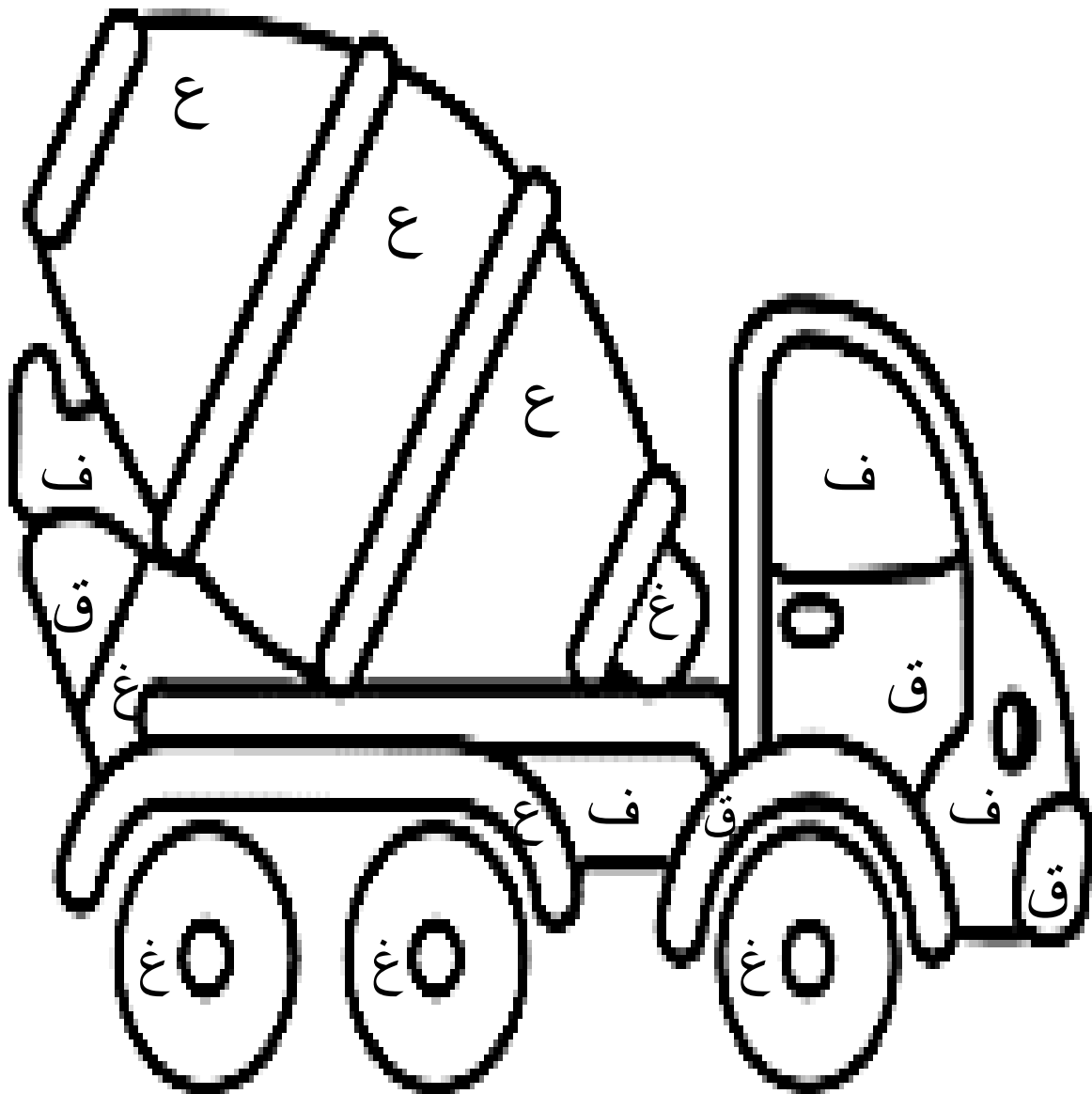

EXERCISE 91: READING EXERCISERECOGNISING LETTERS ق TO ع

Read and identify the alphabets			
ق	ف	غ	ع
Qaf	Fe	Ghayn	Ayn
ظ	ق	ف	ض
ث	ع	ف	ص
ق	ظ	ع	ط
اق	اض	اف	غ
ق	ظ	ع	اط
ق	ظ	ع	اس
ظ	ف	اذ	ق
غ	ز	ق	غ

ق	ف	غ	ع
ق	ف	غ	ع
ق	ف	غ	ع
ق	ف	غ	ع

EXERCISE 92: COLOURING EXERCISERECOGNISING LETTERS ق TO ع

Colour the Lotus flower below according to the letter.

ق	ف	غ	ع
Yellow	Purple	Pink	Green

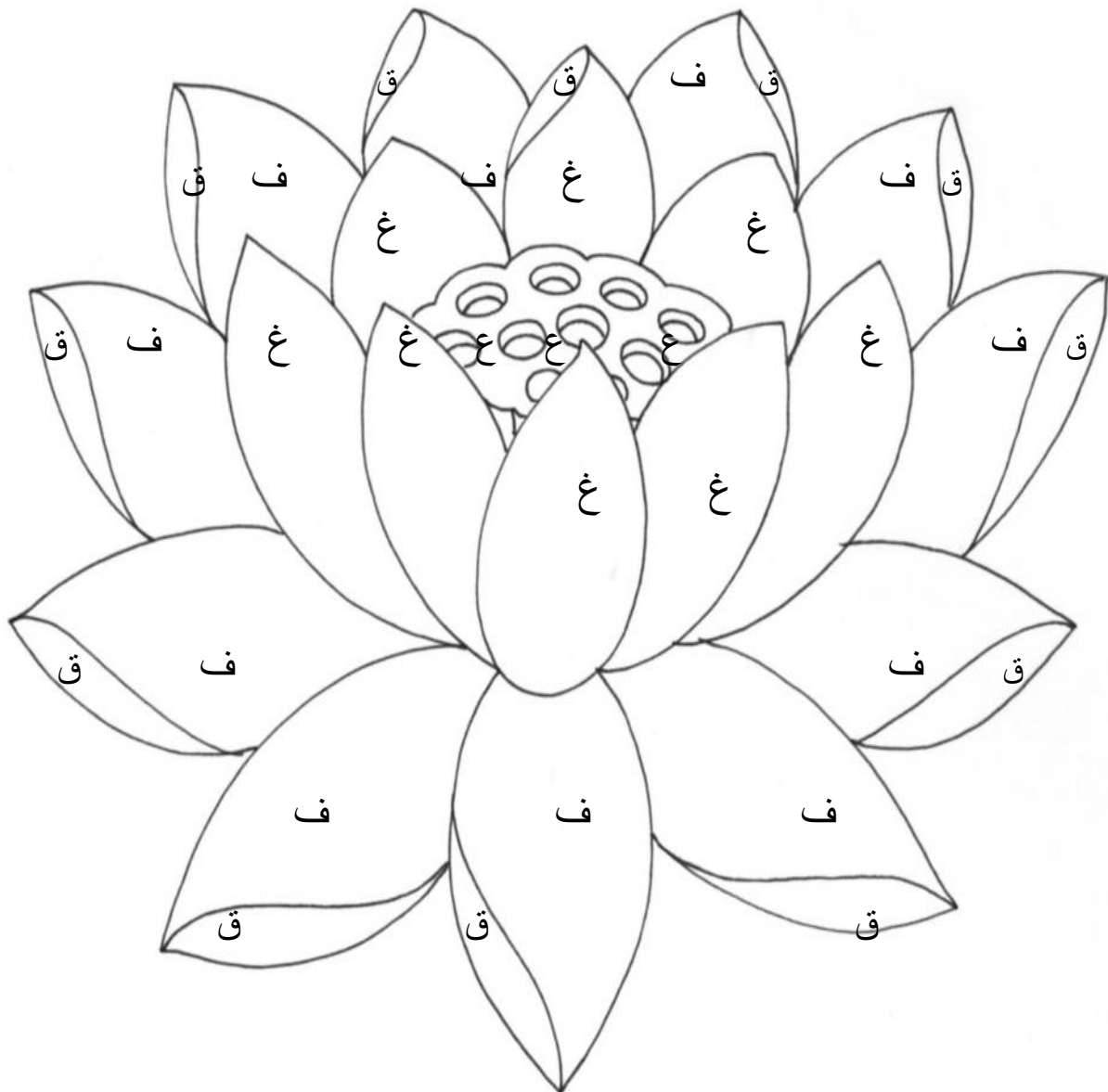

EXERCISE 93: LETTER RECOGNITION

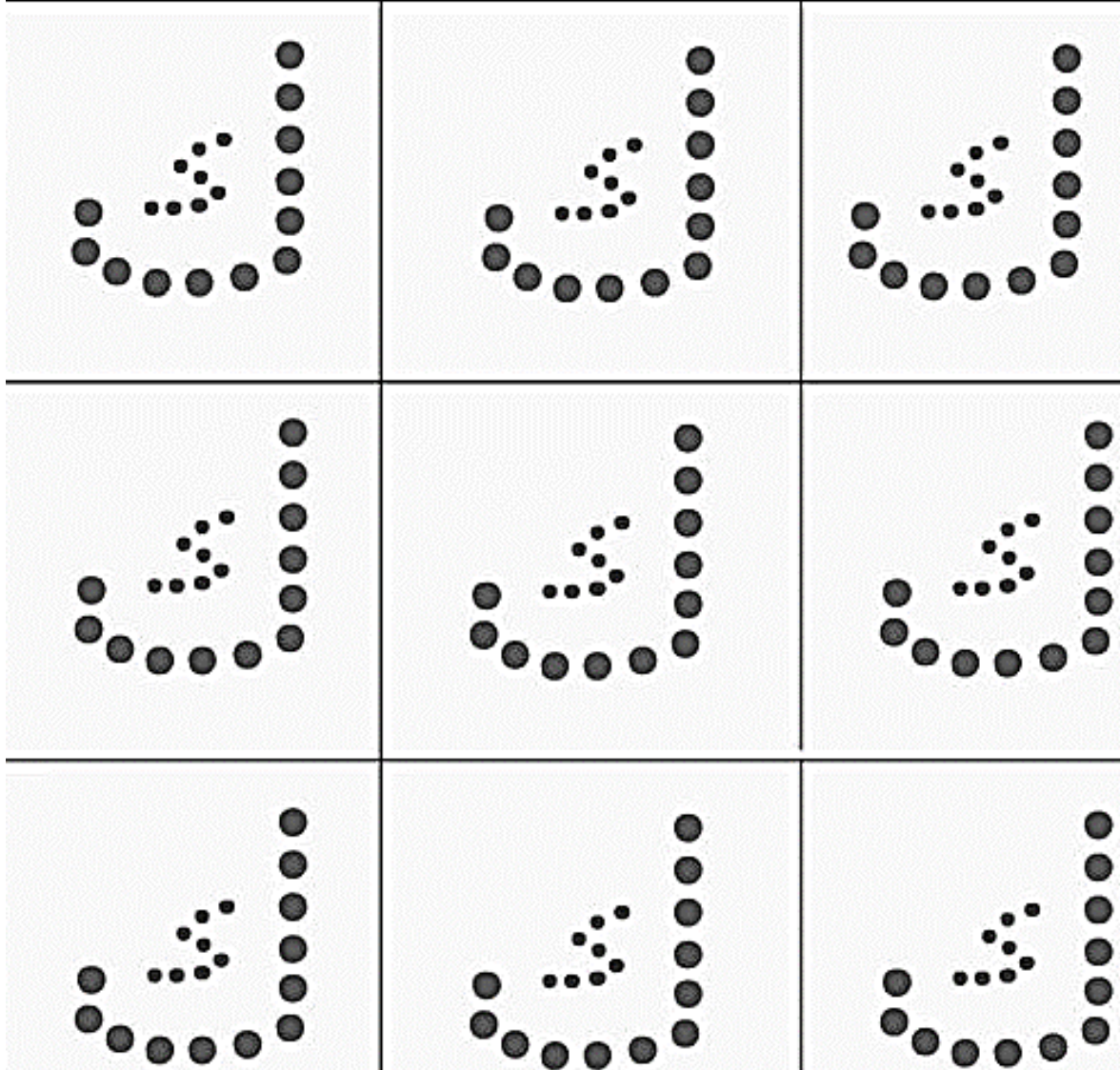
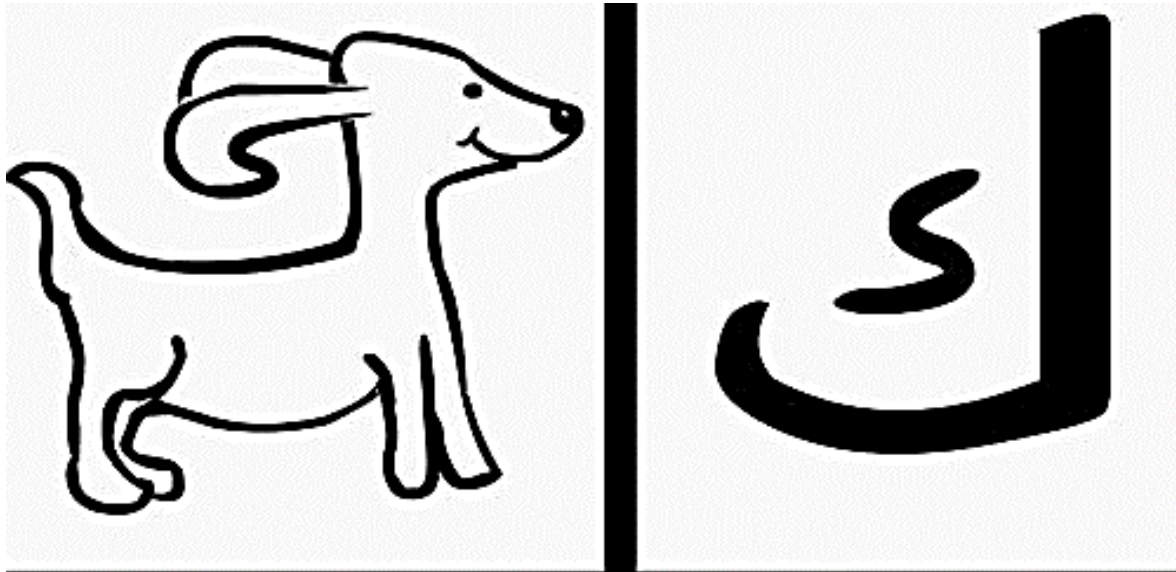

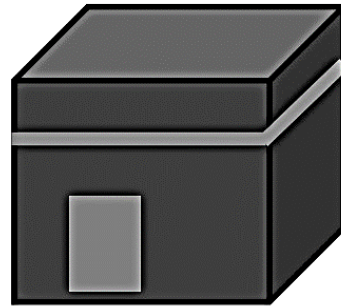
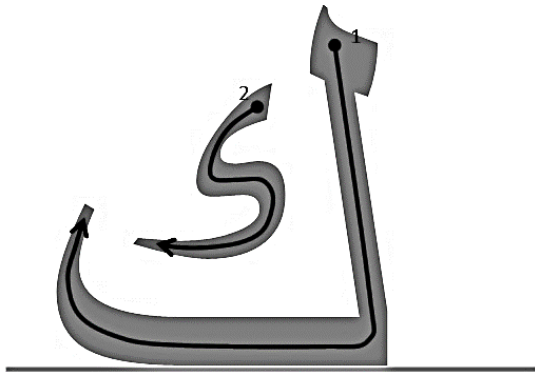
EXERCISE 94: LETTER RECOGNITION

Kaf makes the sound 'ka' as in ka'ba كعبة Ka'ba

Read

ك ك ك ك ك ك

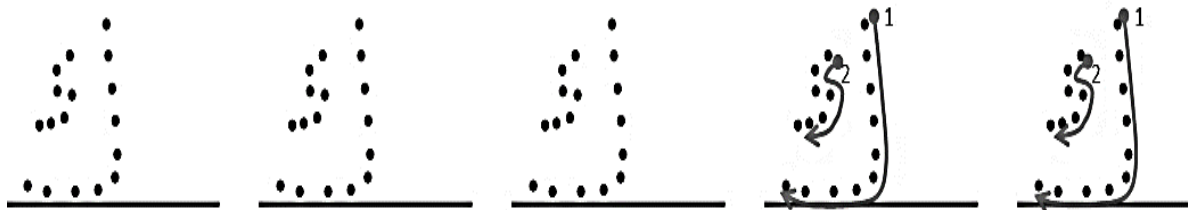

EXERCISE 95: LETTER RECOGNITION

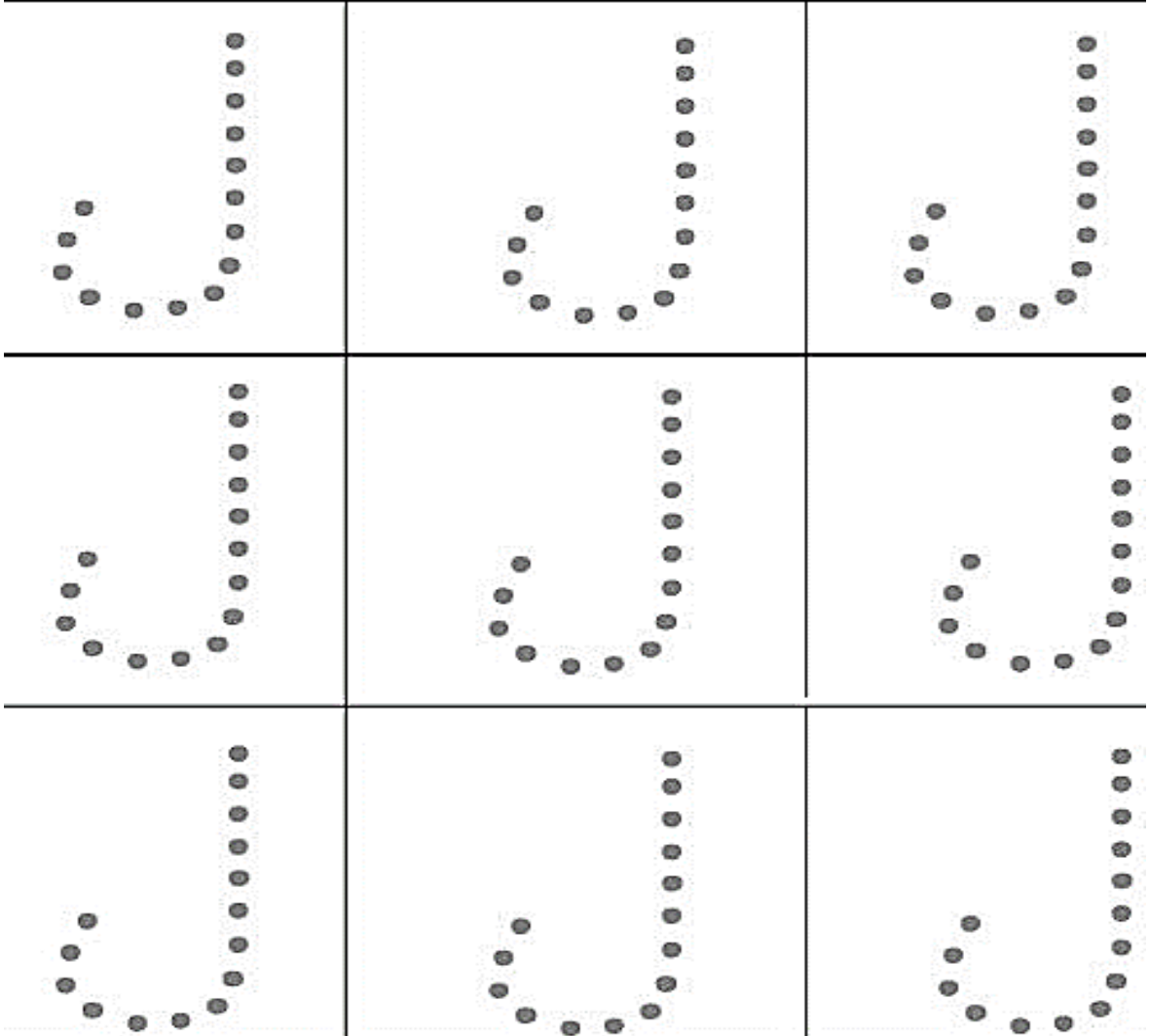
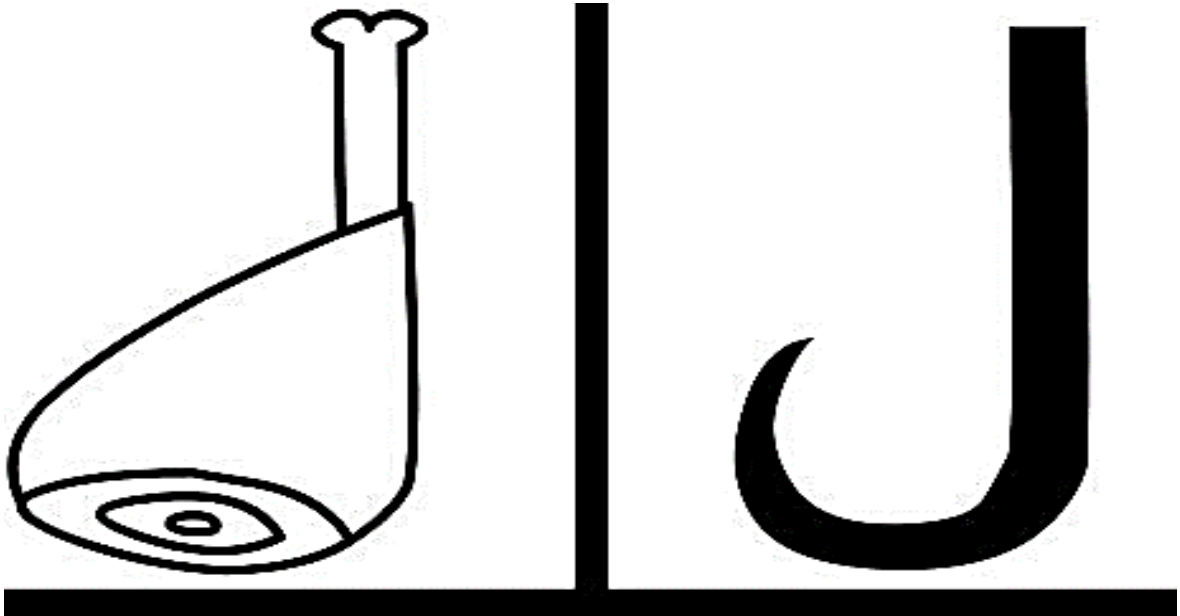

EXERCISE 96: LETTER RECOGNITION

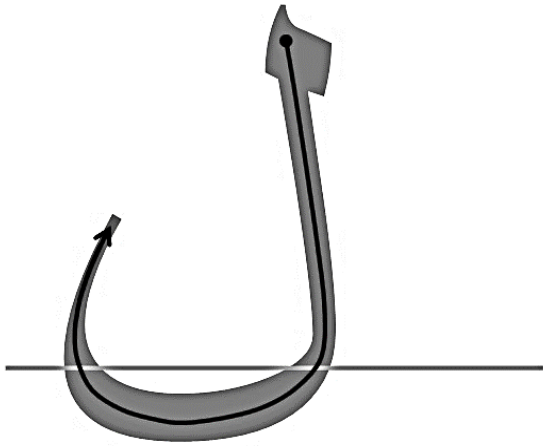

Laam makes the sound 'la' as in laugh **لوز** Lawz

Read

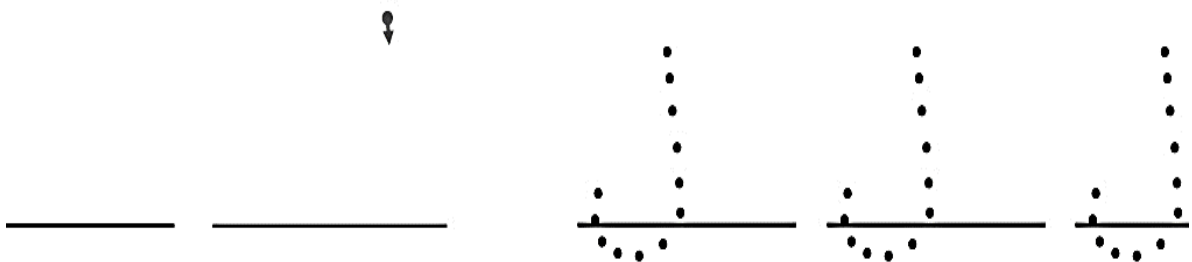

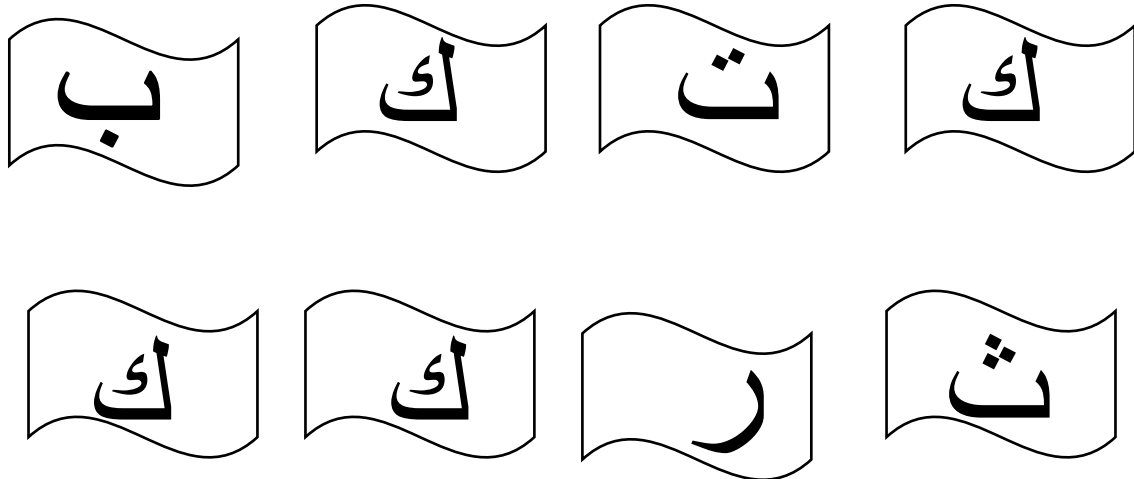
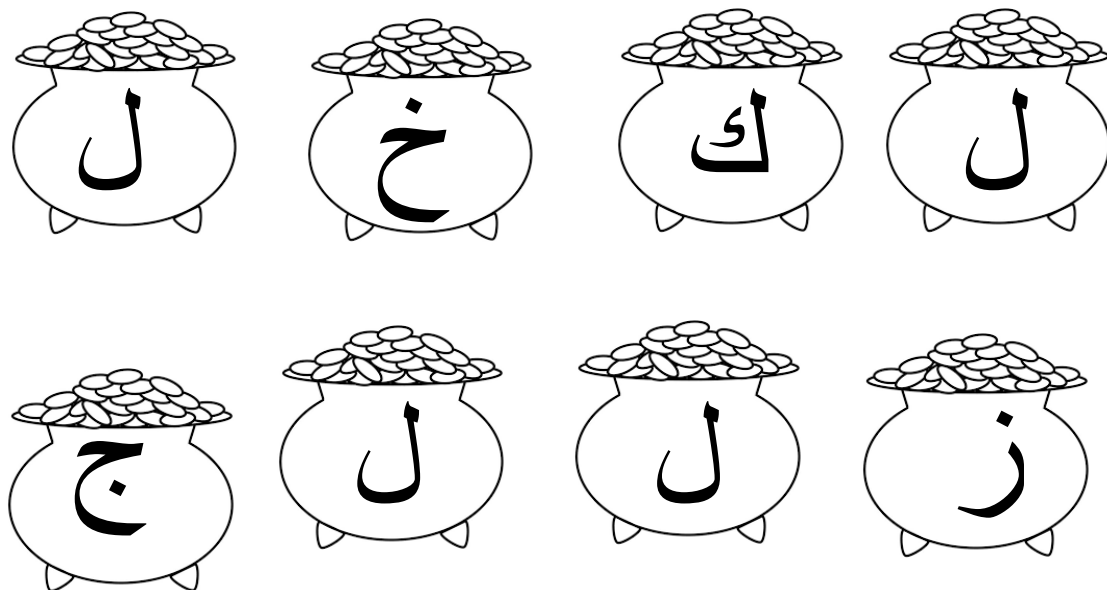
EXERCISE 97: LETTER RECOGNITIONColour only the Shapes which have the letter كEXERCISE 98: LETTER RECOGNITIONColour only the shapes which have the letter ل

EXERCISE 99: LETTER RECOGNITION

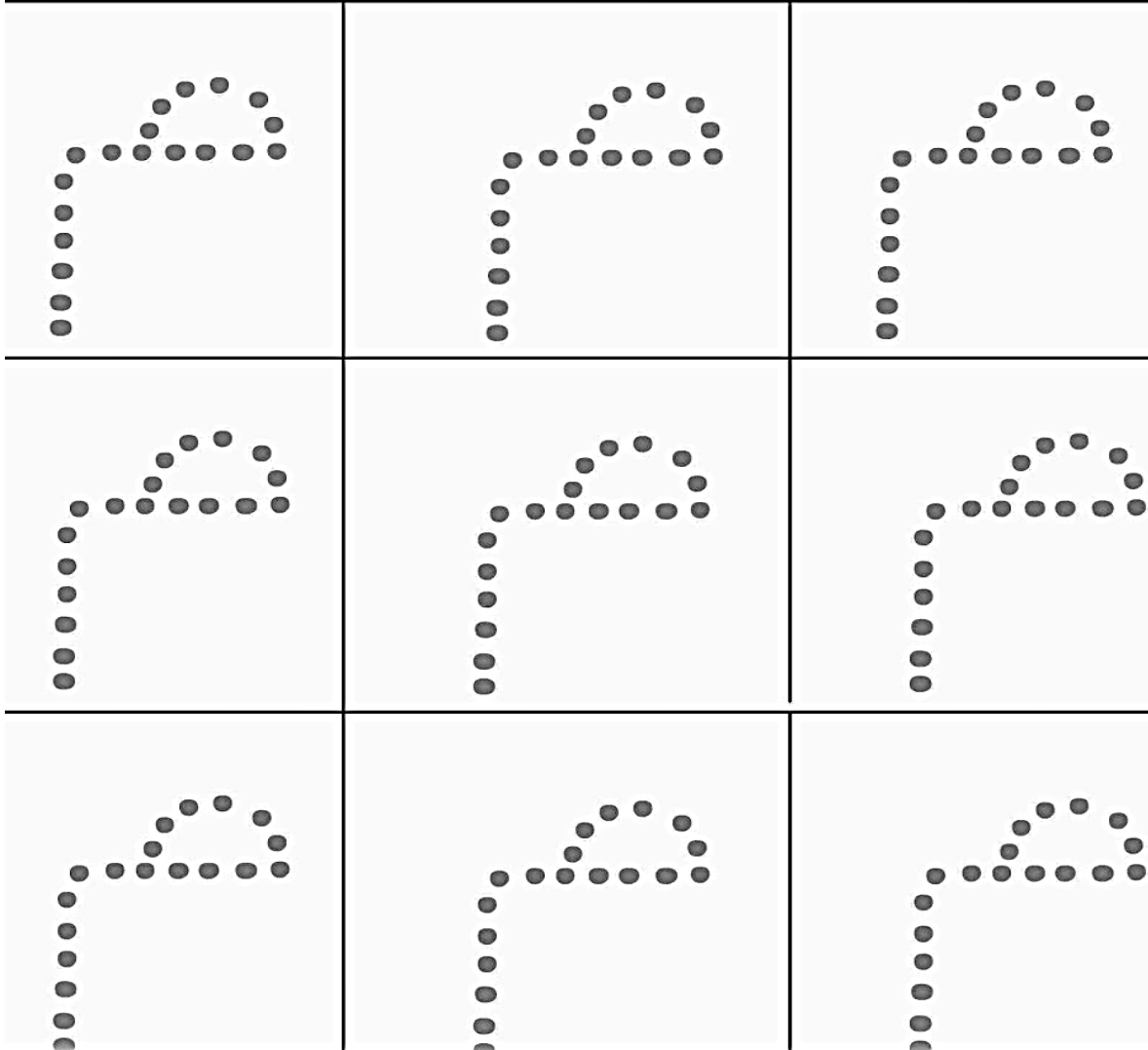
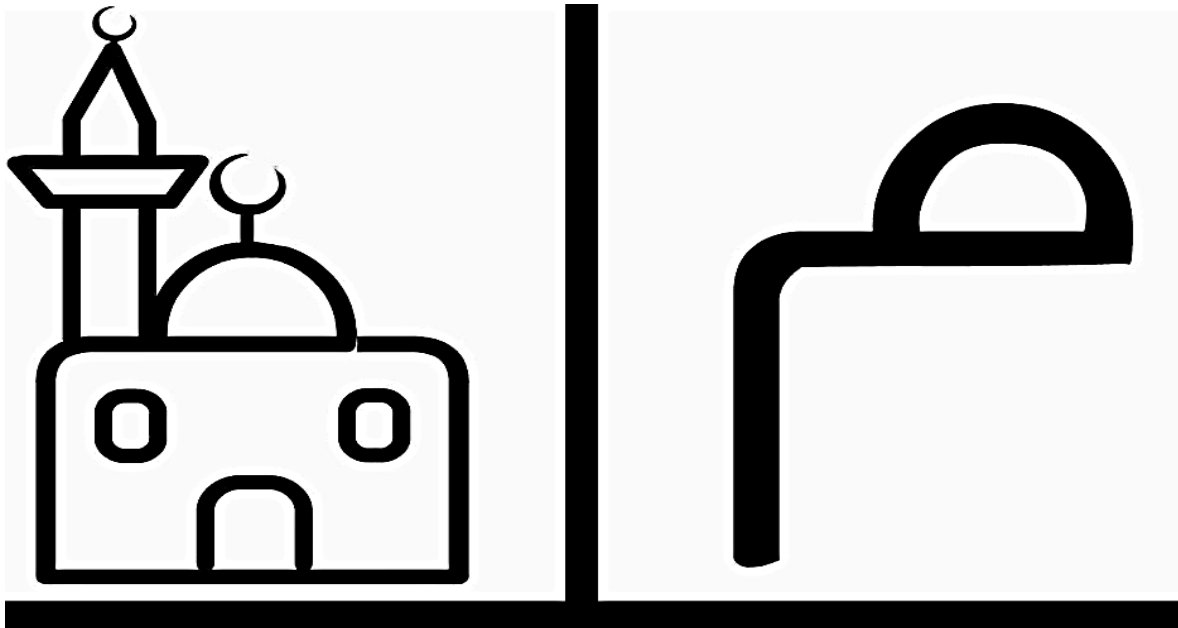

EXERCISE 100: LETTER RECOGNITION

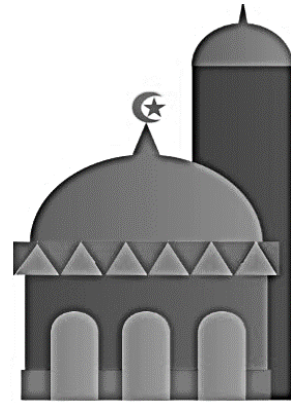
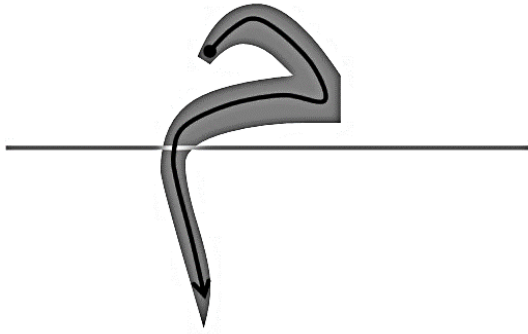

مسجد Masjid

Meem makes the sound 'ma' as in mark

Read

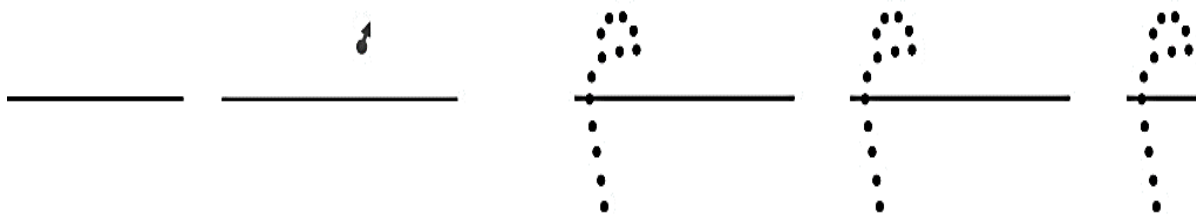
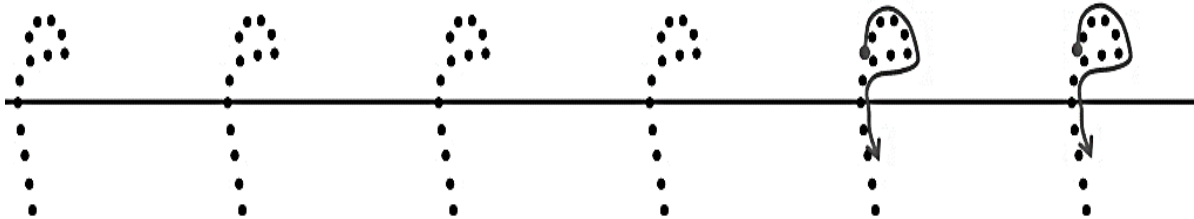

EXERCISE 101: LETTER RECOGNITION

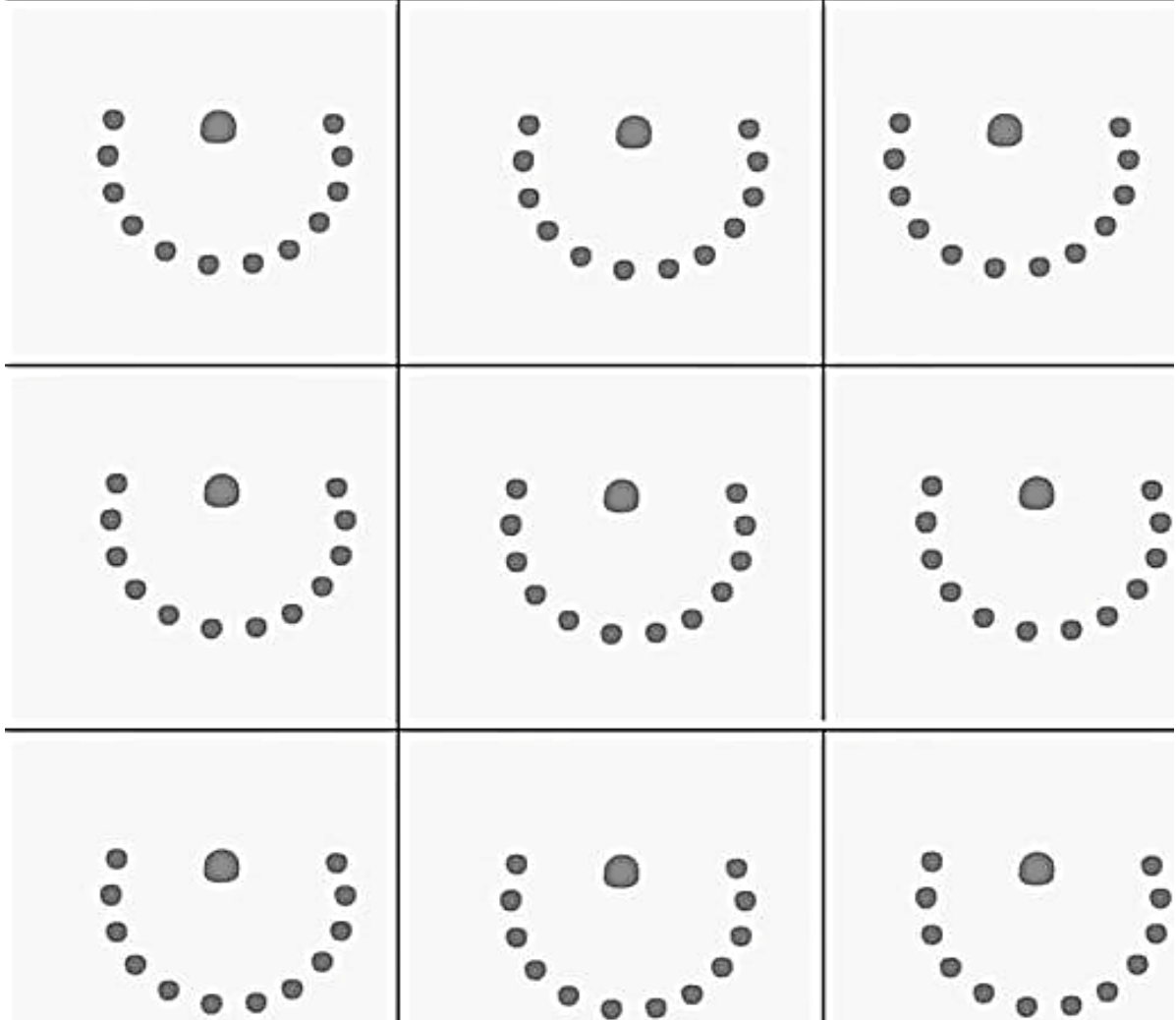
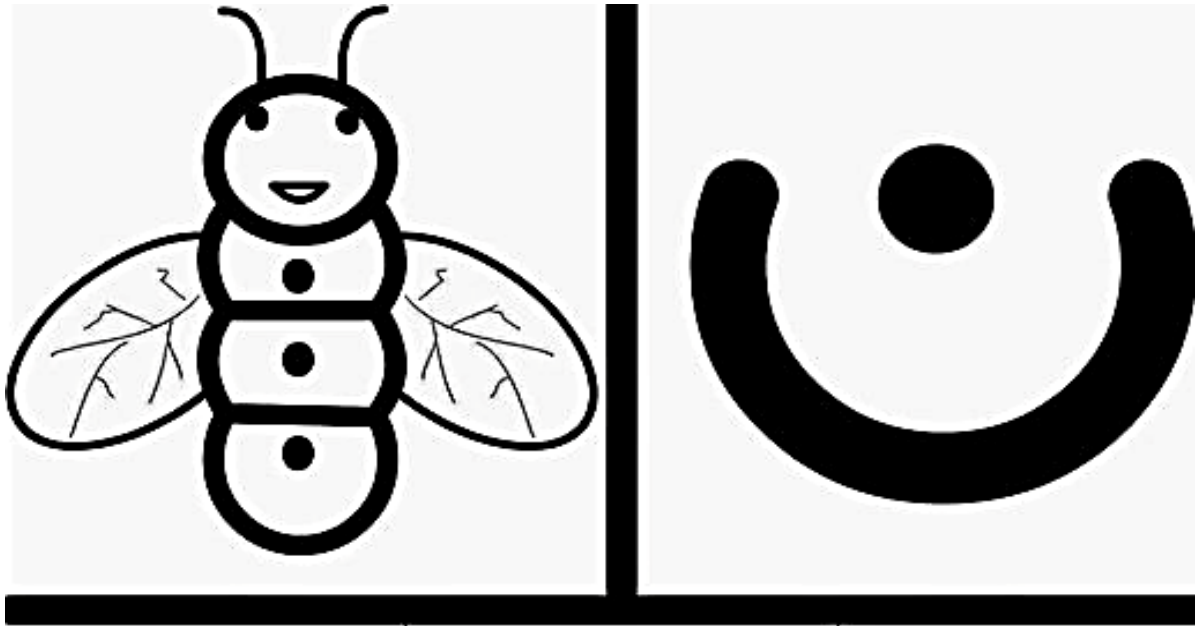

EXERCISE 102: LETTER RECOGNITION

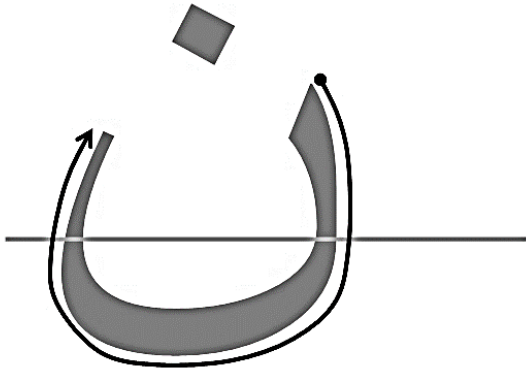

نجم Najm

Noon makes the sound 'na' as in Nanny

Read

ن ن ن ن ن ن



EXERCISE 103: LETTER RECOGNITION

Colour only the Shapes which have the letter م

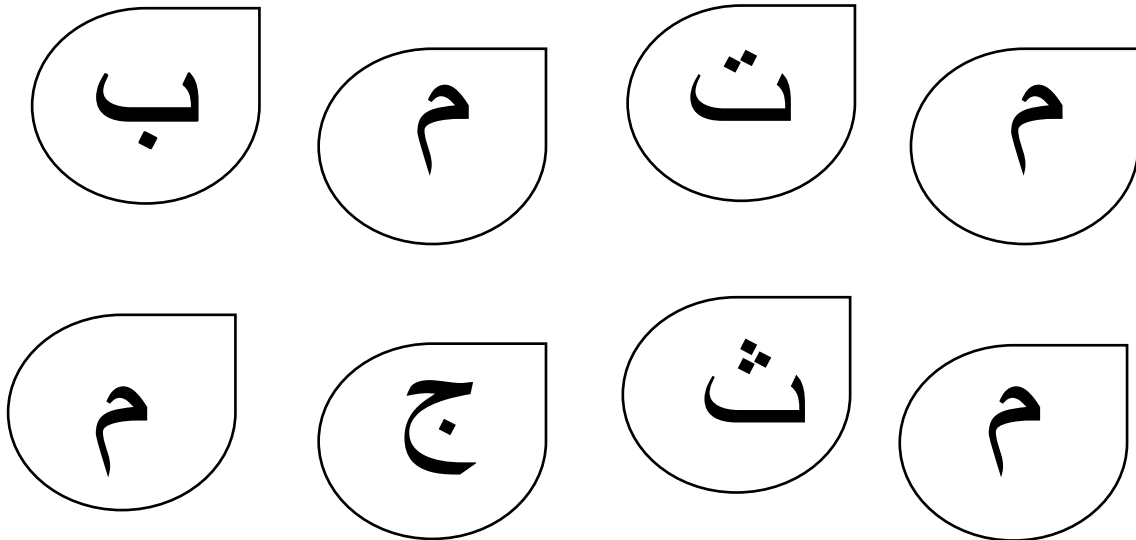
EXERCISE 104: LETTER RECOGNITION

Colour only the shapes which have the letter ن

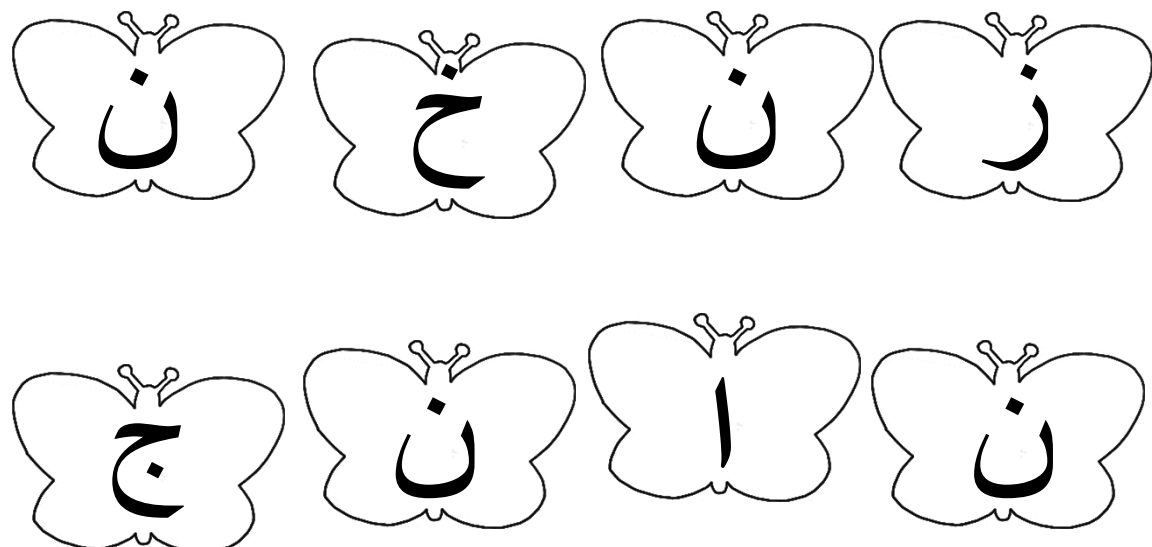

EXERCISE 105: COLOURING EXERCISERECOGNISING LETTERS ن ك TO ل

Colour the picture below according to the letters.

ن	م	ل	ك
Red	Yellow	Black	Orange

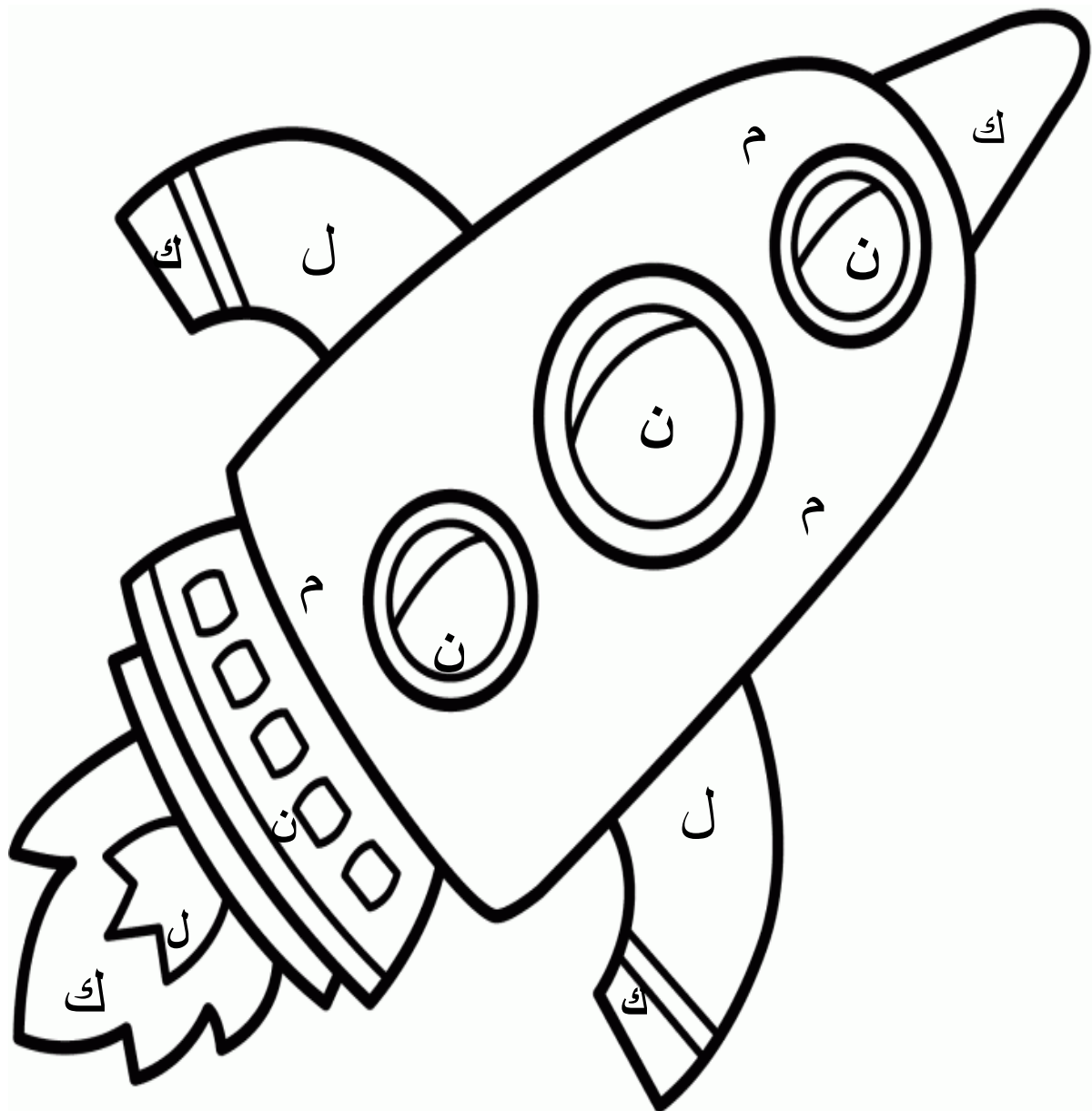

EXERCISE 106: READING EXERCISERECOGNISING LETTERS ن TO ك

Read and identify the alphabets

ن	م	ل	ك
Nun	Mim	Lam	Kaf
ل	ن	م	ق
ك	ف	ل	ش
ع	ن	ك	م
ل	ن	ا	م
ف	ك	غ	د
ق	ل	ك	ا
م	ن	ا	س
ن	م	ا	ز
ك	ل	ن	ك

ن	م	ل	ك
ن	م	ل	ك

EXERCISE 107: COLOURING EXERCISERECOGNISING LETTERS ن ك TO ل

Search for the following letters in the box and colour them

ن	م	ل	ك
Green	Red	Blue	Yellow

ذ	م	ب	ن	ل	ط	ر
ك	ن	س	ص	ف	ج	ث
م	ط	ج	ل	ن	ب	ن
ل	س	ن	ظ	م	ك	ذ
ك	ع	ف	ث	ص	س	ن
ث	ل	ب	ن	ذ	م	ر
ب	ن	ع	ل	ر	ص	ن
م	ث	ك	ف	م	ك	ج

EXERCISE 108: LETTER RECOGNITION

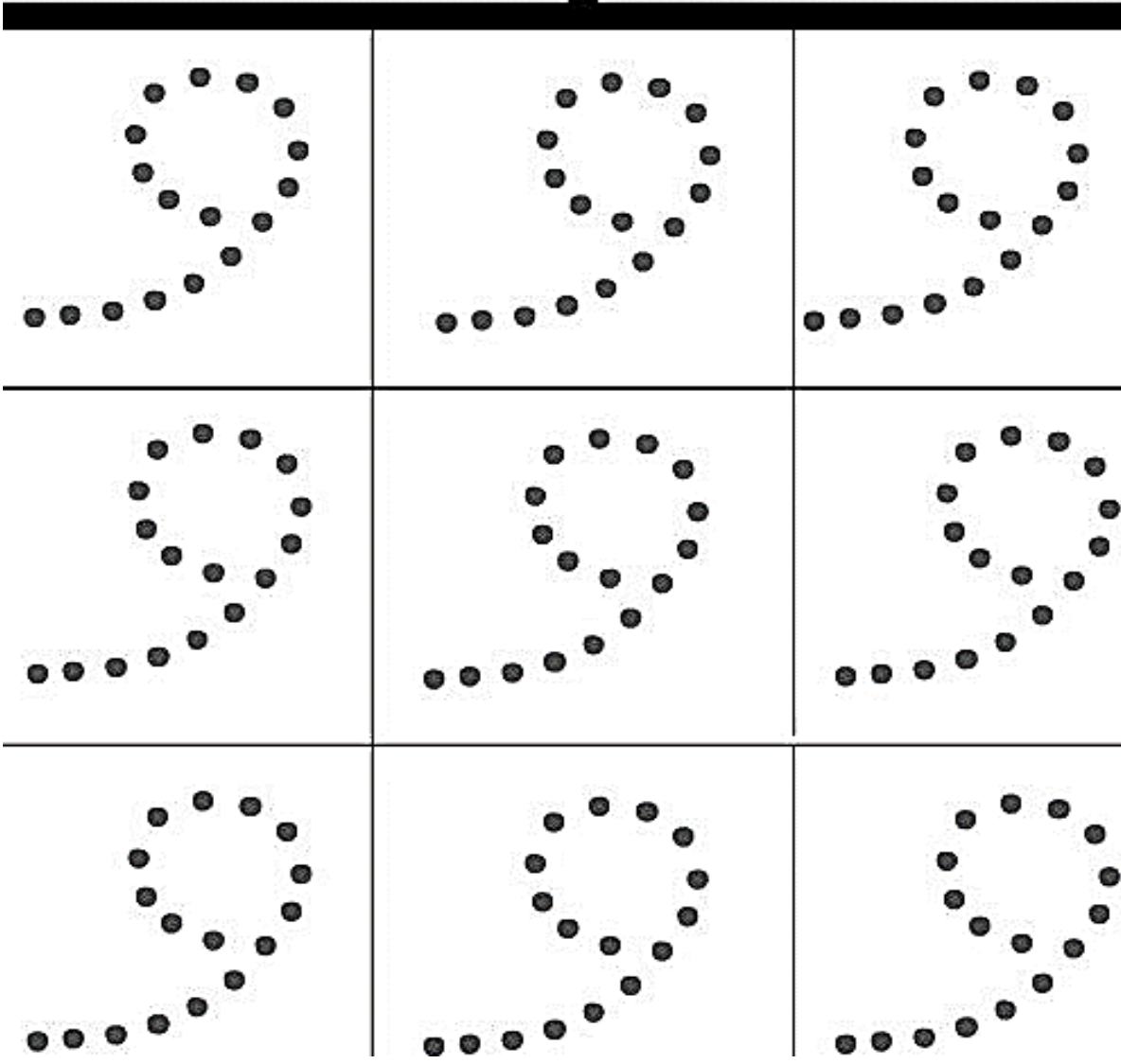
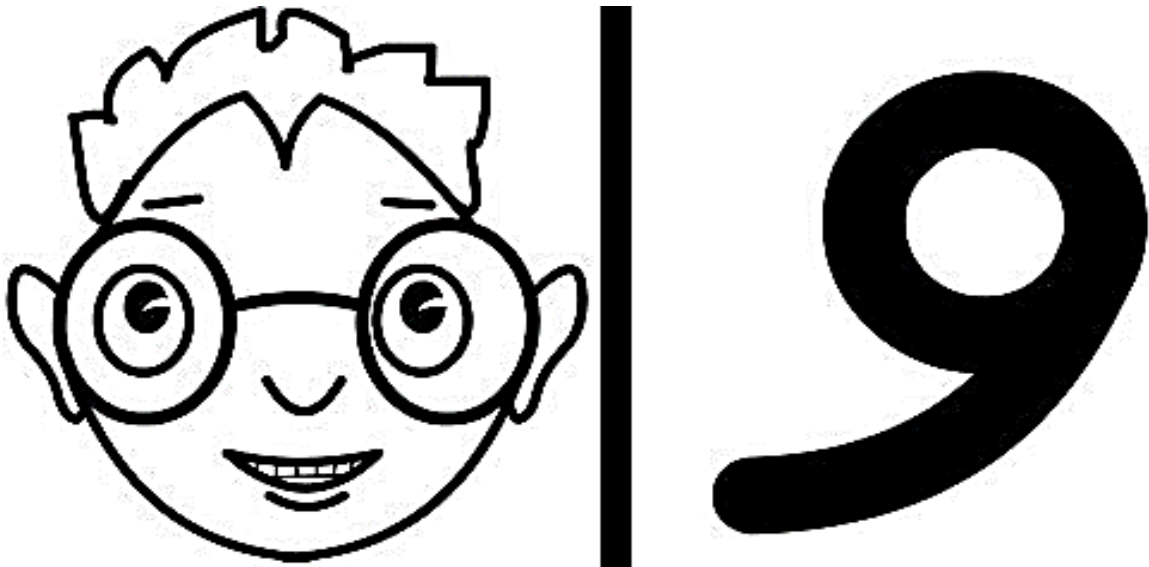

EXERCISE 109: LETTER RECOGNITION

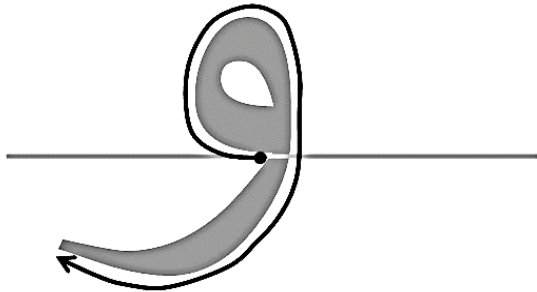

ورد Word

Waw makes the sound 'wo' as in wonder

Read



EXERCISE 110: LETTER RECOGNITION

The image shows a worksheet for letter recognition. At the top, there is a large illustration of a gift box with a ribbon on the left and a large, bold Arabic letter 'Waw' (و) on the right. Below this, there is a 3x3 grid of nine boxes, each containing a dotted outline of the letter 'Waw' for tracing practice.

EXERCISE 111: LETTER RECOGNITION



Ha makes the sound 'ha' as in hat

هدية Hadiyah

Read



EXERCISE 112: LETTER RECOGNITION

Colour only the Shapes which have the letter و

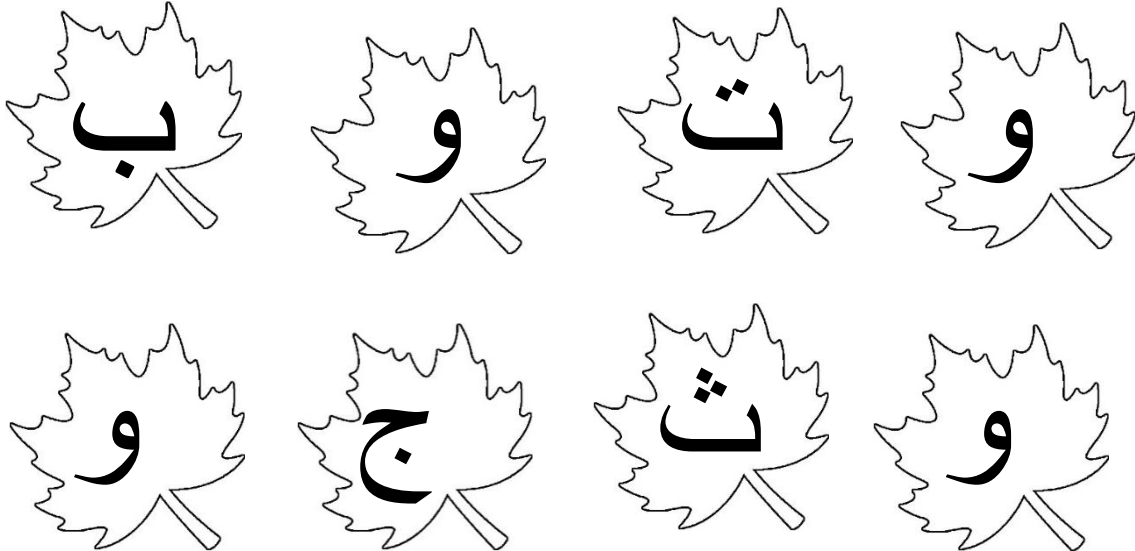
EXERCISE 113: LETTER RECOGNITION

Colour only the shapes which have the letter ه

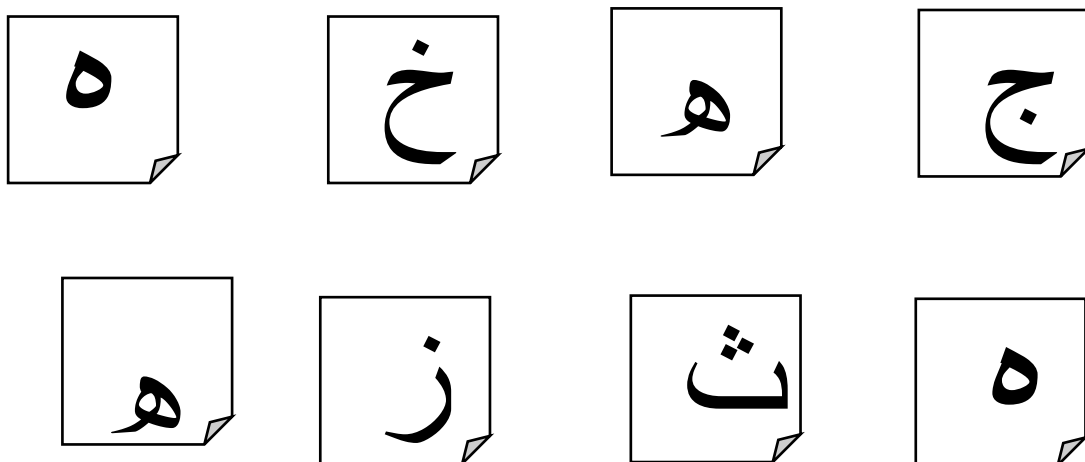

EXERCISE 114: LETTER RECOGNITION

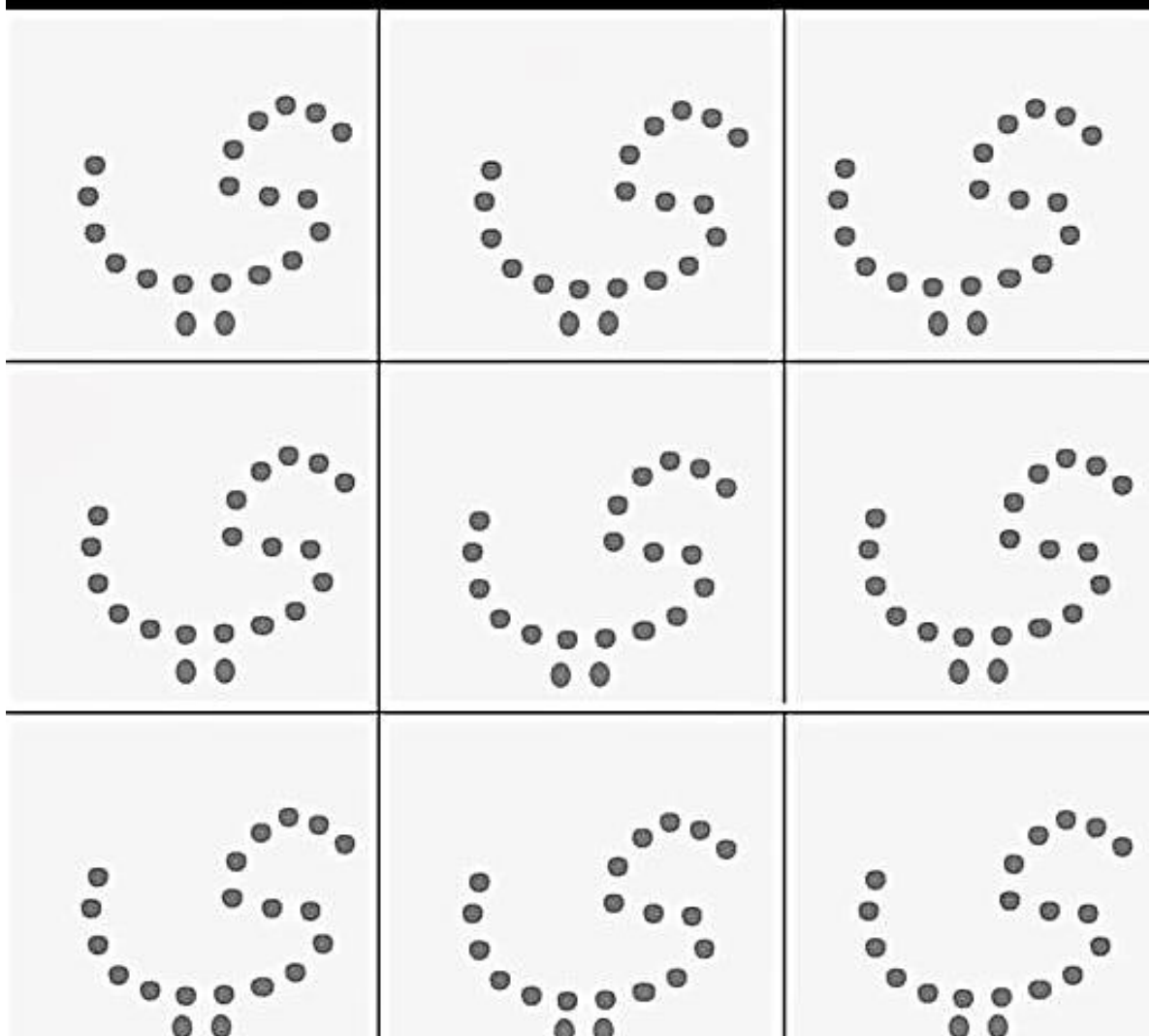
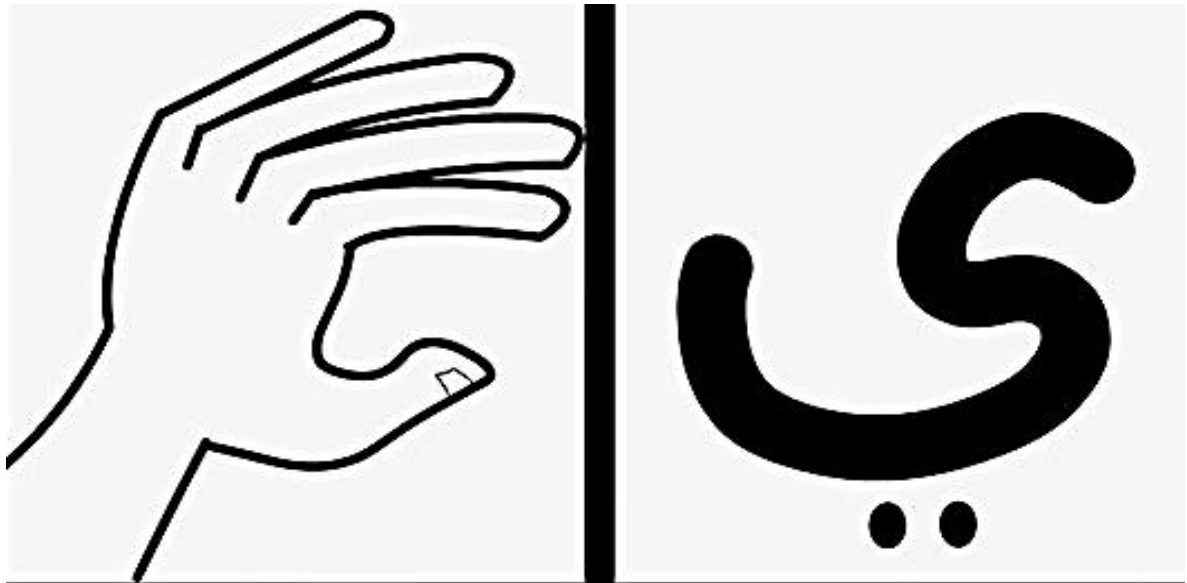

EXERCISE 115: LETTER RECOGNITION

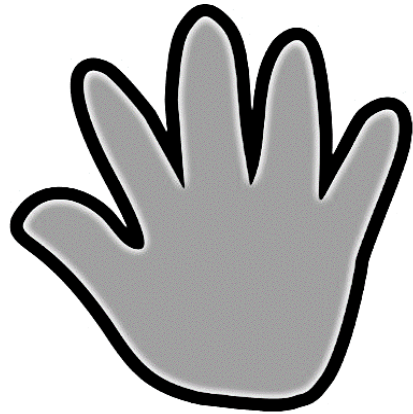

Ya makes the sound 'ya' as in yard

يَدَ Yad

Read

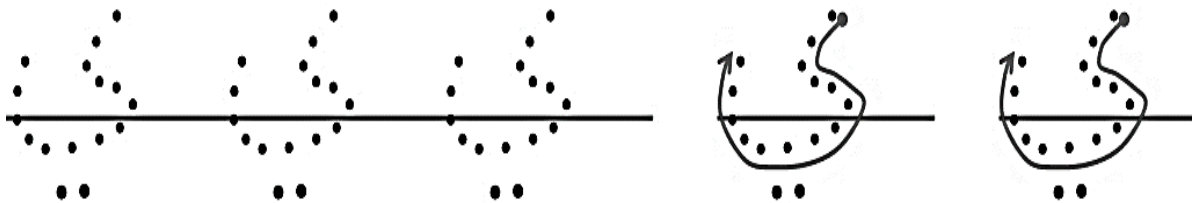

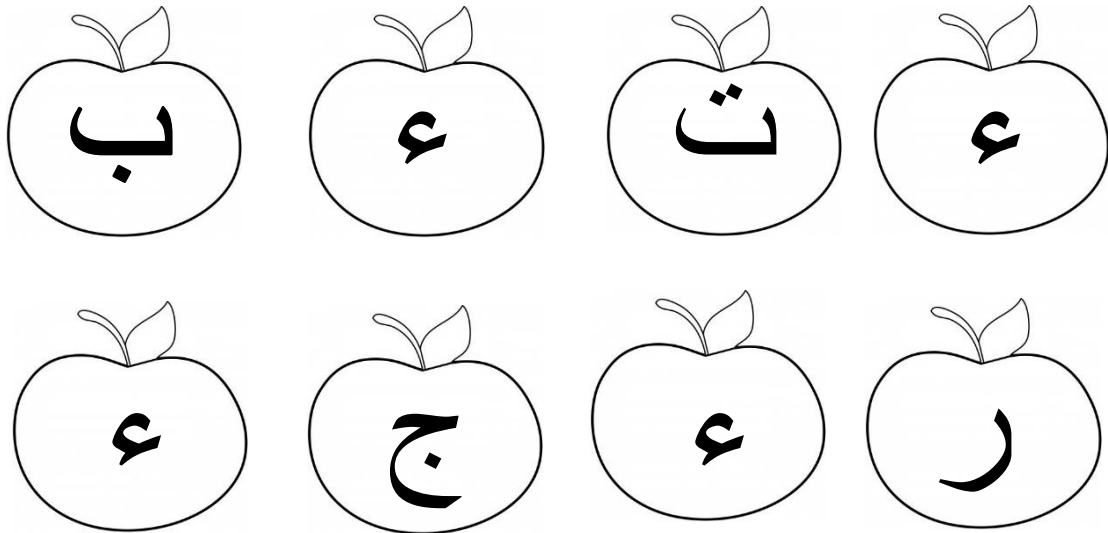
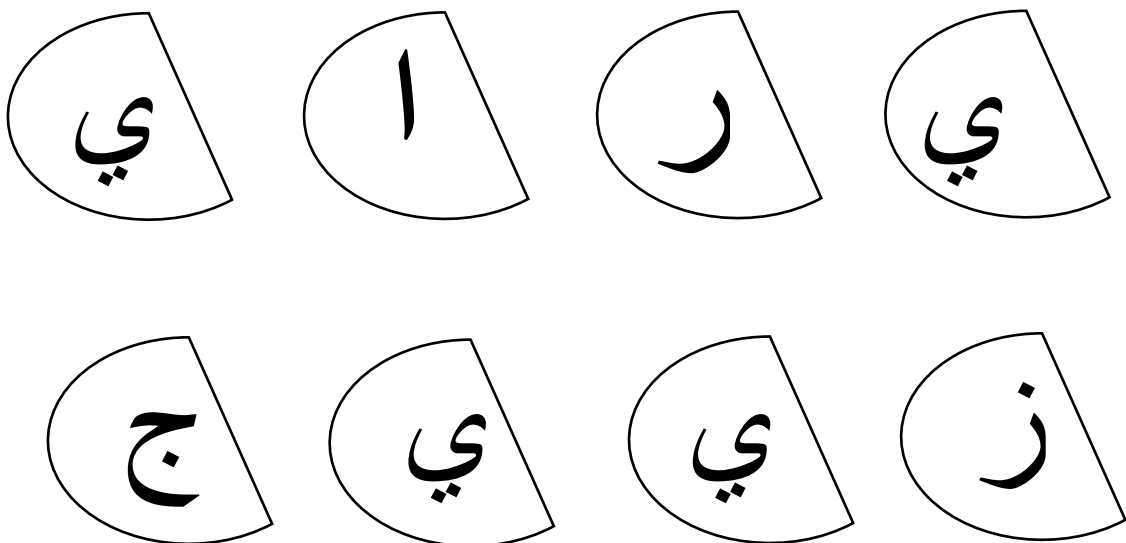
EXERCISE 116: LETTER RECOGNITIONColour only the Shapes which have the letter HamzaRemember the sound of Hamza is the 'a' sound ءEXERCISE 117: LETTER RECOGNITIONColour only the shapes which have the letter ي

EXERCISE 118: COLOURING EXERCISERECOGNISING LETTERS و TO ي

Colour the picture below according to the letters.

ي	ء	هـ	و
Green	Blue	Red	Yellow

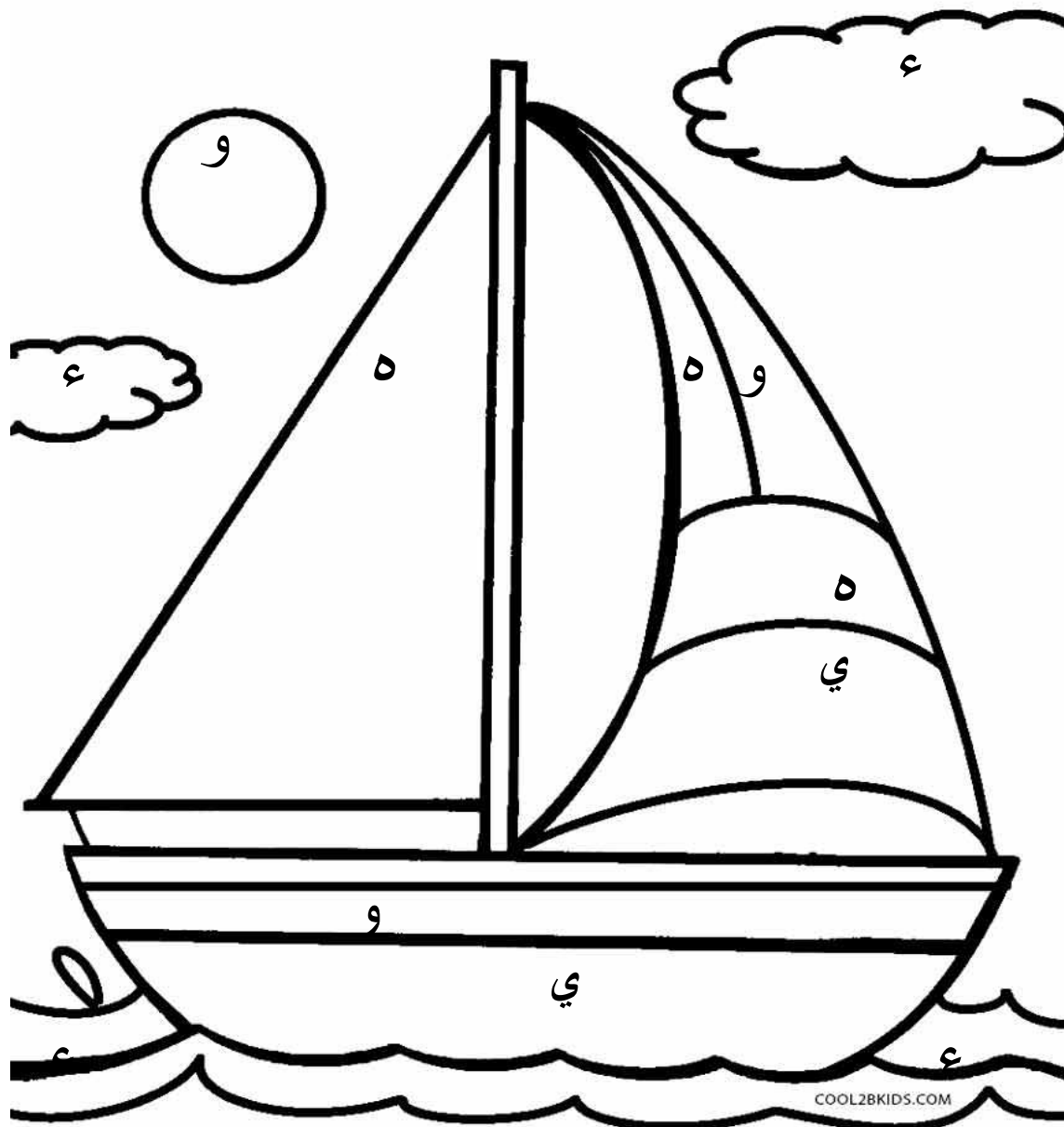

COOL2BKIDS.COM

EXERCISE 119: READING EXERCISERECOGNISING LETTERS ي و TO

Read and identify the alphabets

ي	ء	ه	و
Ye	Hamza	Hai	Waw
ك	ي	ه	م
ع	ي	ن	ء
د	و	غ	ء
ف	س	ا	ك
ء	ي	ل	ز

ي	ء	ه	و
ي	ء	ه	و

ARABIC ALPHABETS CHART (HURUFUL HIJAI)

EXERCISE 120: Join the dots to make the letter

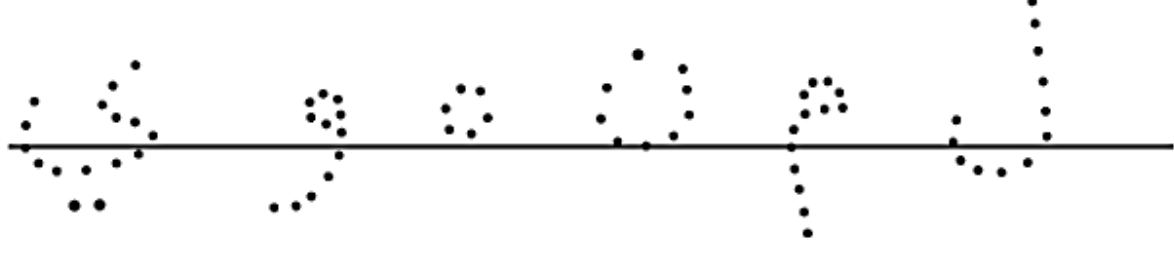
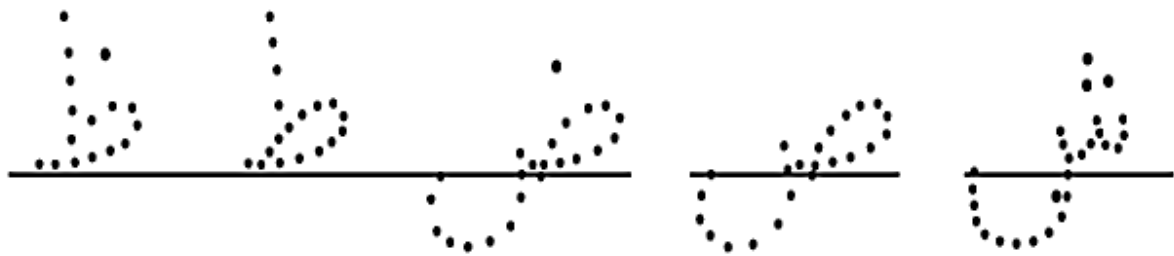
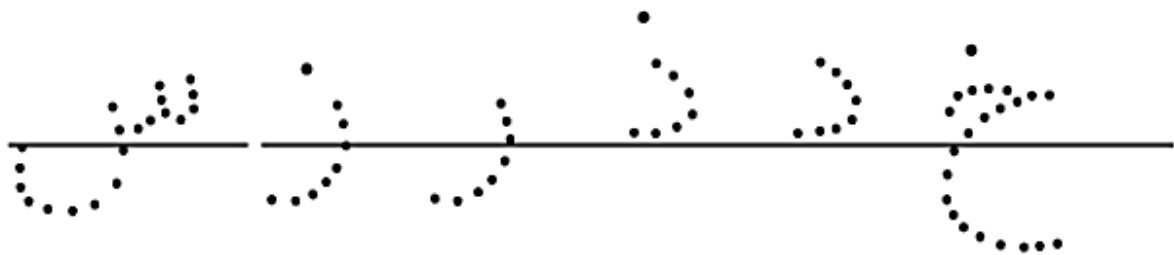

EXERCISE 121: READING ALPHABETS

We have now reached the stage where the student is familiar with all the letters of the Huruful Hijai (The Arabic Alphabet). Revise exercise 121 and 122 to ensure, that the student is fully confident with the letters, before proceeding to the Fat-ha, Kasra and Dhamma.

ض	ه	ث	ق	ا
ح	ر	س	ث	م
ج	ص	د	ف	ء
لا	ظ	غ	ك	س
ل	ذ	ع	ث	ب
و	خ	غ	ه	ي
ط	ه	لا	ن	ز
س	ا	ظ	و	د

EXERCISE 122: READING ALPHABETS

ف	ج	س	ن
ط	ص	ي	و
ك	ف	ث	ه
خ	ذ	ه	ع
د	ز	ث	ظ
ل	ه	ع	ب
لا	و	ن	ض
ا	ث	ر	ح

THE VOWELS IN ARABIC (IRAAB)

FAT-HA, KASRA & DHAMMA (short vowels)

VOWELS THAT GIVE THE SOUND TO THE LETTERS

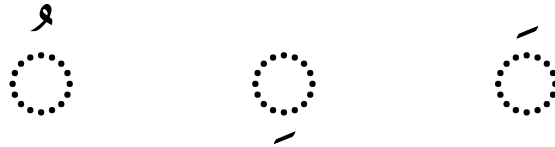

Parent/Teacher's note: Explain to the student about the English vowels, a,e,i,o,u, and how they change the words to sound different, as in bat, sit, put, etc.



Whereas in Arabic the vowels are NOT from the letters, but are in the form of signs, like **Fat-ha**, **Kasra** & **Dhamma**, and by putting them above or below a letter, the sound of the letter changes.

When a child understands the difference between the English and the Arabic, he/she will then have a better understanding of the difference between the two languages.

The 3 major short vowels in Arabic of **Fat-ha**, **Kasra** and **Dhamma** are also known as **IRAAB or HARAKA**. These are the vowels that give the sound to the letters.

When a child has mastered the simple letters, he should be made aware of the vowels (signs, Iraab or Haraka). Explain that, a small line above a letter is called Fat-ha, a similar line below a letter is called Kasra and one with a round turned head (similar to a comma in English) above a letter is called Dhamma.

VOWELS THAT GIVE THE SOUND TO THE LETTERS

FAT-HA	KASRA	DHAMMA
		
BA	BI	BU

Write the Iraab (sign) of Fat-ha, Kasra and Dhamma on the board and show the child the signs, explain to them how the sound of the letter changes, when the position of the sign is changed. Allow enough practice of how to pronounce the letters which bear signs.

Fat-ha: While uttering a letter bearing a Fat-ha, the mouth should be opened upwards.

Kasra: While uttering a letter bearing Kasra, the voice should come out of the mouth straight and the lower jaw should incline a little downwards.

Dhamma: As regards to a letter bearing the Dhamma sign, it should be uttered by protruding the lips a little and keeping them in a round shape.

Note that these IRAAB, are original sounds in Arabic, that assist you to read and pronounce the letter properly.

The teacher should pronounce every letter of the alphabet herself and then make the students repeat them.

بَ	ba
تَ	ta
جَ	ja

In other words instead of resorting to spellings, the letters bearing the vowels should be read out in a running manner.

This is a basic introduction. In the next section, we individually introduce each Iraab in detail, followed by some practical reading and writing exercises. These will help in consolidating what the child has learnt.

It is better to introduce the Iraab one at a time so that the student becomes fully conversant with each, THEN move forward to the next one. This will build his/her confidence and you can encourage them by saying that they are now able to join and read words in Arabic.

THE SHORT VOWEL FAT-HA



(a) FAT-HA  is a small slanting line placed above the letter and it gives that letter the sound of 'a' while reading.

EXERCISE 123: READING FAT-HA PRACTICE

جَ	ثَ	تَ	بَ	أَ
ja	tha	ta	ba	a
رَ	ذَ	دَ	خَ	حَ
ra	dha	da	kha	ha
ضَ	صَ	شَ	سَ	زَ
dha	ssa	sha	sa	za
فَ	غَ	عَ	ظَ	طَ
fa	gha	a	zha	tta
نَ	مَ	لَ	كَ	قَ
na	ma	La	ka	Qa
		يَ	هَ	وَ
		ya	ha	wa

FAT-HA WRITING PRACTICE ALPHABETICALLY

EXERCISE 124: Put in the Fat-ha sign on these letters.

Remember the Fat-ha sign is a small slanting line placed above the letter. It is pronounced with the sound 'a'.

Say the sounds as you put in the Fat-ha sign. Example a, ba , ta , etc. Two examples have been done for you.

ج	ث	ث	بَ	أَ
ر	ذ	د	خ	ح
ض	ص	ش	س	ز
فا	غ	ع	ظ	ط
ن	م	ل	ك	ق
	ي	ء	ه	و

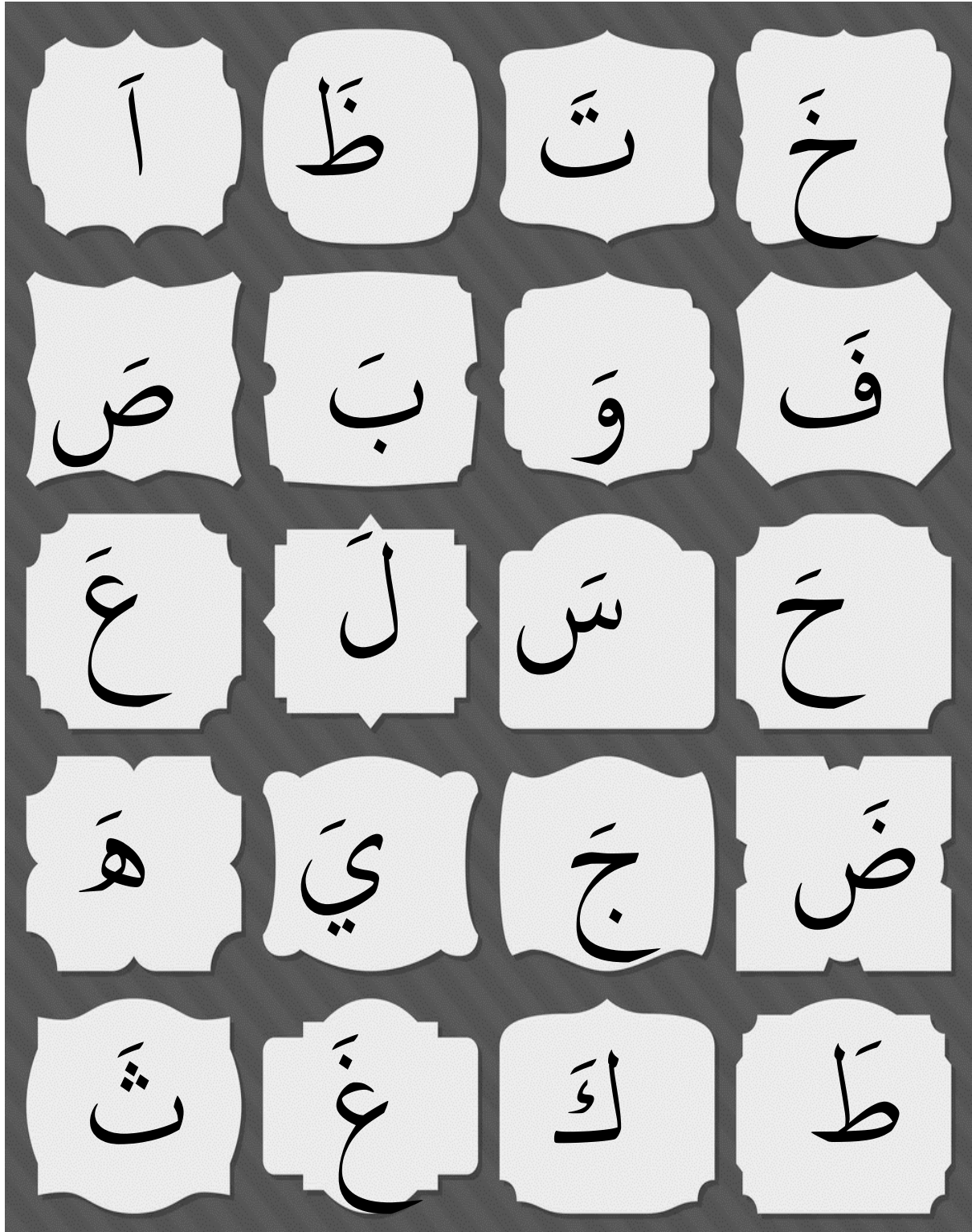
FAT-HA PRACTICE - SINGLE LETTERS (MIXED)**EXERCISE 125: READ AND IDENTIFY**

FAT-HA PRACTICE - SINGLE LETTERS

EXERCISE 126: READ AND IDENTIFY

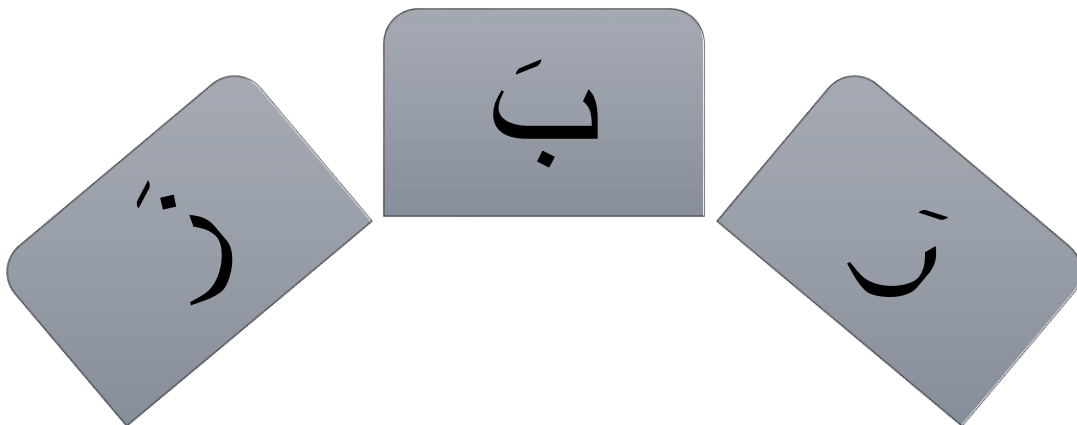
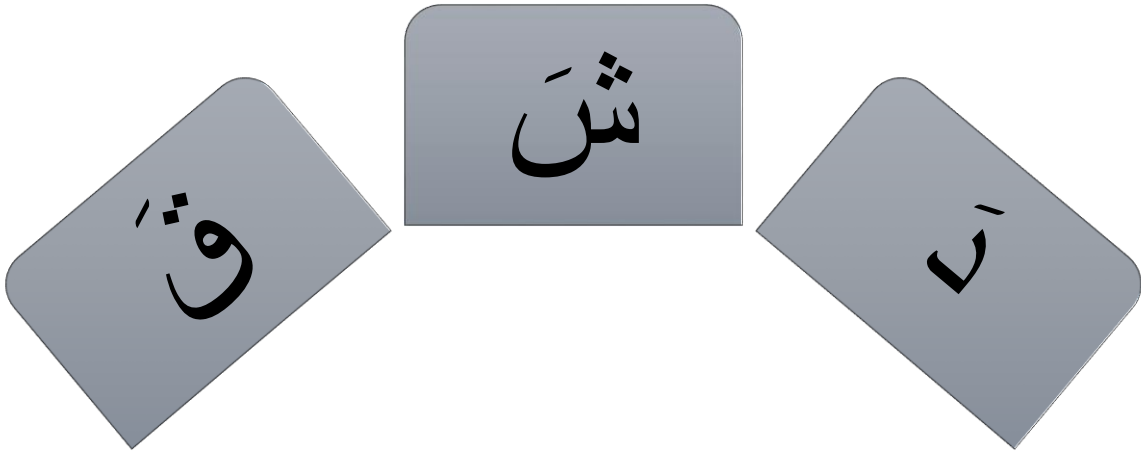

FAT-HA PRACTICE - TWO LETTERS

EXERCISE 127: READ AND IDENTIFY

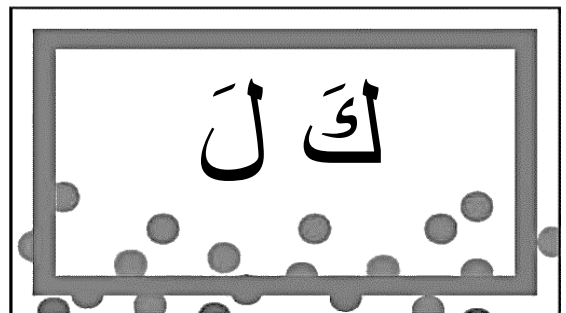
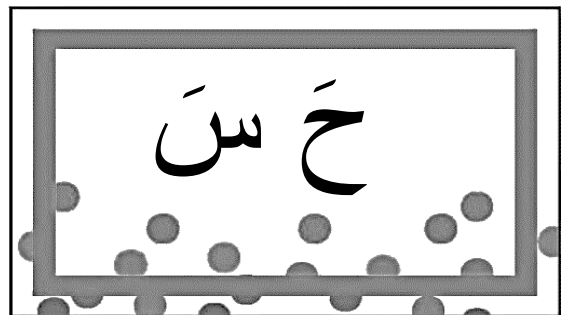
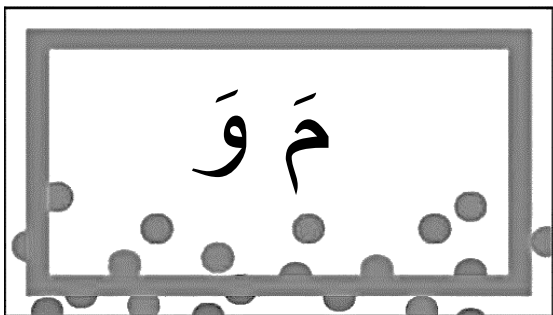
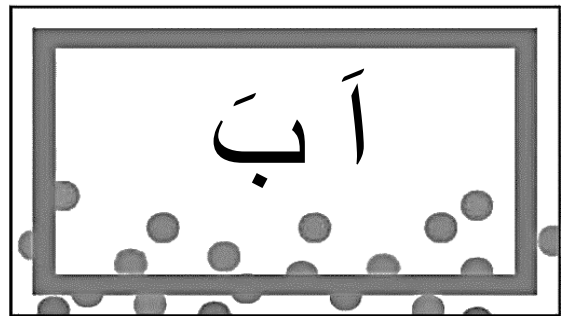
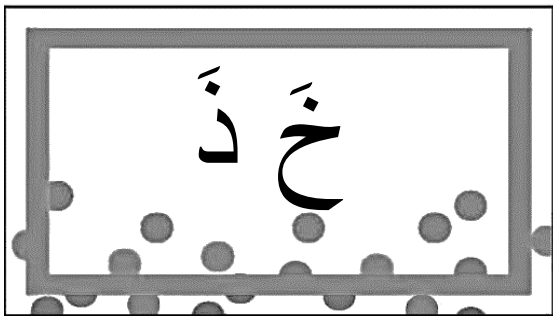
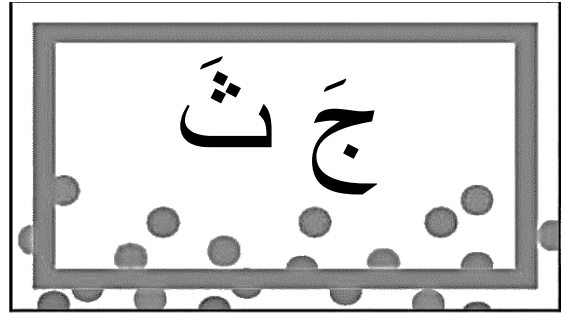
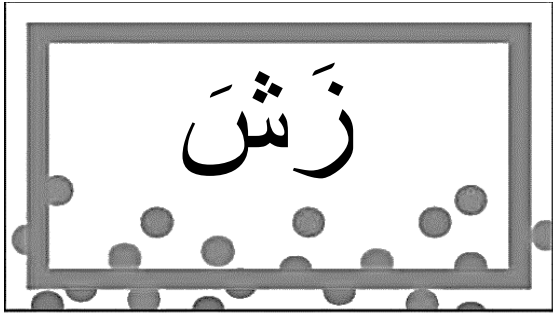

FAT-HA PRACTICE - TWO LETTERS

EXERCISE 128: READ AND IDENTIFY

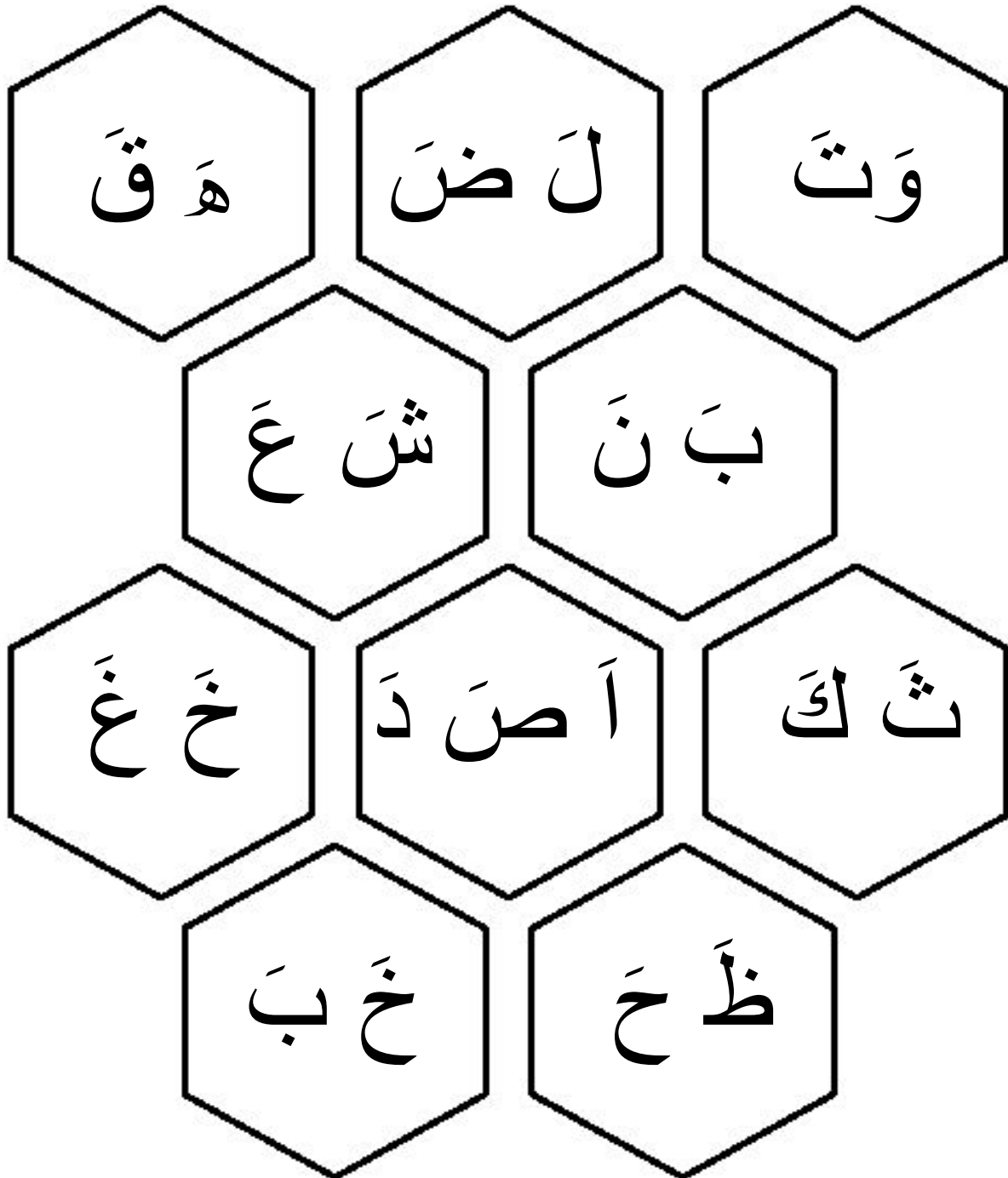

FAT-HA PRACTICE - TWO AND THREE LETTERS**EXERCISE 129: READ AND IDENTIFY**

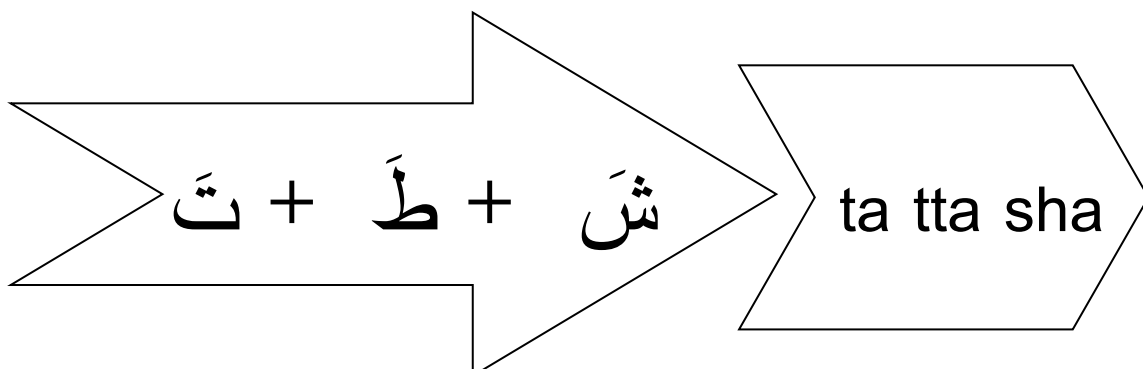
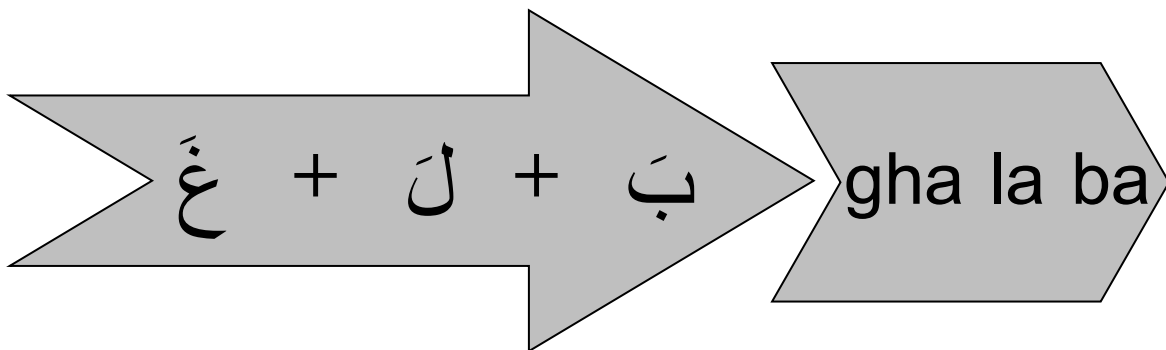
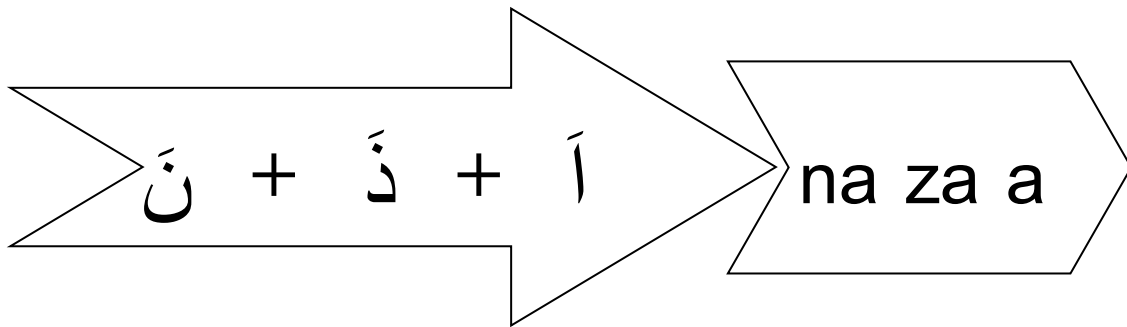
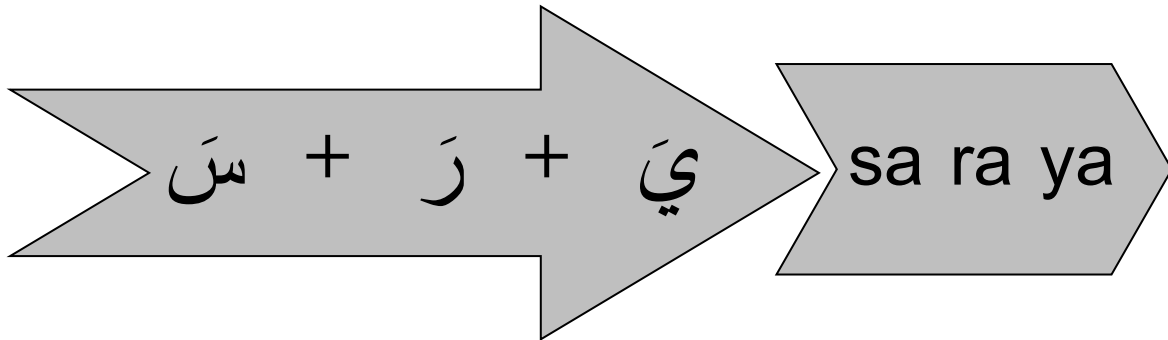
FAT-HA READING PRACTICE**EXERCISE 130: READ AND IDENTITY THE LETTERS**

FAT-HA PRACTICE - THREE LETTERS
EXERCISE 131: READ AND IDENTIFY

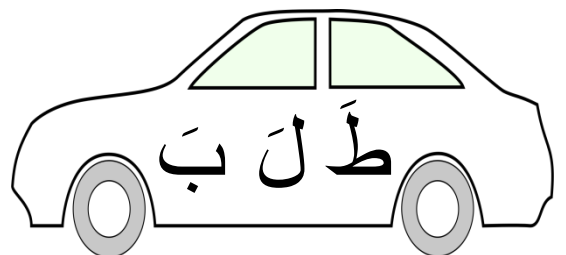
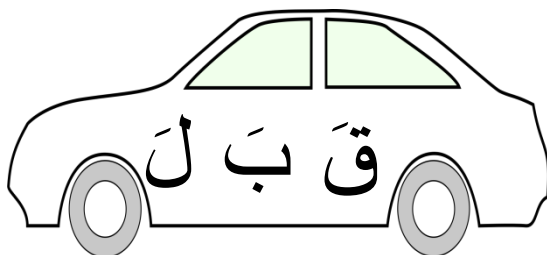
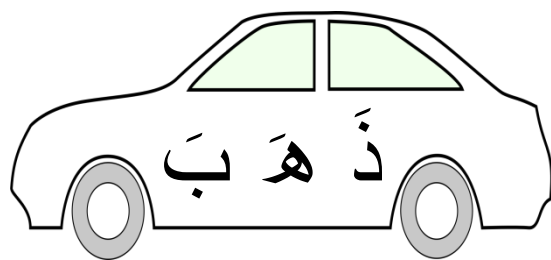
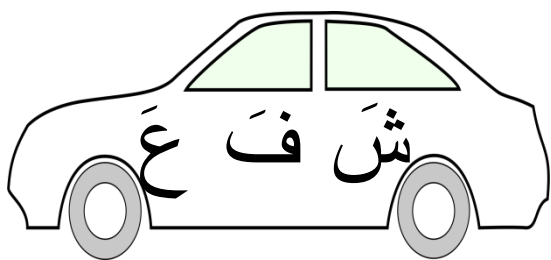
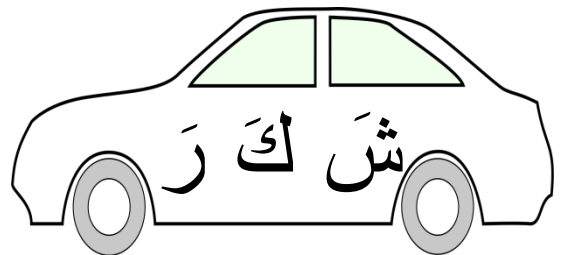
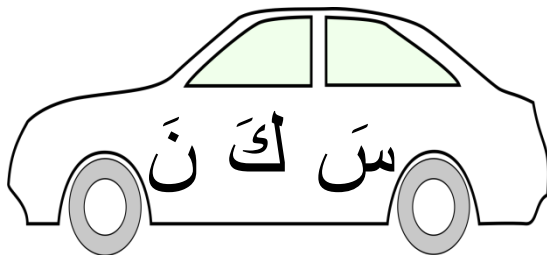
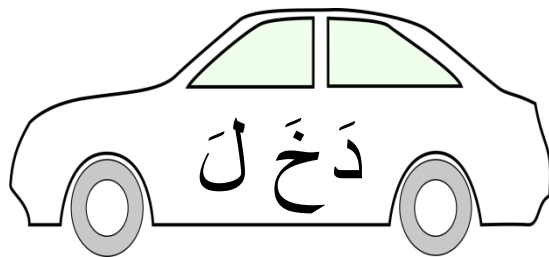
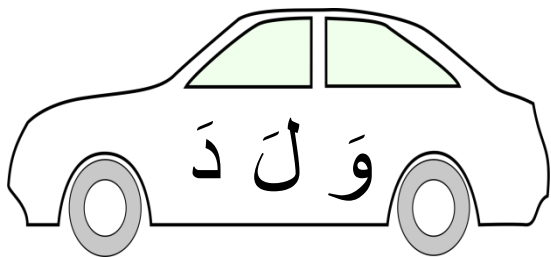
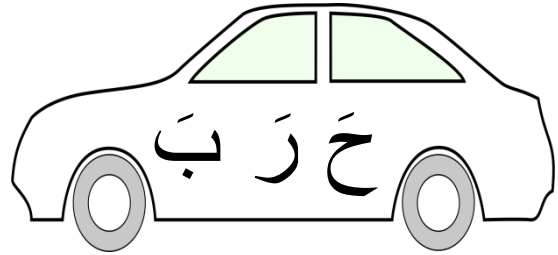
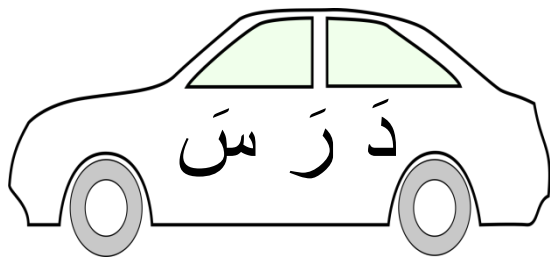

FAT-HA PRACTICE - THREE LETTERS**EXERCISE 132: READ AND IDENTIFY**

FAT-HA PRACTICE - THREE LETTERS**EXERCISE 133: READ AND IDENTIFY**

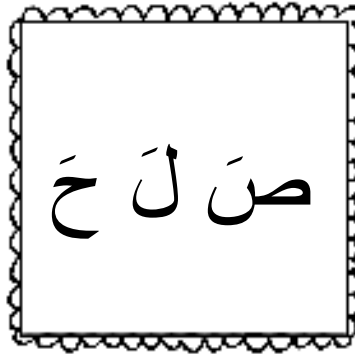

بَ صَ رَ



صَ لَ حَ

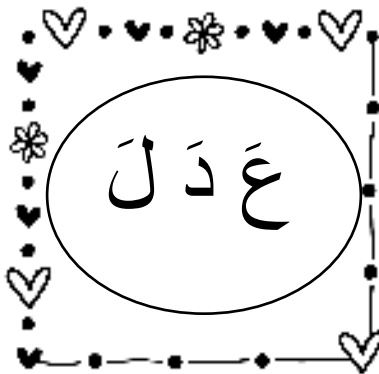

حَ طَ بَ



عَ دَ لَ

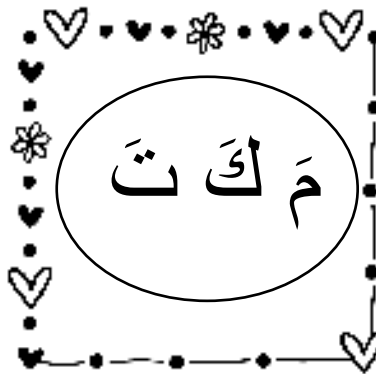

مَ كَ تَ

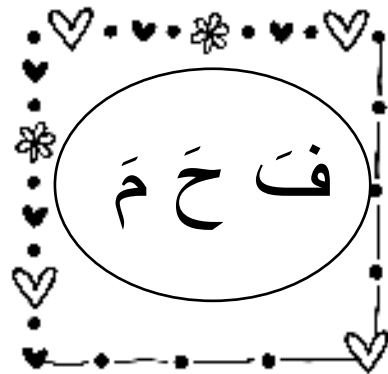

فَ حَ مَ



ضَ رَ بَ



قَ مَ رَ

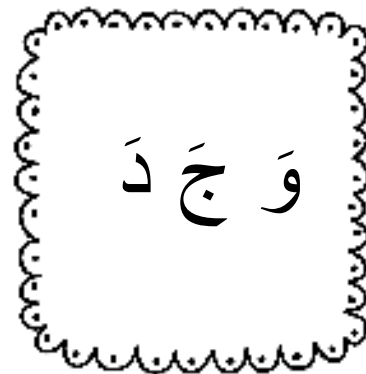

وَ جَ دَ



نَ هَ رَ









ظَ لَ مَ



سَ رَ فَ

FAT-HA PRACTICE - FOUR LETTERS**EXERCISE 134: READ AND IDENTIFY**

FAT-HA PRACTICE**EXERCISE 135: READ AND IDENTIFY**

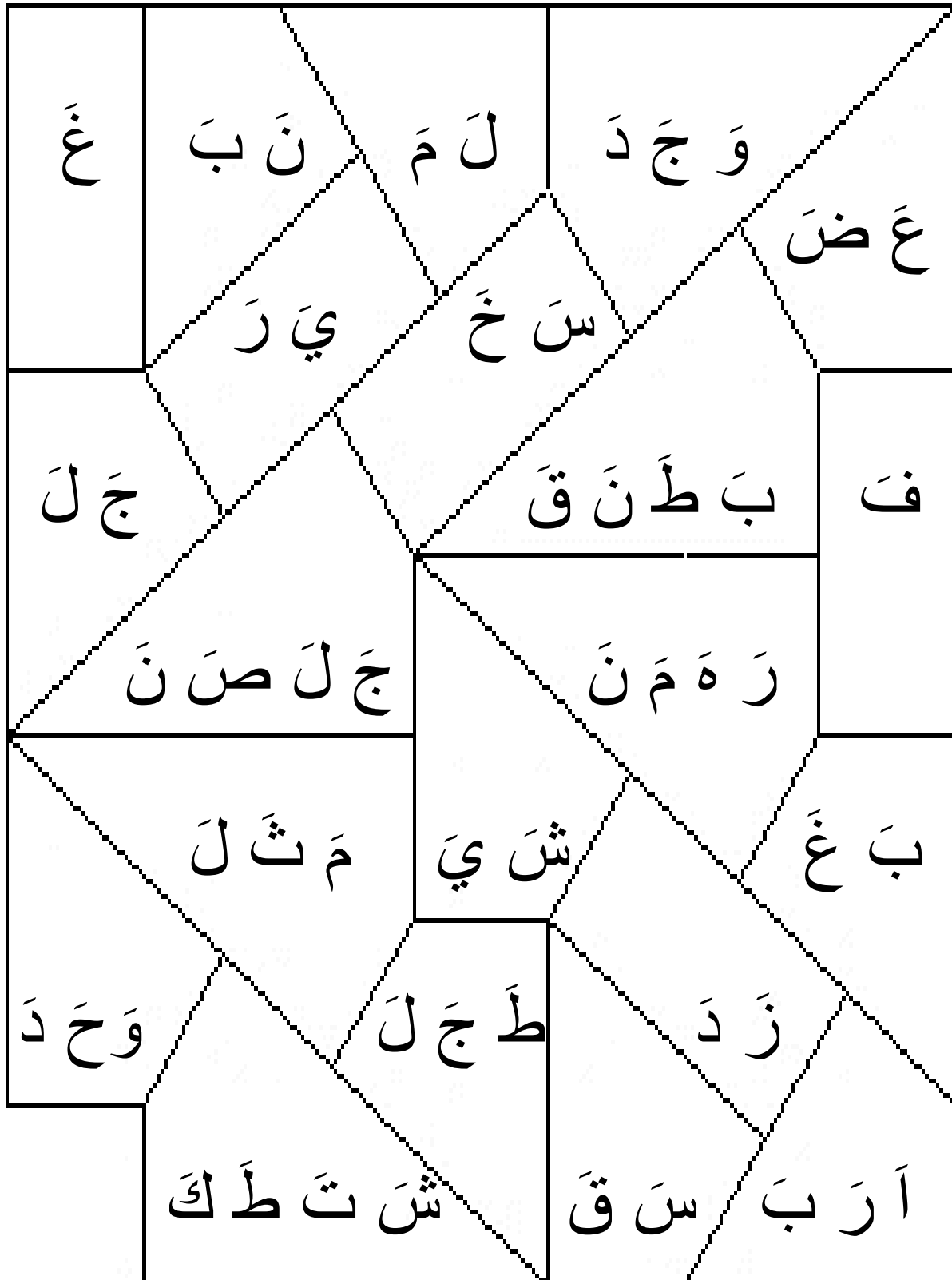
THE SHORT VOWEL KASRA ◌ِ

(b) **KASRA** ◌ِ is a small slanting line below the letter, and it gives that letter, the sound of 'i' while reading.

EXERCISE 136: KASRA READING PRACTICE

جِ	ثِ	تِ	بِ	اِ
Ji	Thi	Ti	Bi	i
رِ	ذِ	دِ	خِ	حِ
Ri	Dhi	Di	Khi	Hi
ضِ	صِ	شِ	سِ	زِ
dhi	Ssi	Shi	Si	Zi
فِ	غِ	عِ	ظِ	طِ
Fi	Ghi	i	zhi	tti
نِ	مِ	لِ	كِ	قِ
Ni	Mi	Li	Ki	Qi
	يِ	ءِ	هِ	وِ
	Yi	i	Hi	Wi

KASRA WRITING PRACTICE

EXERCISE 137: Put in the Kasra sign on these letters.

Remember the Kasra sign is a small slanting line placed below the letter. It is pronounced with the sound 'i'

Say the sounds as you put in the Kasra sign. Example i, bi , ti , etc. Two examples have been done for you.

ج	ث	ت	بِ	اِ
ر	ذ	د	خ	ح
ض	ص	ش	س	ز
ف	غ	ع	ظ	ط
ن	م	ل	ك	ق
	ي	ء	ه	و

EXERCISE 138: READING KASRA LETTERS



EXERCISE 139: READING KASRA LETTERS

رِ	سِ	عِ	فِ	نِ
كِ	قِ	لِ	طِ	
دِ	بِ	تِ	ظِ	
اِ	هِ	جِ	يِ	نِ

EXERCISE 140: READING KASRA LETTERS

جِ ثِي

Ji Thi



جِ بِي

Ji Bi



جِ ثِي



جِ بِي



جِ اِي



جِ بِي



جِ سِي



جِ ثِي



EXERCISE 141: READING KASRA LETTERS

مِ وِ	طِ قِ
كِ نِ	نِ يِ
صِ عِ	ضِ غِ
قِ لِ	هِ فِ

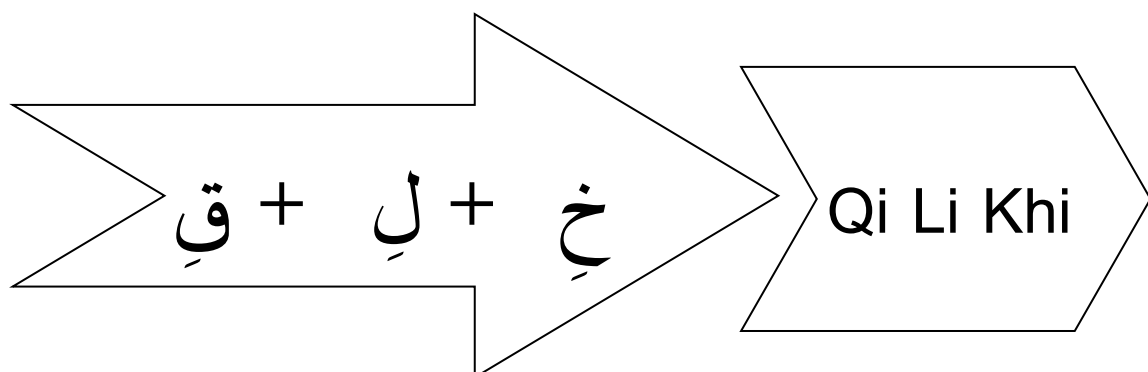
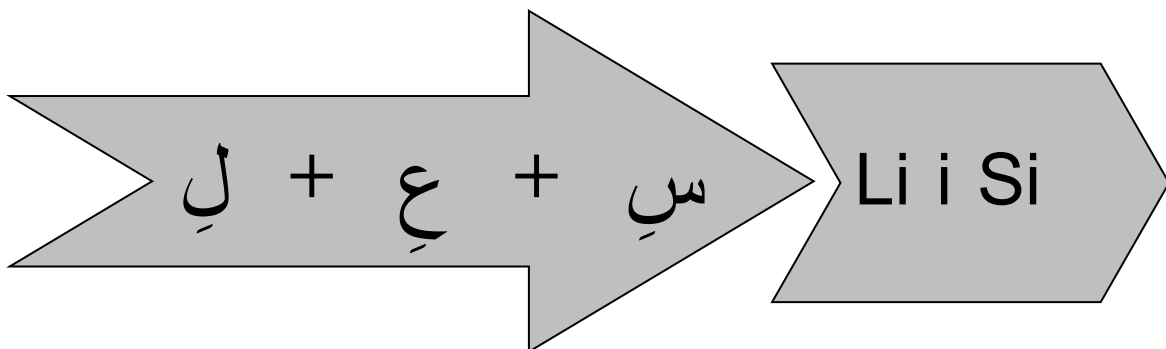
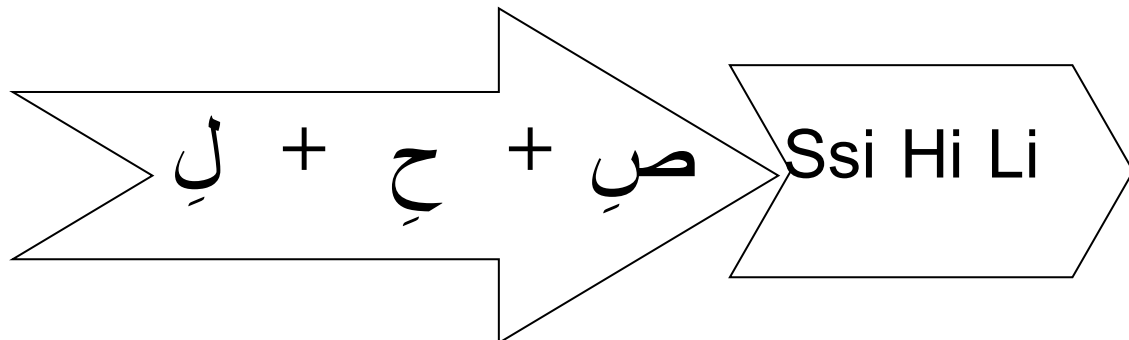
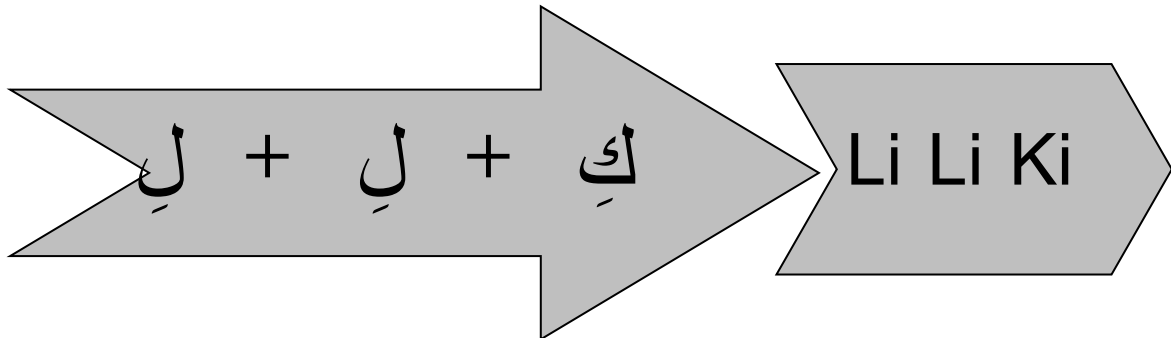
KASRA READING PRACTICE**EXERCISE 142: IDENTIFY AND READ**

EXERCISE 143: KASRA READING PRACTICE

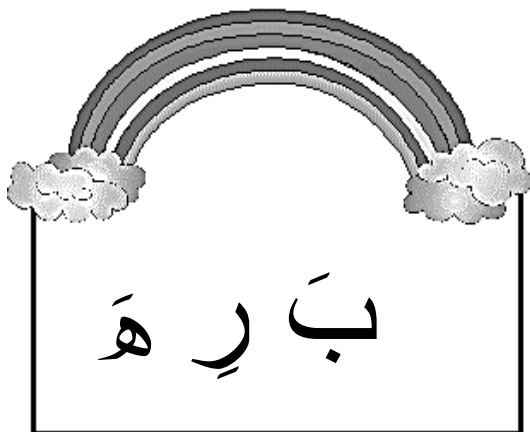
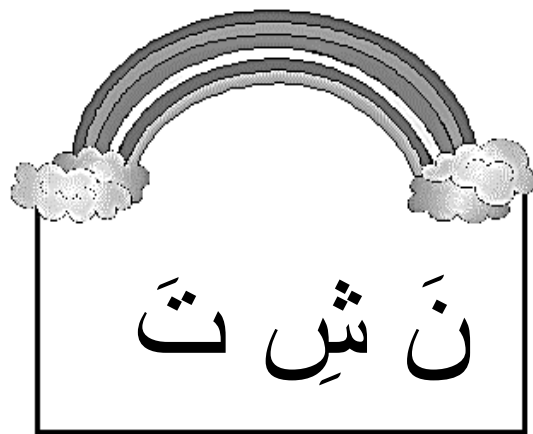

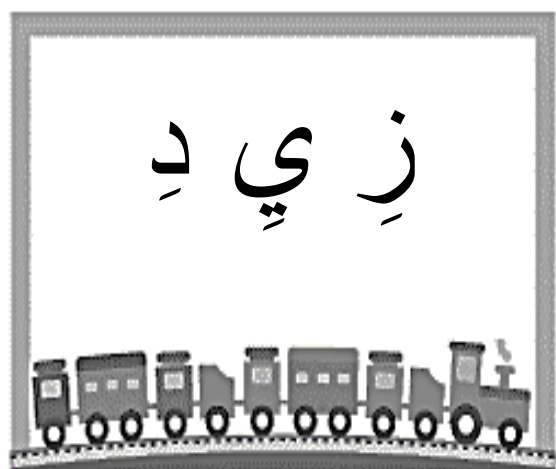
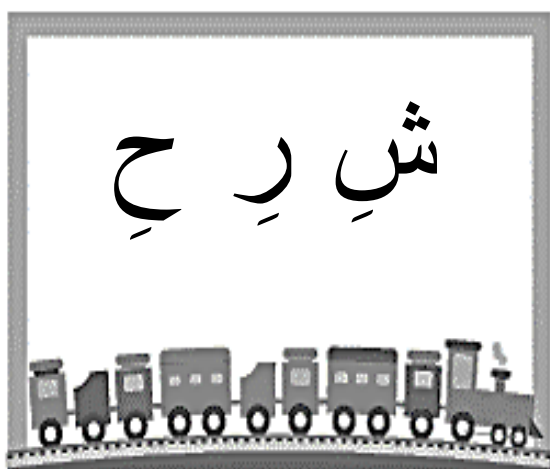
EXERCISE 144: KASRA READ AND IDENTIFY

EXERCISE 145: FAT-HA AND KASRA READING

حِ سِ بَ

لِ بِ ثَ

ظِ هِ فِ

نِ سِ يِ

عِ كِ بَ

وِ رِ ثَ

EXERCISE 146: FAT-HA AND KASRA READING

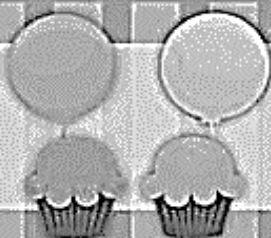

لَا رِيبَ لَنَا



لَا رِيبَ لَنَا



لَا رِيبَ لَنَا



لَا رِيبَ لَنَا



لَا رِيبَ لَنَا



لَا رِيبَ لَنَا

EXERCISE 147: KASRA READING

لِ بِ اِ

فَا رِ جِ

فَا رِ سِ

رِ نِ ثِ

رِ تِ سِ

ثِ تِ بِ

كِ رِ فَا

لِ مِ عِ

مِ تِ ظِ

لِ ثِ فِ

EXERCISE 148: READ AND IDENTIFY

WHAT WE HAVE LEARNT IN CLASS 2

THE HURUFUL HIJAI (THE ARABIC ALPHABET) and THE IRAAB SIGNS OF FAT-HA and KASRA

All the sounds covered so far have been put together into the next exercises. Make sure all the sounds are pronounced correctly. Repeat these exercises as many times as necessary to improve understanding, fluency, makharij and confidence of the student.

Teacher/ Parent Note: Exercise 148 brings us to the end of the Syllabus for Class Two. Try the Exercises 149 - 153 below and test the student to see if they have grasped all that has been taught so far. Congratulate the student on this big achievement and encourage them to aim higher.

Please ensure that the child is completely sure and can recognize all the letters, before proceeding to the next level.

EXERCISE 149: READING PRACTICE

هَ	كَ	خَ	ثَ	صَ	بَ
ثَ	هَ	لَ	حَ	نَ	وَ
جَ	دَ	لَ	كَ	شَ	أَ
اِ	لِ	شِ	قِ	كِ	بِ
حِ	ذِ	صِ	فِ	خِ	هِ
تِ	مِ	زِ	نِ	طِ	غِ

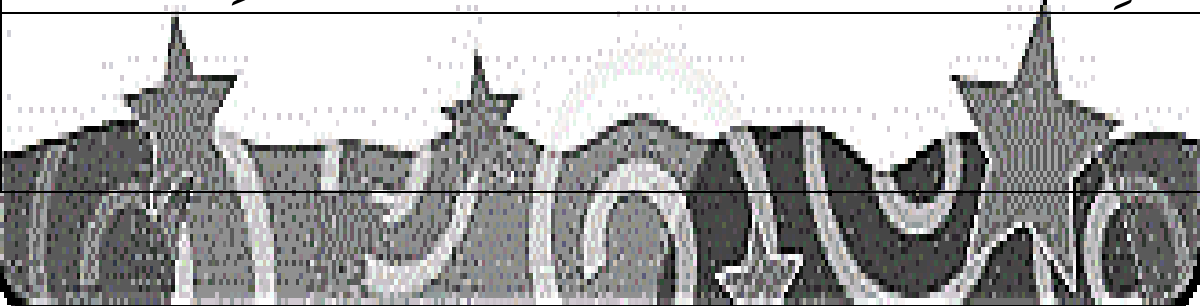

EXERCISE 150: READING PRACTICE

م	فِ	شِ	لِ	صِ	غِ
لَا	جِ	بِ	فِ	نَ	وَ
عَ	جَ	رَ	جَ	تَ	بَ
مَ	قَ				
خِ	نِ	صَ	لَ	مَ	نَ
غَ	تَ	سَ	رَ	كَ	بَ
لِ	كِ	لِ	مِ	لِ	لِ
دِ	لِ	عِ	جِ	هِ	خِ
فَ	هَ	ذَ	مِ	لِ	سِ
لِ	أَ	سَ	رَ	شَ	عَ

EXERCISE 151: FAT-HA AND KASRA READING

جَ كَ لَ ةَ

فَ ةَ نَ سَ

كَ رَ ذِي

مَ رَ ضَ وَ

نَ هَ عَقَ

كَ دَ صَ

لَ هَ ثَ مَ

خَ ثَ دَ خَ

EXERCISE 152: FAT-HA AND KASRA READING

قِ بِلِ	صِ حِنِ	جِ بِلِ
سِ كِةِ	مِ صِ دِ	كِ مِلِ
غِ شِ يِ	بِ يِ دِ كِ	قِ بِ رِ تِ
خِ لِ قِ كِ	وَلِ يِ	عَ دَلِ كَ
وِ فِ	رِ زِ كِ	كِ لِ
بِ قِ يِ	مِ شِ خِ	أَكِ تِ

EXERCISE 153: FAT-HA AND KASRA READING

فَ رِ ضَ طَ

شَ رِ كَ تَ

مَ دِ نَ تَ

وَلَ دِ قَ

لَ بِ ثَ كَ

لِ كَ دَرَ

خَ لَ قِ كَ

وَجَ ذِرَ



