



HAYDARI MADRASAH
(NAIROBI)

QUR'AN READING

CLASS KG

(Age 3 yrs)

Name: _____



HAYDARI MADRASAH
(NAIROBI)

QUR'AN READING

CLASS KG - Age 3 yrs

NO COPYRIGHT

September, 2020

These manuals on Qur'an reading, have been prepared to especially assist parents, teachers and students, who wish to teach and/or learn to recite the Holy Qur'an.

Please note that there is **NO COPYRIGHT** in regards to the reproducing of these manuals as long as the aim above is being fulfilled. Therefore there is **NO** requirement of a written permission from Haydari Madrasah Nairobi for reproducing this book for Madaris or personal use.

In case only part of this manual is reproduced, or the material therein edited in any manner, we request that any and all references to Haydari Madrasah Nairobi, be removed.

We do request however, that the manuals reproduced should **NOT** be for profit / commercial purposes. The cost of reproducing this manual may be recovered.

Qur'an Reading Department
Haydari Madrasah (Nairobi)
hmn@saaj.co.ke

CONTENTS: Qur'an Reading Syllabus

<u>SUBJECT</u>	<u>DETAILS</u>	<u>PAGE</u>
Surahs Memorisation <u>Class KG</u>	Surah Al-Fatehah (Surah No: 1) Surah Al-Ikhlās (Surah No: 112) Surah Al-Asr (Surah No: 103) Surah Al-Kawthar (Surah No: 108)	7 8 9 10
Kalema	Recitation of full Kalema with meaning	11
Dua e Faraj	Dua for the safety of our 12 th Imam	12
Short Duas <u>KG</u>	Dua for Knowledge Dua for being Kind	13 14
Islamic Phrases	Islamic Phrases and what they mean: Bismillah, Salaam/Wa Alaikum Salaam, Shukran, Jazakallah, Alhamdulillah, MashaAllah, Afwan, Salawaat	15 - 18
The Holy Qur'an	How Allah's Message came to us	19

CONTENTS: Syllabus for Class KG.....continued

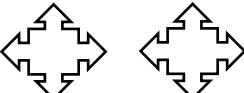
<u>SUBJECT</u>	<u>DETAILS</u>	<u>PAGE</u>
The Holy Qur'an	How to Respect the Special Book	20
Motor Control	Motor Control Activities	21 - 31
First 10 Letters	Introduction to the First 10 letters	32 - 34
Alif, Be, Te and The	Individual introduction + Reading & Written Activities	35 - 57
Jim, Hai and Khai	Individual introduction + Reading & Written Activities	58 - 76
Dal, Dhal and Re	Individual introduction + Reading & Written Activities	77 - 95
Revision	What we have learnt in Class KG	96 - 108
Certificate	Congratulations you did it 	109

SURAHS MEMORISATION - from KG to CLASS 3

The Holy Prophet (SAW) has said:

"The number of levels (stages) in Heaven is (equivalent to) the number of verses in the Qur'an (6236). Thus, when a reciter of the Qur'an enters into Heaven, it will be said to him: 'Go up one level for every verse that you can recite.' Thus, none will be in a higher level than the one who has memorized the entire Qur'an."

[Biharul Anwar, Volume 92 Page 22]

The table below classifies how the student will be tested for Surah Memorisation every year, by the Holy Madrasah. It will be to the child's advantage if parents prepare them ahead of time.

The chart from KG to Class 12 has been designed to cover the whole of the 30th Sipara (Juz Amma).

Some surahs have been repeated for testing purposes. Surahs which are required in our day to day lives, like Surah Jumuah and Surah Mulk have been added.

Parents are advised to train their child(ren) to memorise by reading from the Qur'an rather than only learning the Surah by heart.

When the child reads then memorizes, they learn the formation of the text, and they learn where the extra pull is required. It also ingrains the Surah well into their minds.

EFFECTIVE METHODS OF MEMORISATION

- 1) Teach an Ayah a day. This is a tried and tested method, where even when the student is ready to learn more, we restrain and teach only that one ayah (with meaning if one prefers). The next day a second ayah and so on. In a week the student has learnt 7 ayaat. This is stress free and an easy method.
- 2) Get help from YouTube. Type in the Surah Name and numerous options will come up. You can select your preferable reciter (we recommend Mishary Al Afasy) and the student can listen, read and learn at the same time. This will help build in, the right makharij as well.
- 3) Download the App called Memorize. This is preferred by the older students for self-study.

SURAHS MEMORISATION - from KG to CLASS 3

<u>CLASS</u>	<u>MID - YEAR</u>	<u>END - YEAR</u>
KG	Surah Al-Fatihah (1) Surah Al-Ikhlâs (112)	Surah Al-Kawthar (108) Surah Al-Asr (103)
1	Surah Al-Nas (114) Surah Al-Falaq (113)	Surah Al-Fil (105) Surah Al-Nasr (110)
2	Surah Al-Qadr (97)	Surah Al-Lahab (111) Surah Al-Quraysh (106)
3	Surah Al-Tin (95)	Surah Al-Kafirun (109)

SURAHS TO BE MEMORISED (MID - YEAR)

Surah Al-Fatehah (1) AND Surah Al-Ikhlās (112)

- ❖ The Greatest Surah of the Holy Qur'an
- ❖ You get a lot of Thawab and you are safe
- ❖ It is a cure for every sickness

SURAH AL-FATEHAH (THE OPENING)

SURAH NO: 1

REVEALED IN BOTH
MECCA AND MEDINA

HAS 7 AYAT

بِسْمِ اللَّهِ الرَّحْمَنِ الرَّحِيمِ

الْحَمْدُ لِلَّهِ رَبِّ الْعَالَمِينَ ۝١

الرَّحْمَنِ الرَّحِيمِ ۝٢ مَلِكِ يَوْمِ الدِّينِ ۝٣

إِيَّاكَ نَعْبُدُ وَإِيَّاكَ نَسْتَعِينُ ۝٤

اهْدِنَا الصِّرَاطَ الْمُسْتَقِيمَ ۝٥

صِرَاطَ الَّذِينَ أَنْعَمْتَ عَلَيْهِمْ ۝٦

غَيْرِ الْمَغْضُوبِ عَلَيْهِمْ وَلَا الضَّالِّينَ ۝٧

SURAHS TO BE MEMORISED (MID - YEAR)

Surah Al-Fatehah (1) AND Surah Al-Ikhlās (112)

- ❖ Reciting this Surah 3 times, give you reward of reciting the Whole Qu'ran and your whole family get thawab.
- ❖ All your sins are forgiven
- ❖ Many sicknesses are cured
- ❖ Recommended to recite when travelling

SURAH AL-IKHLAS

(THE UNITY)

SURAH NO: 112

REVEALED IN
MECCA

HAS 4 AYAT

بِسْمِ اللَّهِ الرَّحْمَنِ الرَّحِيمِ

قُلْ هُوَ اللَّهُ أَحَدٌ

اللَّهُ الصَّمَدُ

لَمْ يَلِدْهُ وَلَمْ يُولَدْ

وَلَمْ يَكُنْ لَهُ كُفُوًا أَحَدٌ

SURAHS TO BE MEMORISED (END - YEAR)**Surah Al-Asr (103) AND Surah Al-Kawthar (108)**

- ❖ Reciting this Surah makes us very Patient
- ❖ Gives us Honour and Respect
- ❖ Gives us Protection

SURAH AL-ASR**(TIME)****SURAH NO: 103****REVEALED IN
MECCA****HAS 3 AYAT**

بِسْمِ اللَّهِ الرَّحْمَنِ الرَّحِيمِ

وَالْعَصْرِ ۝

إِنَّ الْإِنْسَانَ لِفِي خُسْرٍ ۝

إِلَّا الَّذِينَ آمَنُوا وَعَمِلُوا الصَّالِحَاتِ

وَتَوَاصَوْا بِالْحَقِّ ۝

وَتَوَاصَوْا بِالصَّبْرِ ۝

SURAHS TO BE MEMORISED (END - YEAR)

Surah Al-Asr (103) AND Surah Al-Kawthar (108)

- ❖ Whoever recites this Surah in his daily prayers after Surah Al-Fatehah, he will drink from the Fountain of Kawthar.

SURAH AL-KAWTHAR (THE HEAVENLY FOUNTAIN)

SURAH NO: 108

REVEALED IN
MECCA

HAS 3 AYAT

بِسْمِ اللَّهِ الرَّحْمَنِ الرَّحِيمِ

إِنَّا أَعْطَيْنَاكَ الْكَوْثَرَ ۝

فَصَلِّ لِرَبِّكَ وَانْحَرْ ۝

إِنَّ شَانِئَكَ هُوَ الْأَبْتَرُ ۝

K A L E M A

بِسْمِ اللَّهِ الرَّحْمَنِ الرَّحِيمِ

لَا إِلَهَ إِلَّا اللَّهُ مُحَمَّدٌ رَّسُولُ اللَّهِ عَلِيُّ وَليُّ اللَّهِ

وَصِيُّ رَّسُولِ اللَّهِ وَخَلِيفَتُهُ بِلاَ فَصْلِ

TRANSLITERATION

LA ILAHA ILLALLAH

MUHAMMADUR RASULALLAH

ALI YUN WALI YULLAH

WASI YUN RASULALLAH

WA KHALIIFATAHU BILAA FASL

TRANSLATION

There is No god but Allah

Muhammad is his Messenger

Ali is his Chosen One

He is the Helper of the Prophet

And He is the First Khalifa of the Prophet

SHORT DUA - DUA E FARAJ

اللَّهُمَّ كُنْ لِوَلِيِّكَ الْحُجَّةِ بْنِ الْحَسَنِ صَلَواتِكَ عَلَيْهِ
 وَعَلَى آبائِهِ فِي هَذِهِ السَّاعَةِ وَفِي كُلِّ سَاعَةٍ وَلِيًّا
 وَحَافِظًا وَقَائِدًا وَنَاصِرًا وَدَلِيلًا وَعَيْنًا حَتَّى تُسَكِّنَهُ
 أَرْضَكَ طَوْعًا تَتَّبِعُهُ فِيهَا طَوِيلًا

TRANSLITERATION:

Allaahumma kulle-Waliyyekal Hujjatibnil Hasan, Salawaatuka A'layhe Wa A'laa Aabaa-Ehi, Fee Haazehis Saa-A'te, Wa Fee Kulle Saa-A'tin, Waliyyawn Wa Haafezan Wa Qaa-Edan Wa Naaseran, Wa Daleelan Wa A'ynan, Hattaa Tuskenahu Arzaka Taw-A'n, Wa Tomatte-A'hu Feehaa Taweelaa.

TRANSLATION:

O Allah! Protect your Vicegerent Hujjat (The Proof), son of Hassan and send Salutations upon him, and his ancestors, now as well as at all times,

(as our) Imam, Guardian, Supporter, and Guide until such time when you Bestow upon him the honour of heading the (Divine) Government.

And let the people be delighted in his reign, by bestowing Success, and by extending his reign.

☆ ☆ ☆ — ☆ ☆ ☆

SHORT DUAS

DUA FOR KNOWLEDGE

رَبِّ زِدْنِي عِلْمًا

"Rabbi Zid-Nee 'Il-Maan"

My Lord, increase me in Knowledge

Recite this Dua
every time you sit
to learn something.

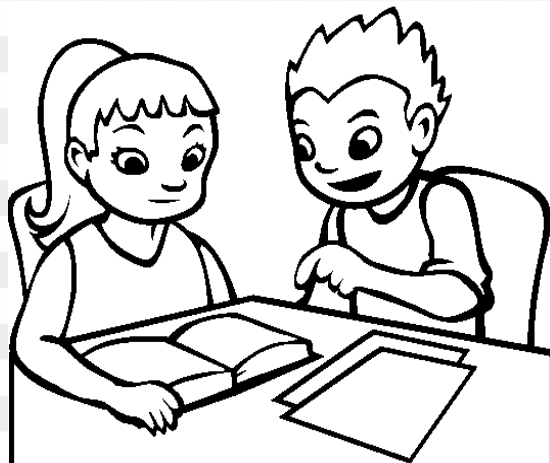

This Dua will help
you to understand
better.



SHORT D U A S

DUA FOR BEING KIND

جَزَاكَ اللهُ خَيْرًا

"Jazaakallahu Khairaa"

May Allah (SWT) return your kindness



We say this dua
to someone who
has been kind to us.

ISLAMIC PHRASES AND WHAT THEY MEAN

1.) When we begin to do something, we say:

"Bismillahir Rahmaanir Rahim"

بِسْمِ اللّٰهِ الرَّحْمٰنِ الرَّحِیْمِ

Meaning:

"In the name of Allah, the Most Kind, the Most Merciful"

We say "Bismillahir Rahmaanir Rahim":-

Before we eat



Before we work

Before we sleep



ISLAMIC PHRASES AND WHAT THEY MEAN

2.) When we meet another Muslim, we say:

**"As Salaamu Alaikum
Wa Rahmatullah Wa
Barakatuhu"**

Meaning:

"May the Mercy, Peace and Blessings of Allah be upon You"

And they will Reply:

"Wa Alaikum Salaam Wa Rahmatullah Wa Barakatuhu"

Meaning: "And may the Peace, Mercy and Blessings of Allah be upon You"



ISLAMIC PHRASES AND WHAT THEY MEAN



3.) To thank Allah, we say:

"Shukraan Lillah"

Meaning:

"Thank you Allah"

4.) To thank someone, we say: "Jazakallahu Khair"

Meaning: "May Allah reward you with good"

5.) When we sneeze, we say:

"Alhamdulillah" Meaning:

"All praise is due to Allah"

and any Muslim present must reply:

"Yar Hamuk Allah"

Meaning: "May Allah have Mercy on you"



6.) To appreciate something, we say:

"Masha Allah" Meaning: "Whatever Allah Wills"

7.) When we reply to a Thank you (Shukran), we say

AFWAN - which means "you are Welcome"

8.) When reciting SALAWAAT, we say:

“ALLAHUMMA SALLI ALAA
 MUHAMMADIN WA AALE
 MUHAMMAD”



“O Allah, send Your Blessing on The Holy Prophet Muhammad (SAW) and his family”

When we recite Salawaat (our gift to the Holy Prophet):



- ❖ Allah and the Angels Bless us
- ❖ Our Duas are accepted
- ❖ The Prophet is very happy
- ❖ We will have good in this world and the next world
- ❖ We become free from being poor
- ❖ Our memory becomes powerful



HOW THE HOLY QUR'AN CAME TO US

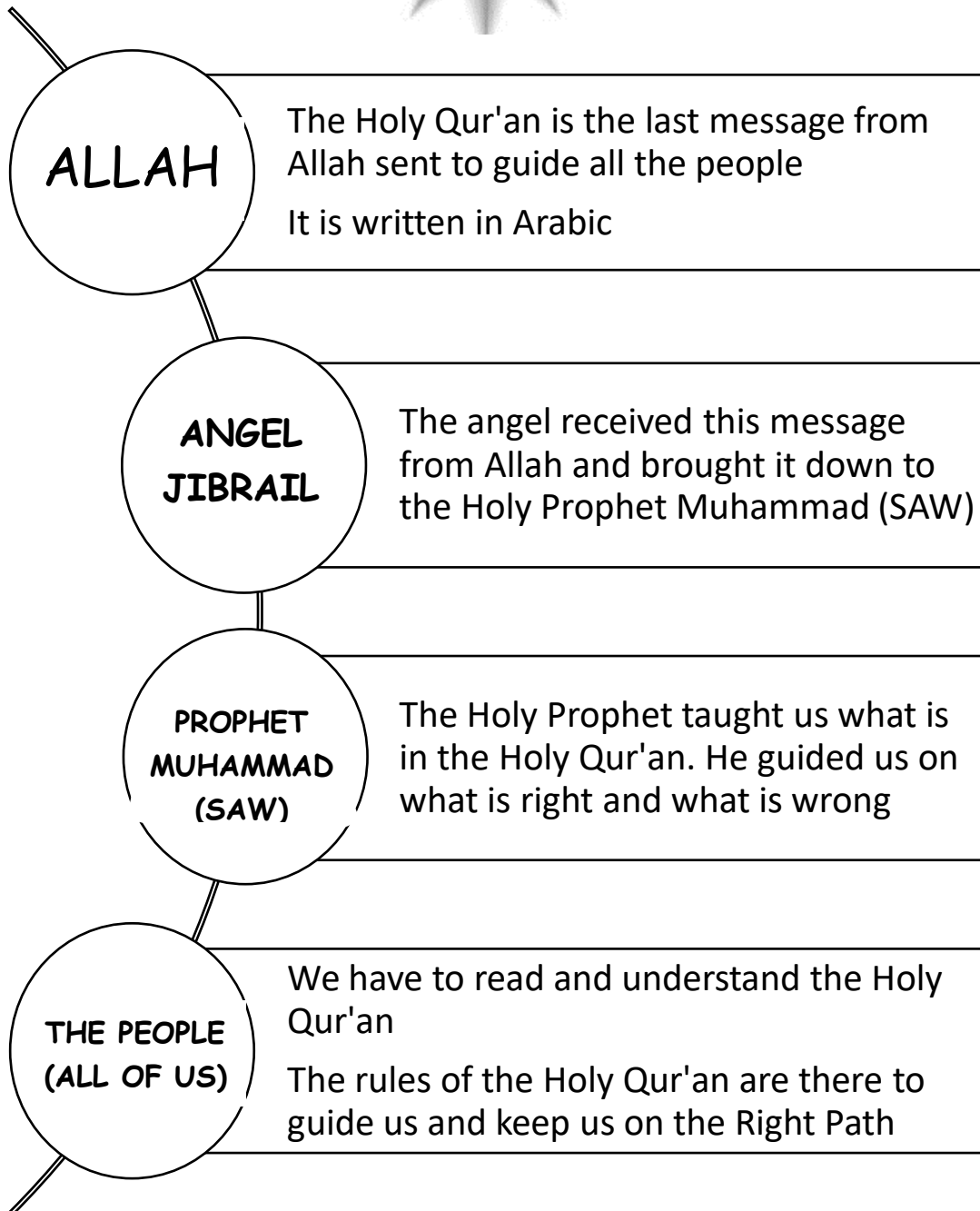
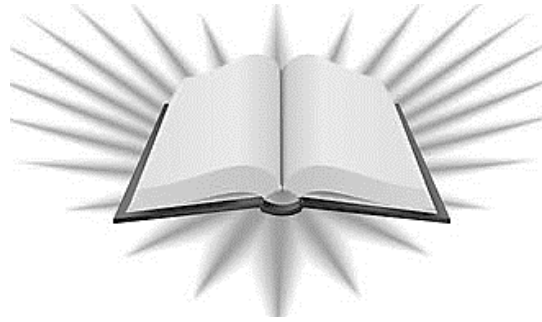

HOW TO RESPECT THE HOLY QUR'AN

We Love the Holy Qur'an
and take good care of it.

We should brush our
teeth before reciting
the Holy Qur'an

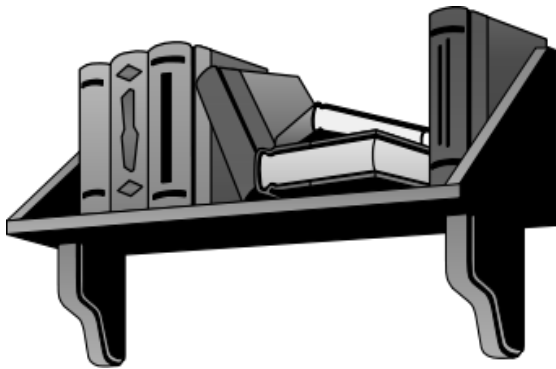
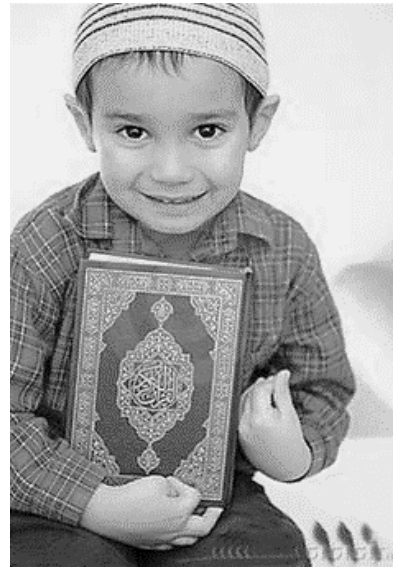

Always keep the
Qur'an on the shelf
and never keep it
on the floor.

We sit respectfully
and cover our head
when we recite
the Holy Qur'an.



MOTOR CONTROL

Exercises 1 - 10 in the following pages have been designed to assist the child in his/her handwriting skills.

Connecting the lines or the dots, using the Eye-Hand co-ordination will assist in establishing their motor control and movement, in making the formation of the letters.

Make sure of the following:

- 1.) The correct sitting Posture of the body is important. The child should be comfortable
- 2.) The grip of the Pencil is also important. In the initial stages, parents/teachers should assist the child in the movement over the lines/dots. This will help in the co-ordination of the eye-hand-pencil connection.

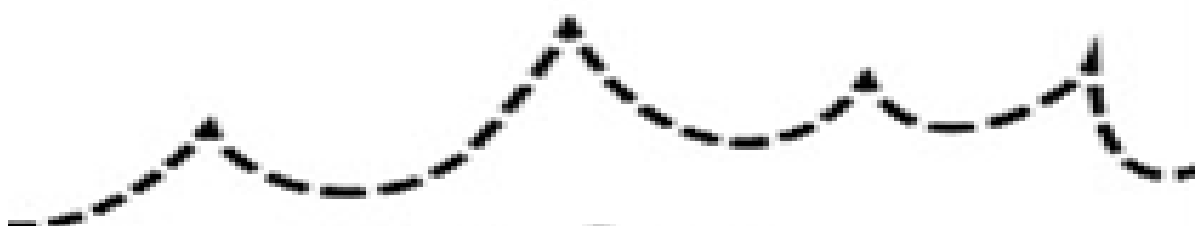

EXERCISE 1: MOTOR CONTROL ACTIVITY

Join the dots and colour the picture

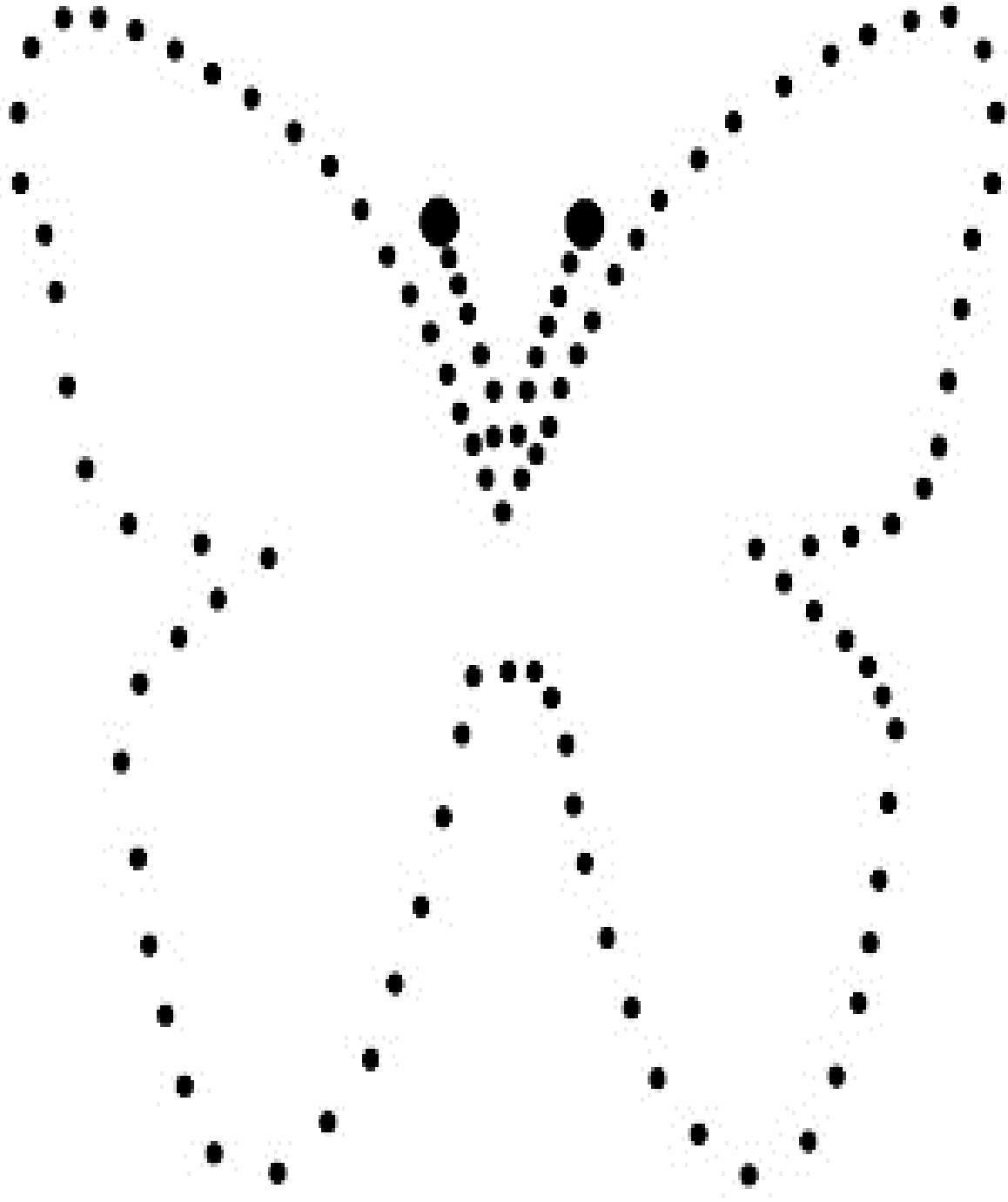

EXERCISE 2: MOTOR CONTROL ACTIVITY

Join the dots and colour the pictures

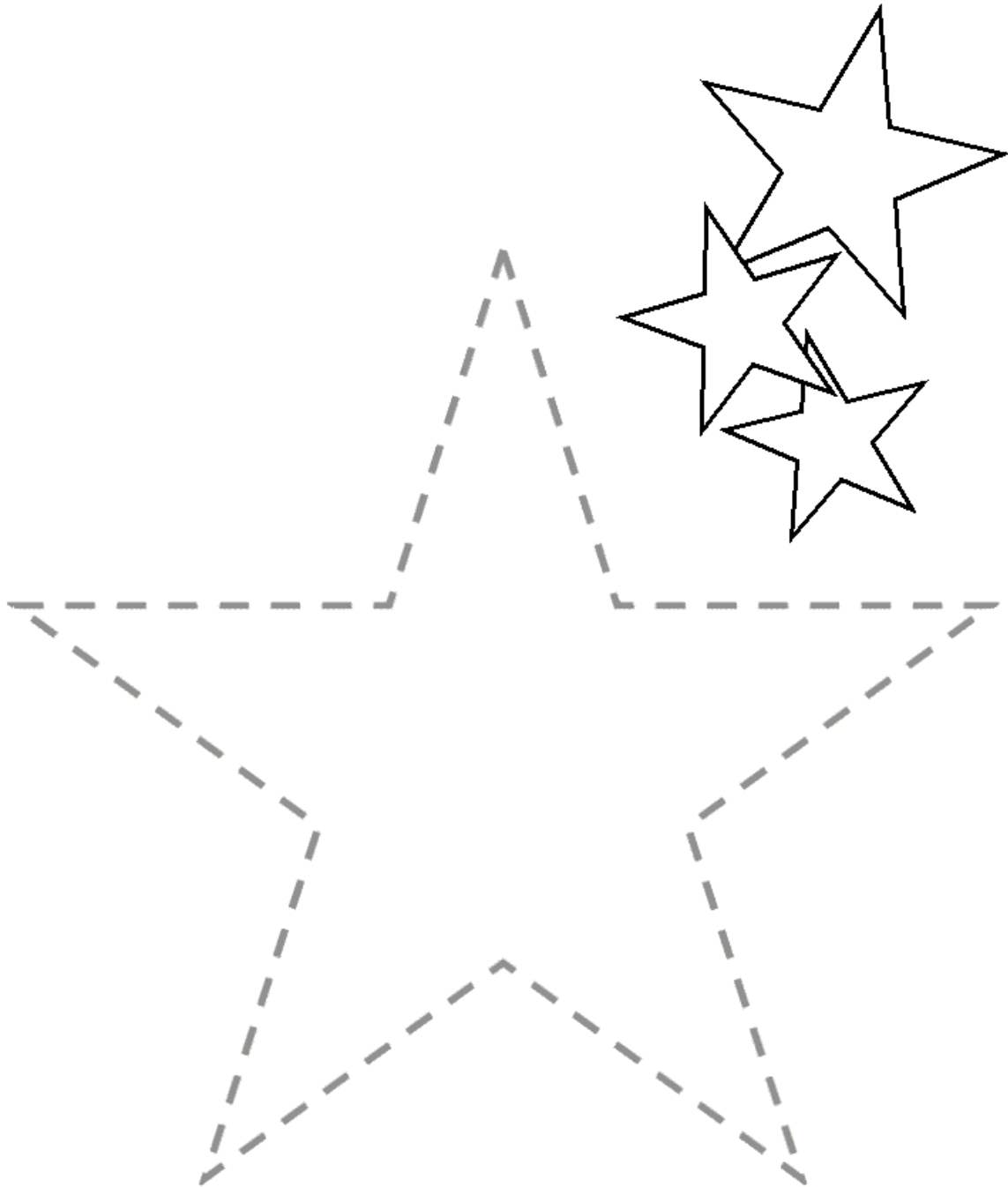

EXERCISE 3: MOTOR CONTROL ACTIVITY

Join the dots and colour the picture

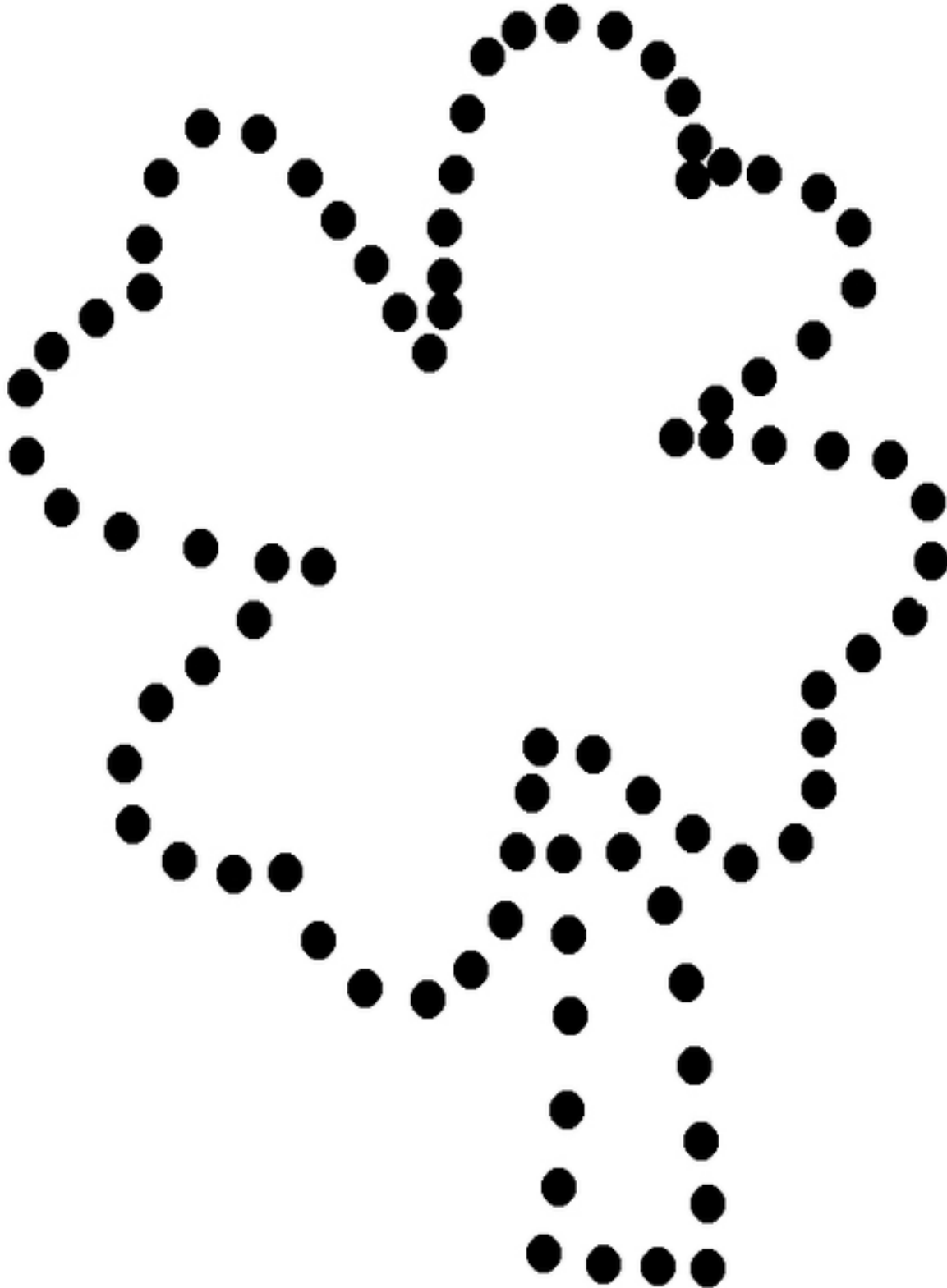

EXERCISE 4: MOTOR CONTROL ACTIVITY

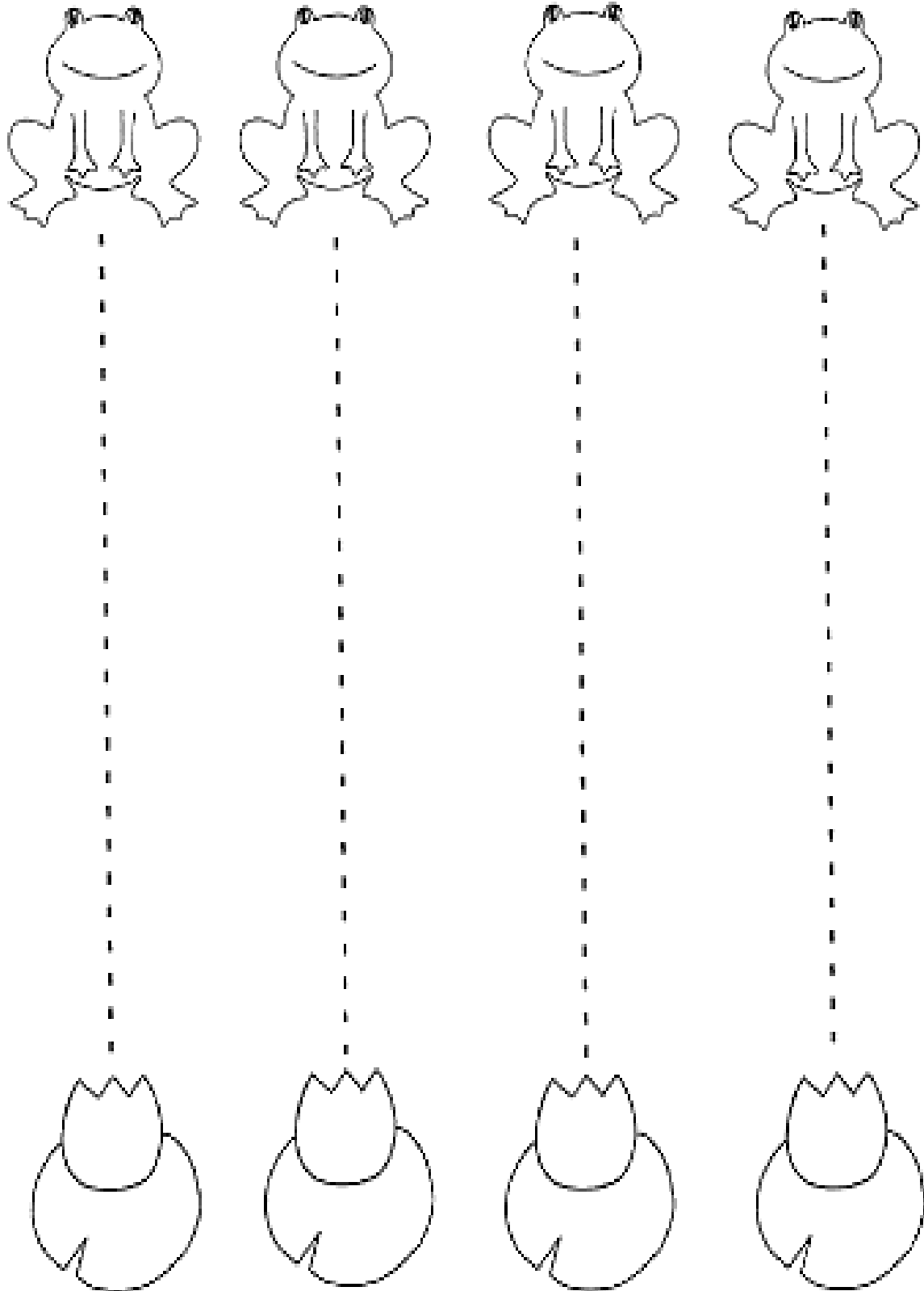

EXERCISE 5: MOTOR CONTROL ACTIVITY

Join the dots and colour the picture

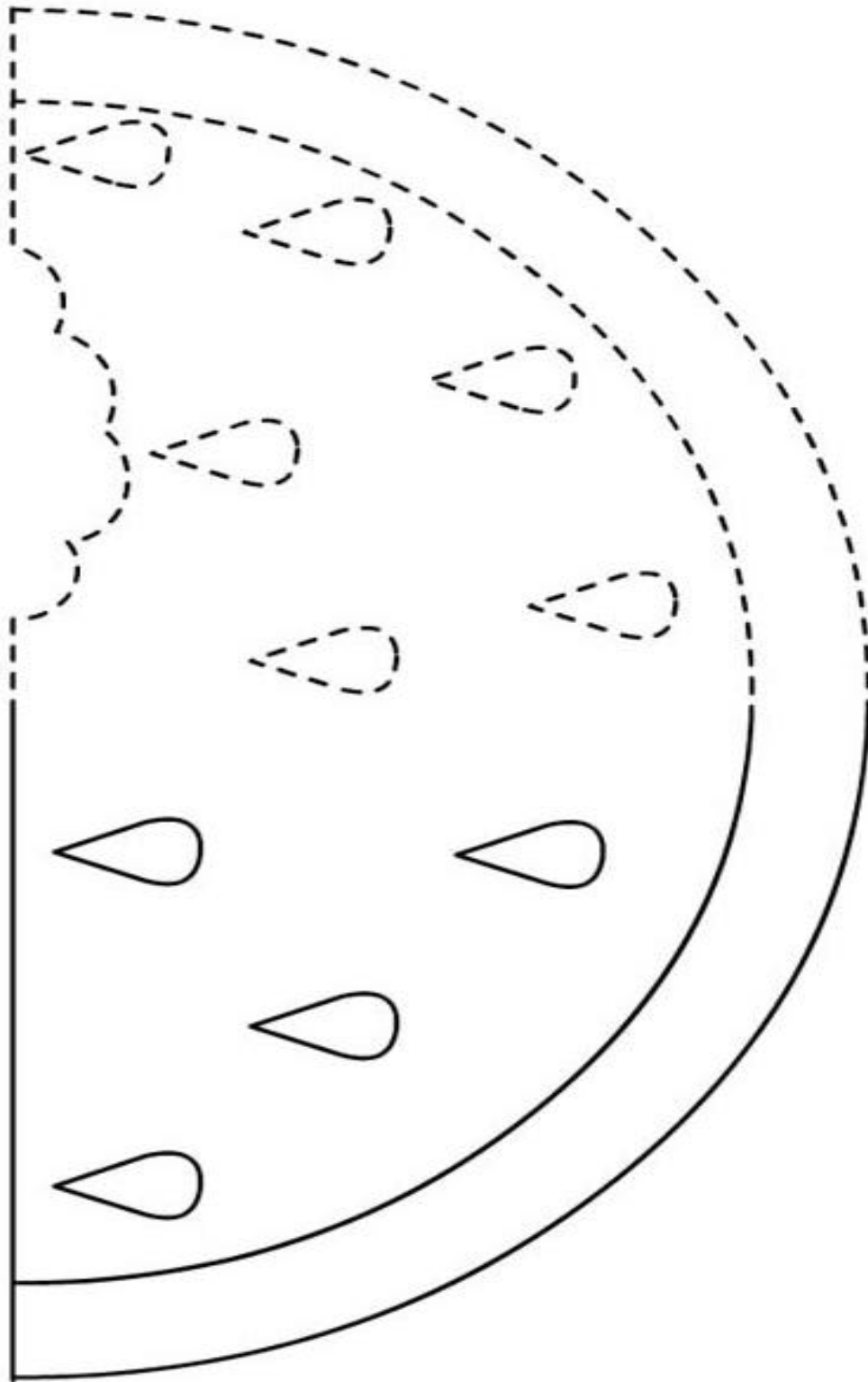

EXERCISE 6: MOTOR CONTROL ACTIVITY

Join the dots and colour the picture

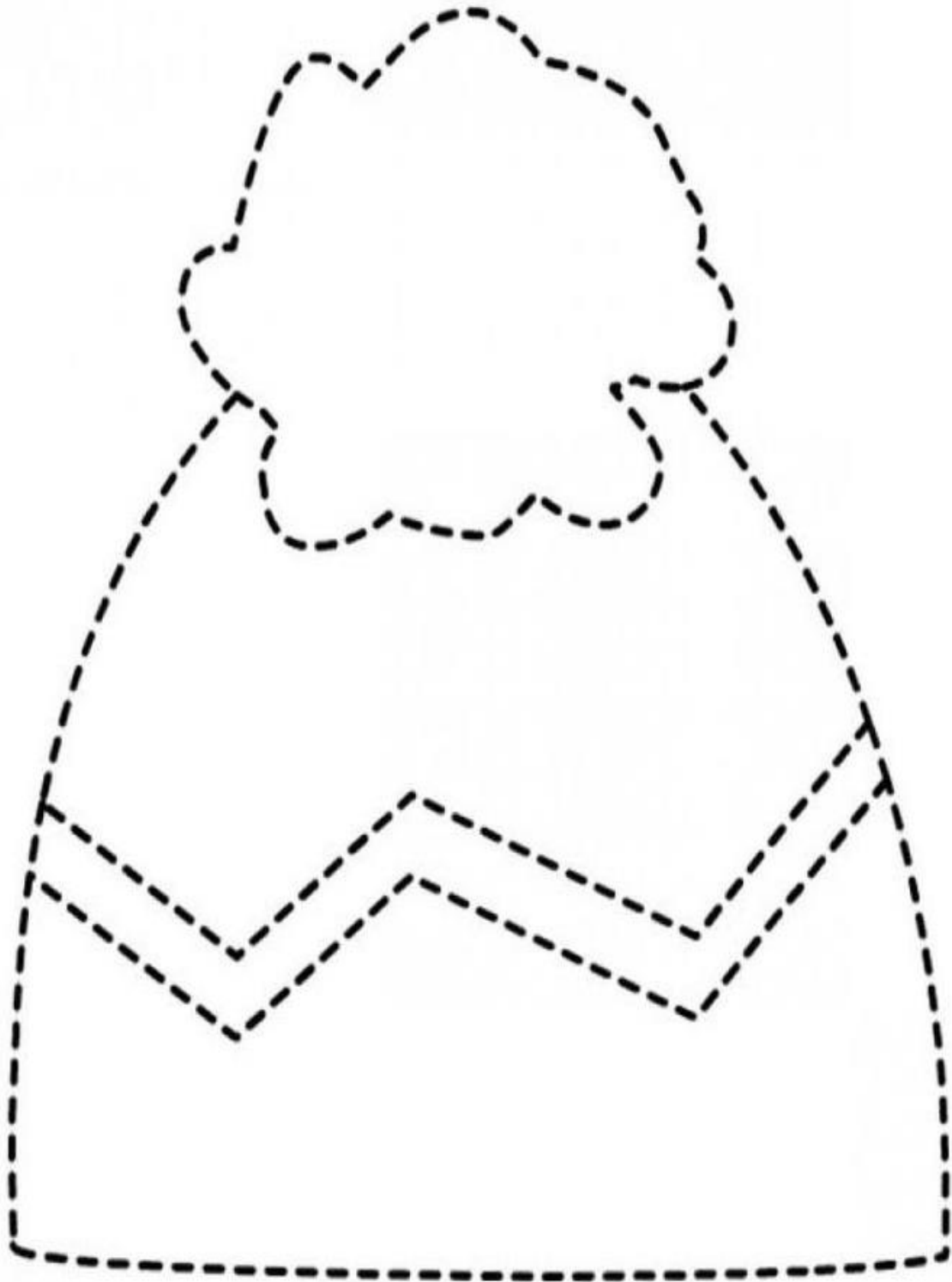

EXERCISE 7: MOTOR CONTROL ACTIVITY

Join the dots and colour the picture

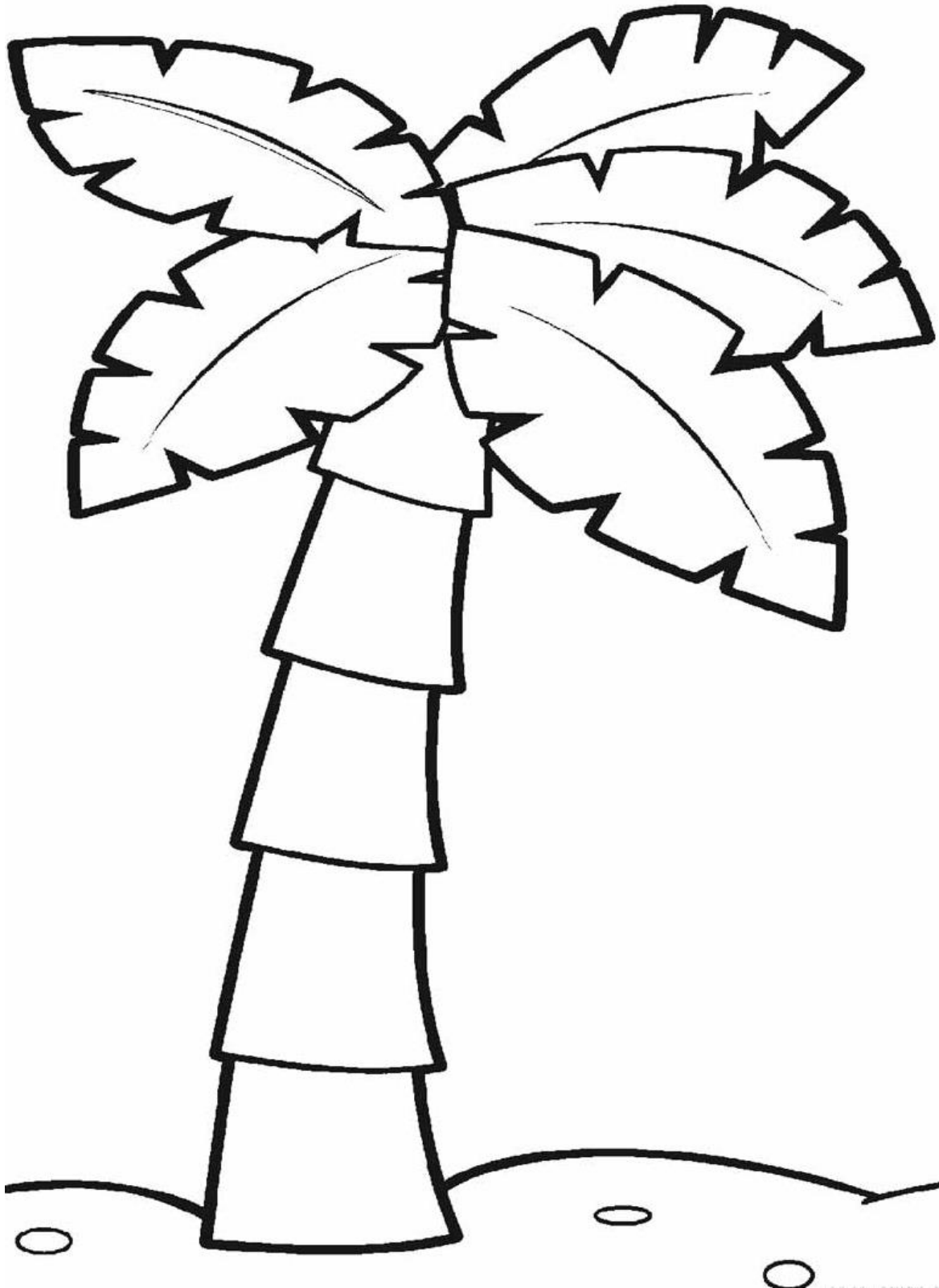

EXERCISE 8: : MOTOR CONTROL ACTIVITY

Join the dots and colour the picture



EXERCISE 9: MOTOR CONTROL ACTIVITY

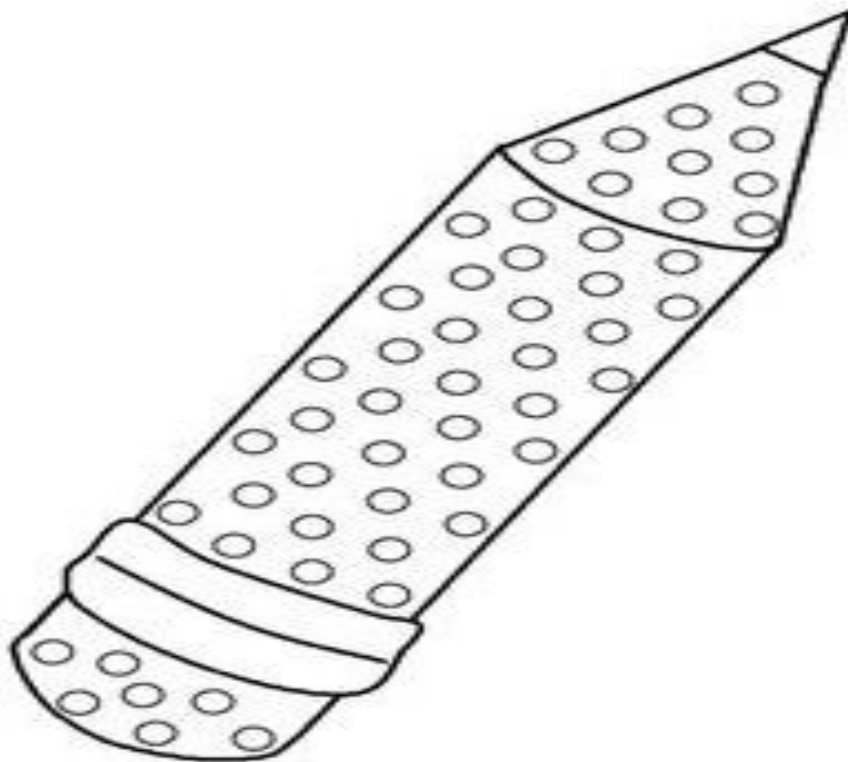
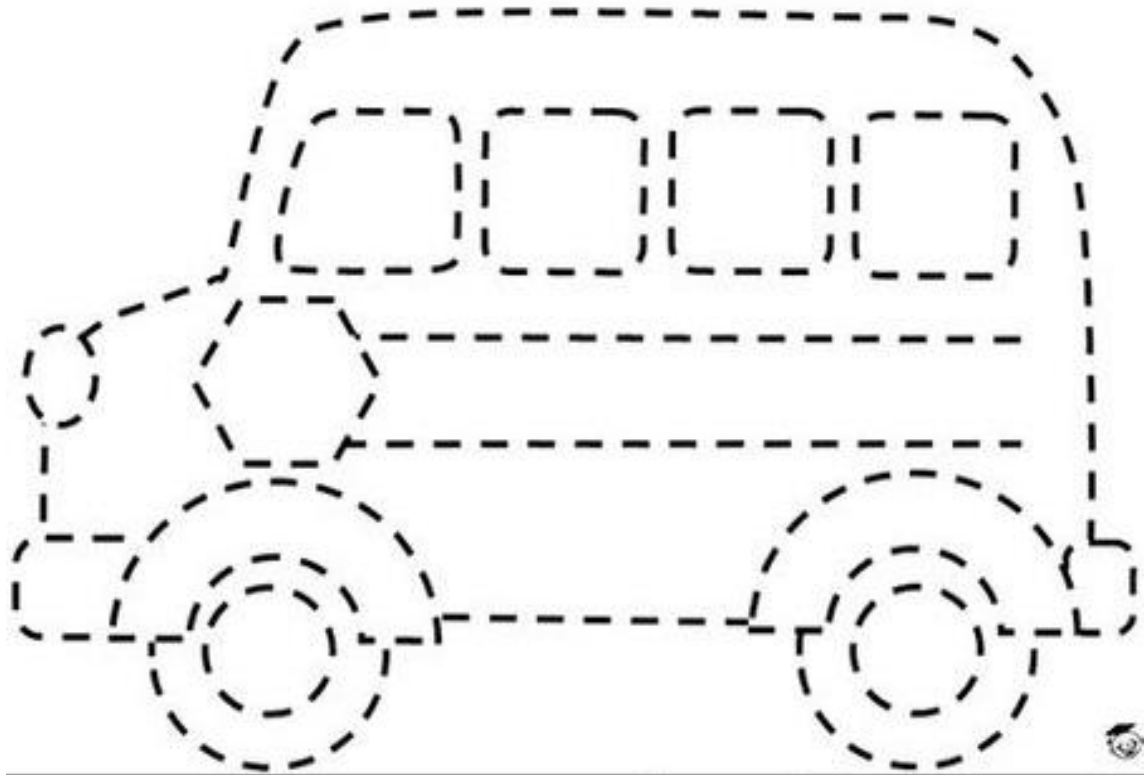

EXERCISE 10: MOTOR CONTROL ACTIVITY

Join the dots and colour the picture

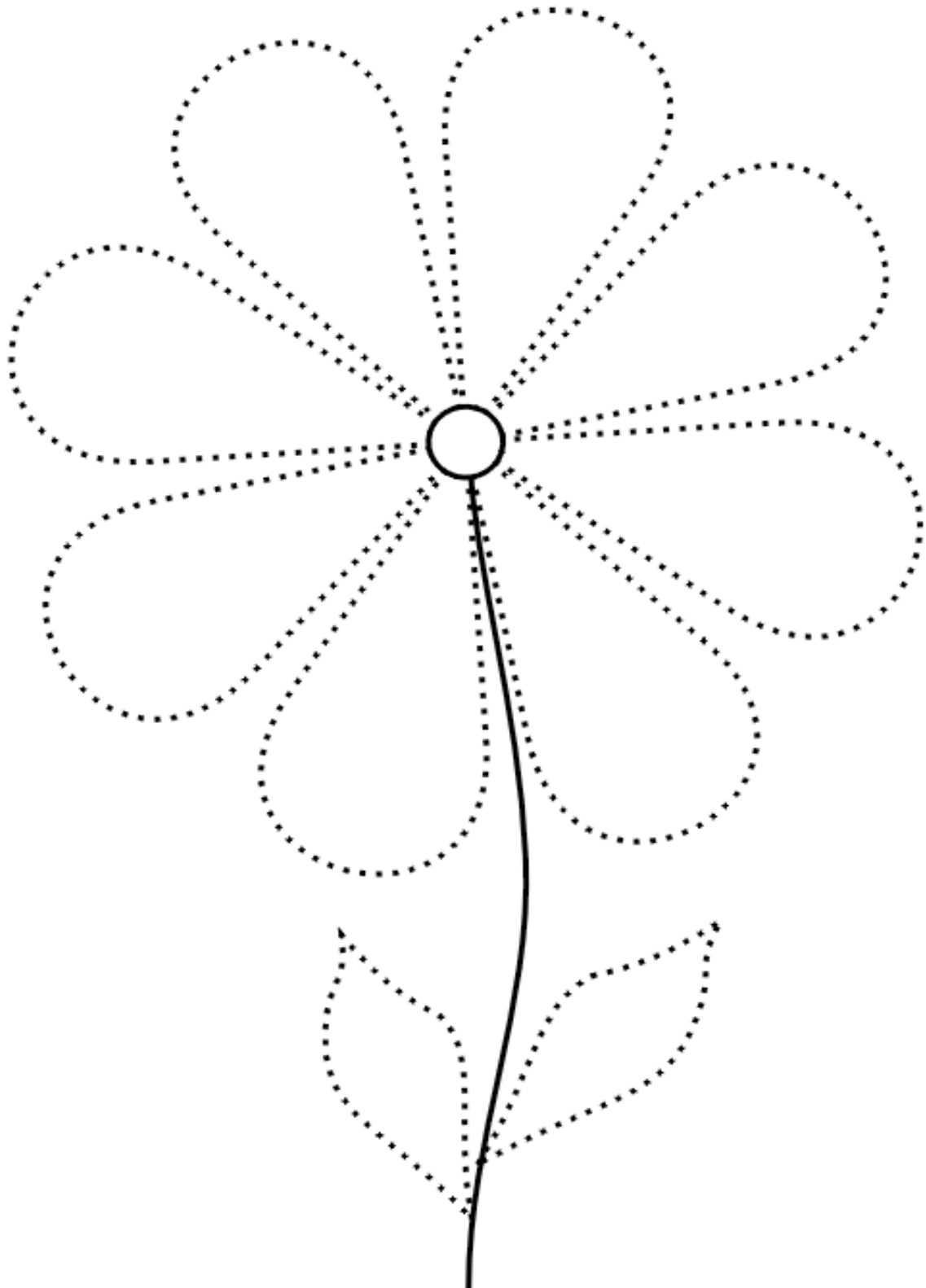

LETTER RECOGNITION PRACTICE

READING & WRITING OF LETTERS

Below are numerous exercises which will aid the student to recognize the letters in a gradual manner. The introduction highlights only a few letters at a time.

Later on we have exercises where all the letters are mixed and the child should be able to identify these letters and say them with the right Makharij, with good speed and NO assistance by the parent/teacher.

When this stage is fully accomplished, feel free to go ahead with other chapters.

TEACHING METHOD:







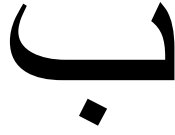

- 1.) Write and pronounce the letter. The student should repeat the letter after you.

- 2.) Allow the child to read and identify the letter from the table.

- 3.) When the child is comfortable with the identification table and is aware of each letter and how it is to be pronounced, then proceed to the writing and colouring exercises.

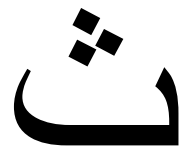





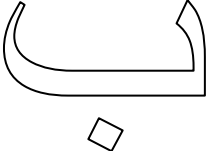

INTRODUCTION TO FIRST 10 ALPHABETS

ALIF TO RE - LETTER NAMES & SOUNDS

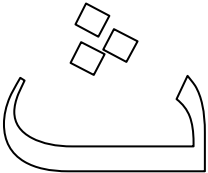
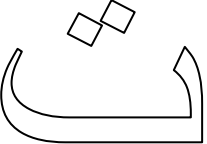
		
Te (ta)	Be (ba)	Alif (a - Light)
		
Hai (ha - Light)	Jim (ja)	The (th)
		
Dhal (dh)	Dal (da)	Khai (kh)
		
	Re (ra)	

EXERCISE 11: LETTER RECOGNITION

Write over the letter

EXERCISE 12: LETTER RECOGNITION

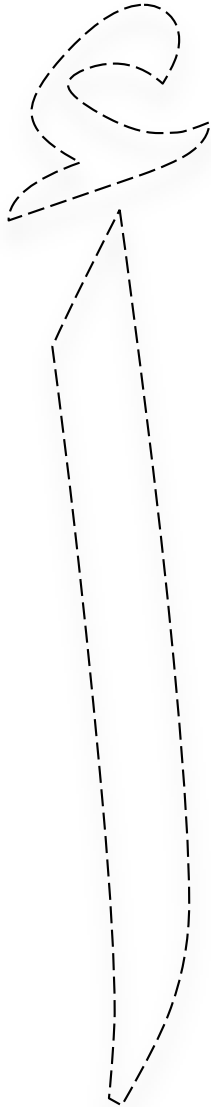

ALIF (a)

EXERCISE 13: LETTER RECOGNITION

أَزْنَبُ

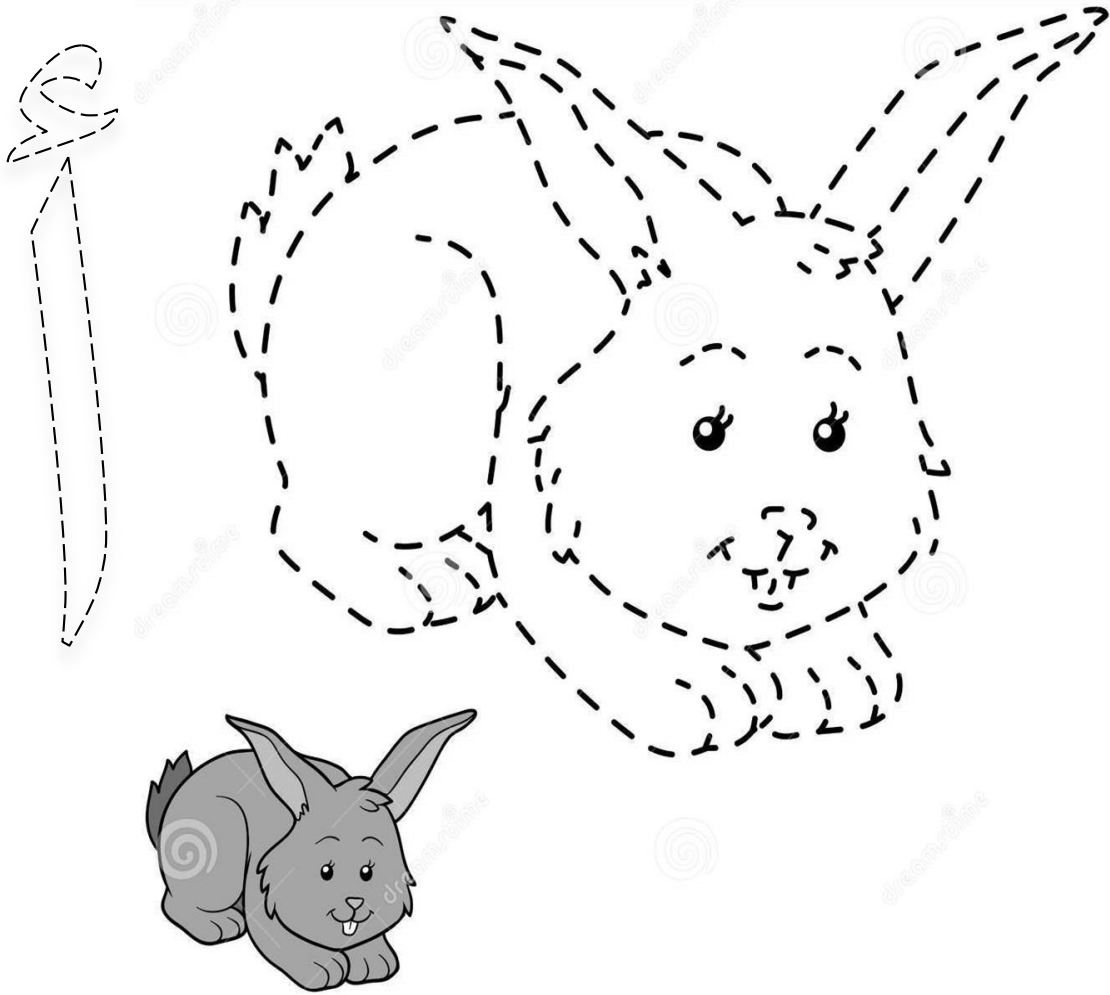

ALIF (a)

EXERCISE 14: LETTER RECOGNITION

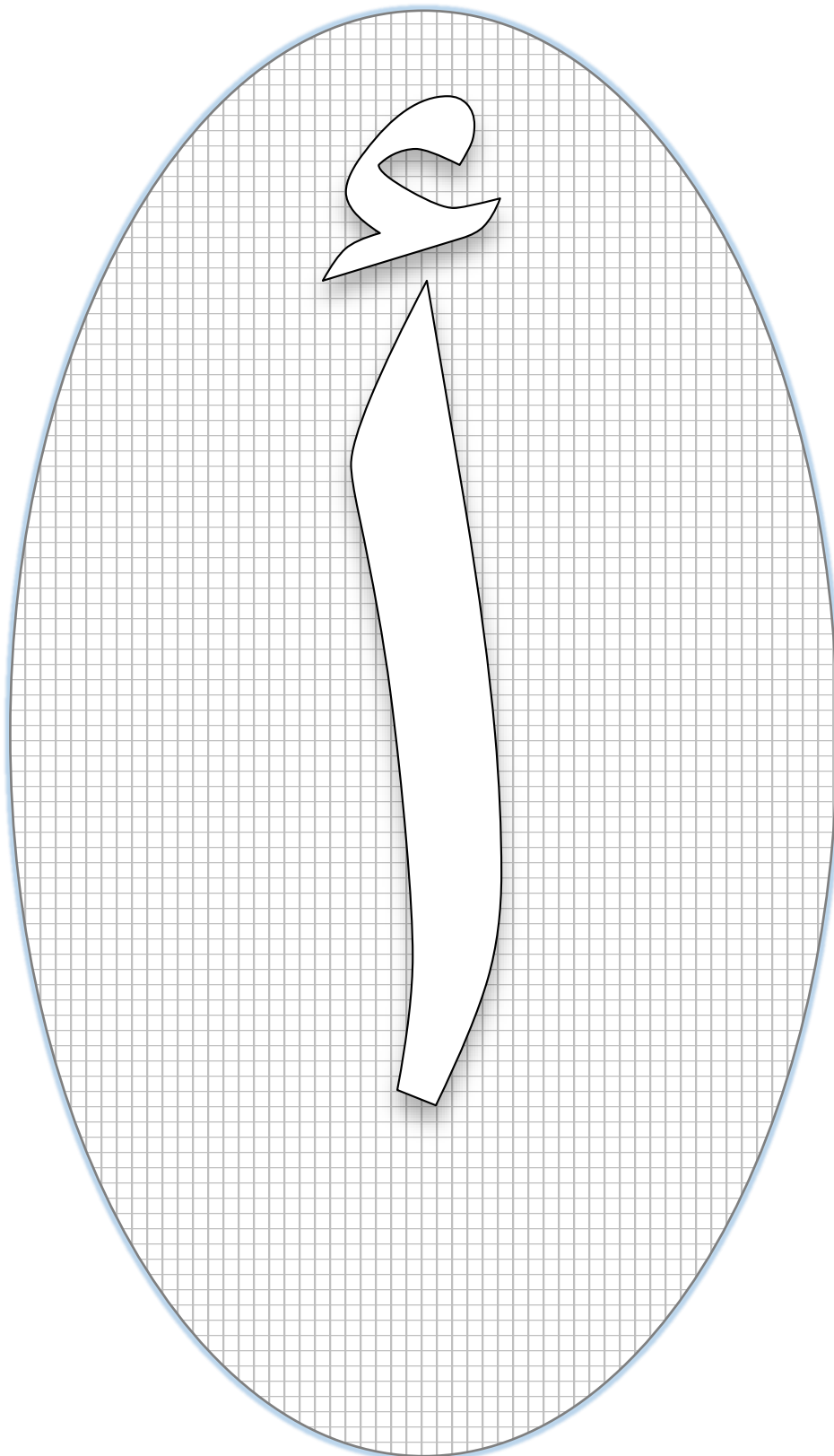

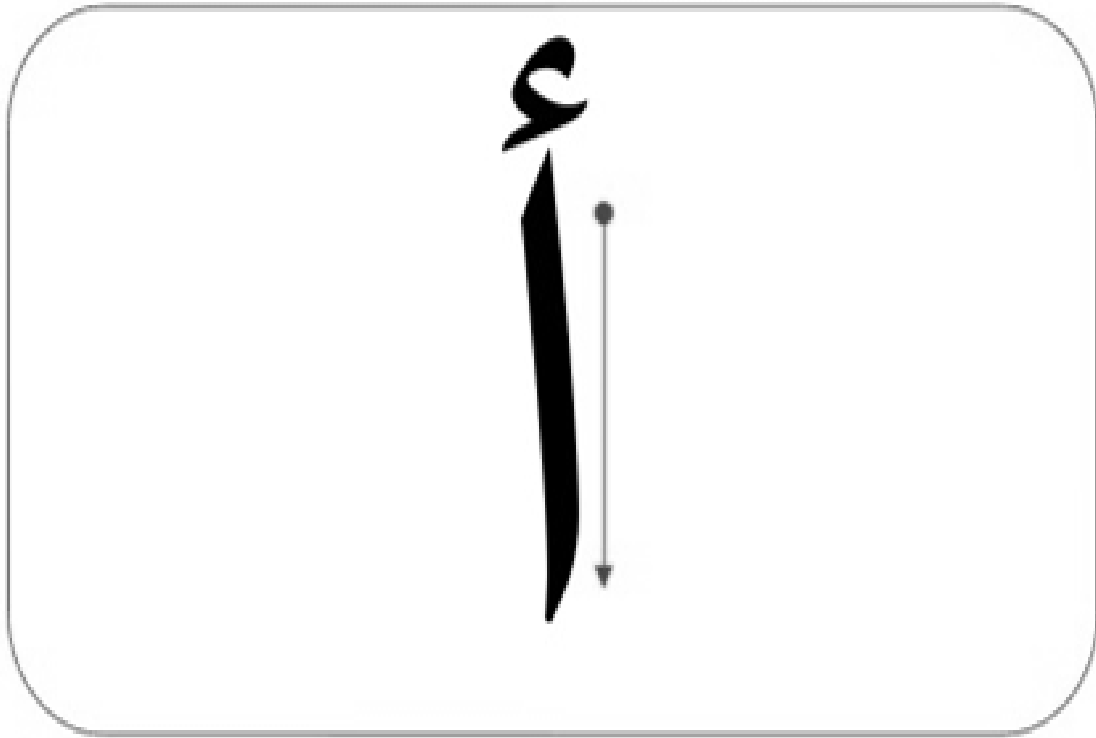

EXERCISE 15: LETTER RECOGNITION

Join the dots and write the letter

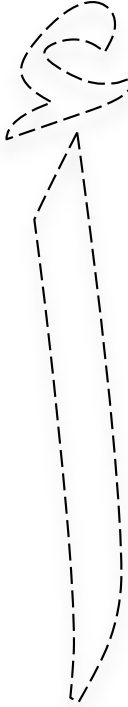

EXERCISE 16: LETTER RECOGNITION

Choose the matching letter below

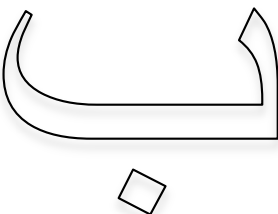
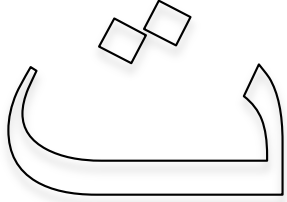
EXERCISE 17: LETTER RECOGNITION

BE

(ba)

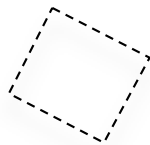
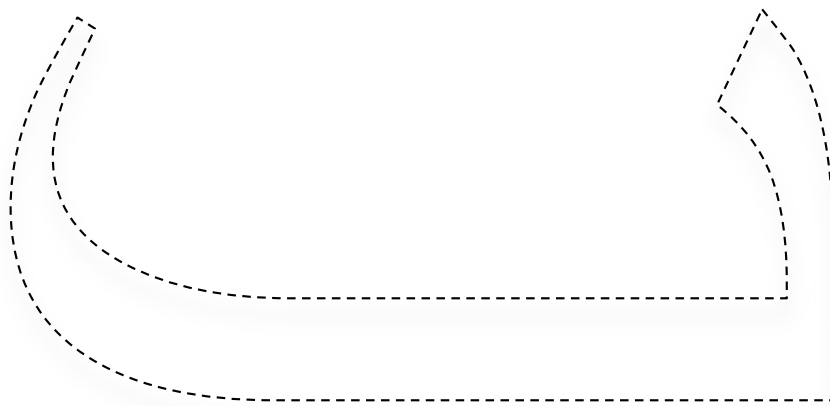

EXERCISE 18: LETTER RECOGNITION

Be

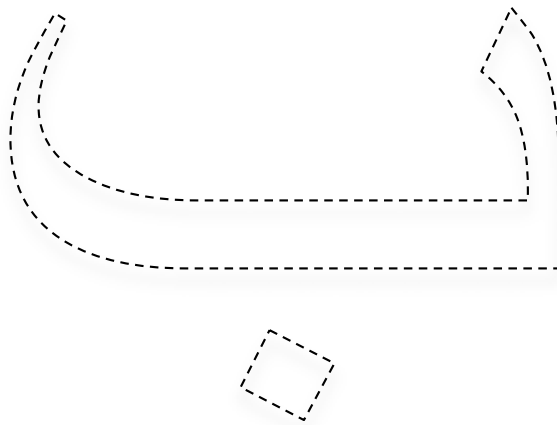

(ba)



EXERCISE 19: LETTER RECOGNITION

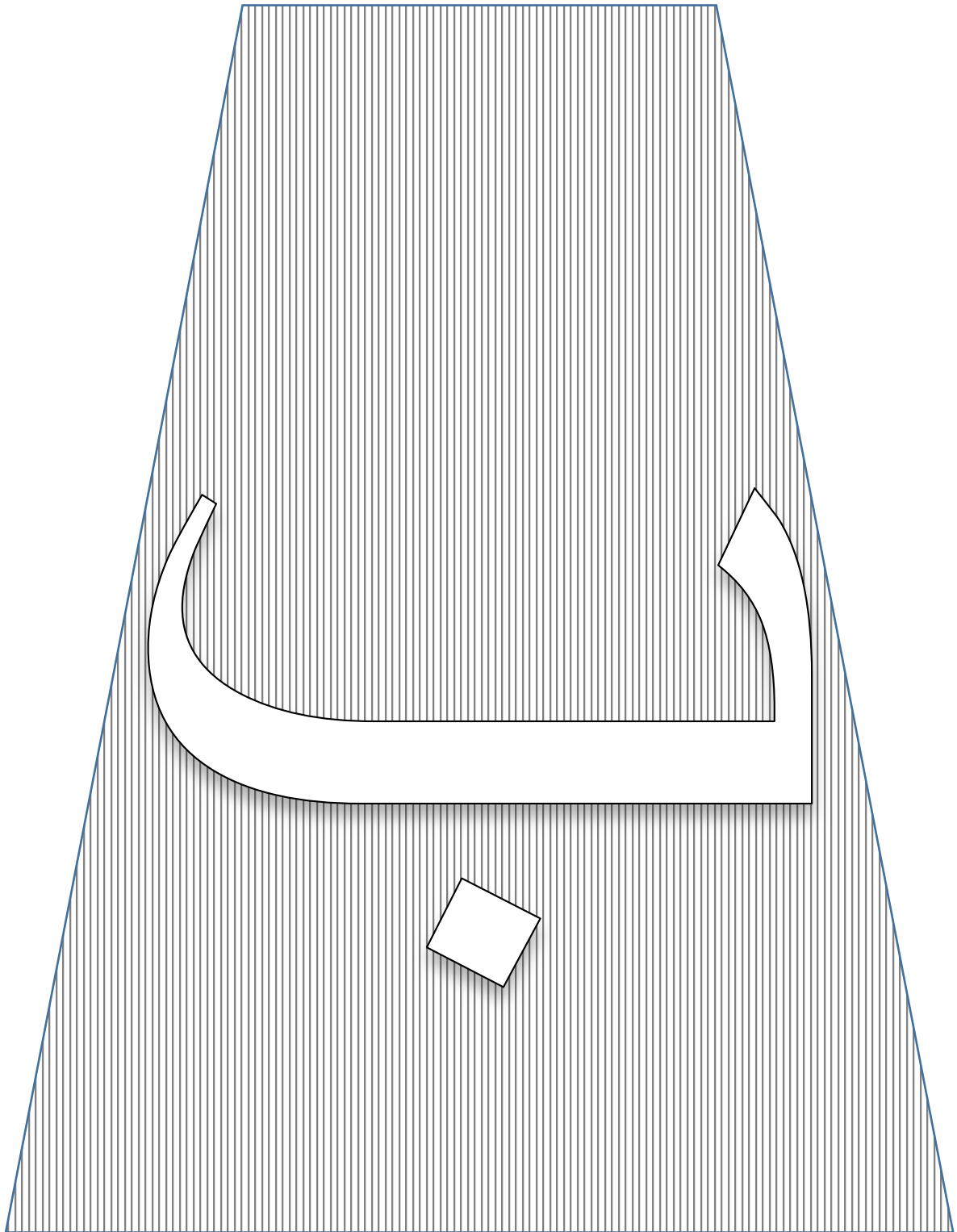

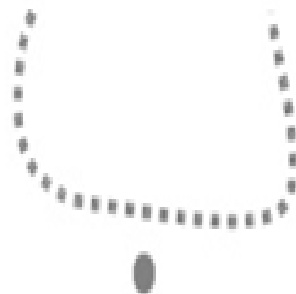
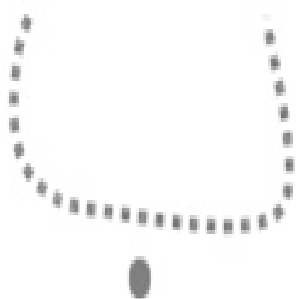
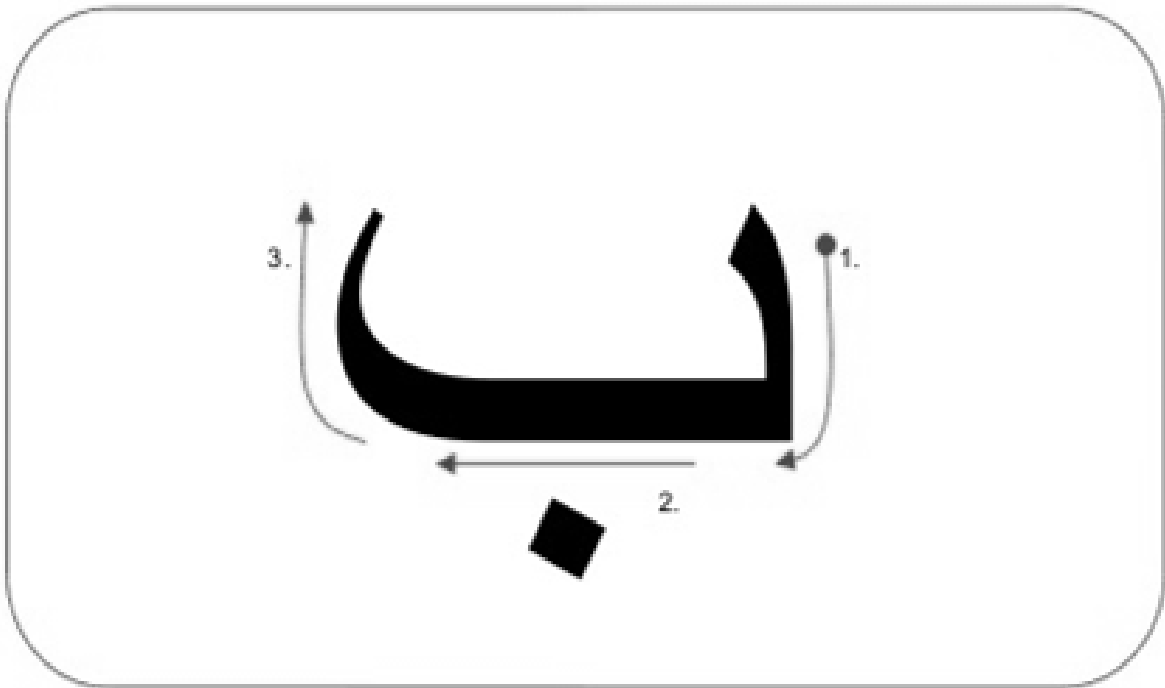

EXERCISE 20: LETTER RECOGNITION

Join the dots and write the letter

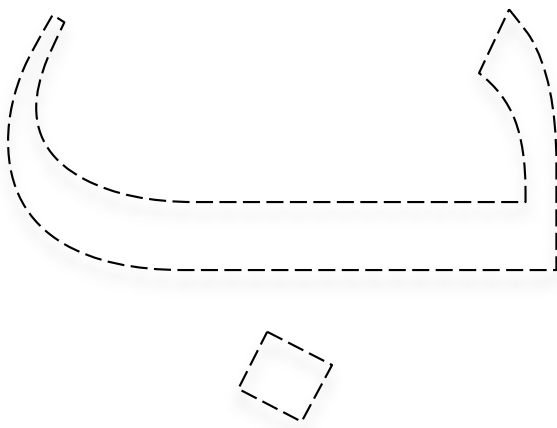
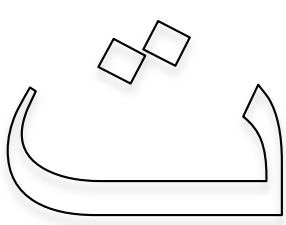

EXERCISE 21: LETTER RECOGNITION

Choose the matching letter below

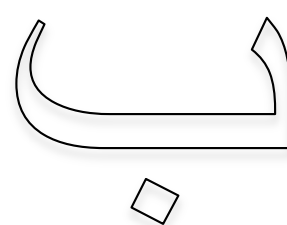
EXERCISE 22: LETTER RECOGNITION

TE

(ta)

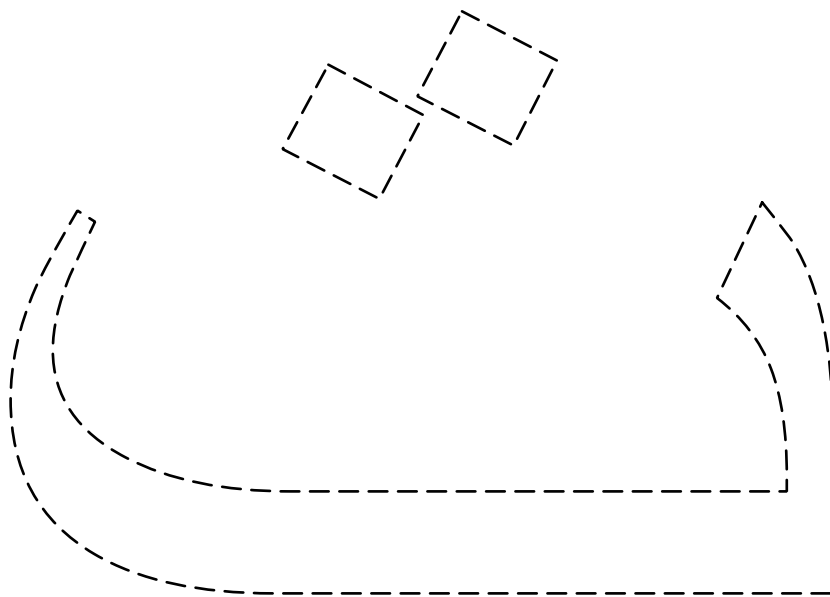

EXERCISE 23: LETTER RECOGNITION

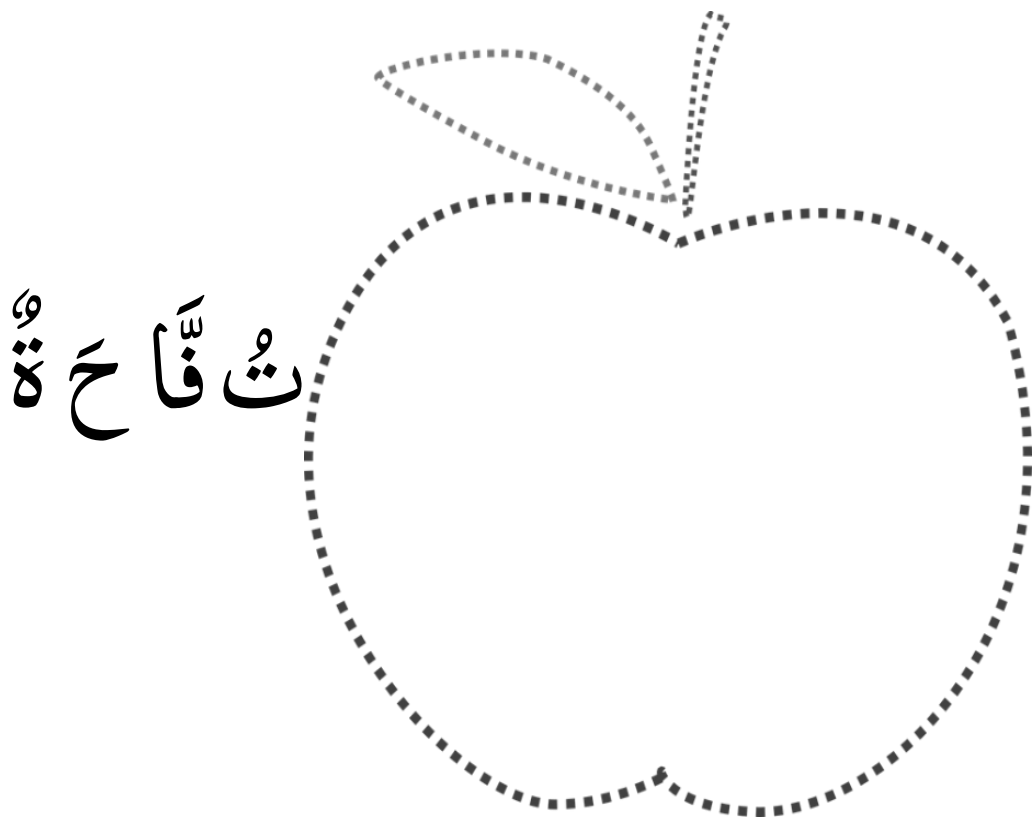
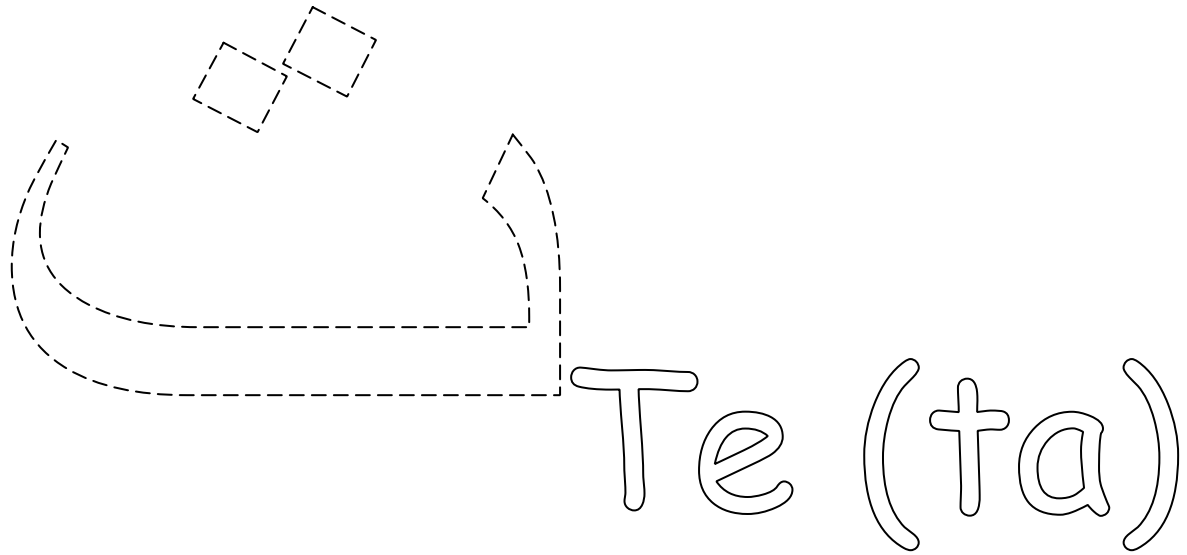

EXERCISE 24: LETTER RECOGNITION

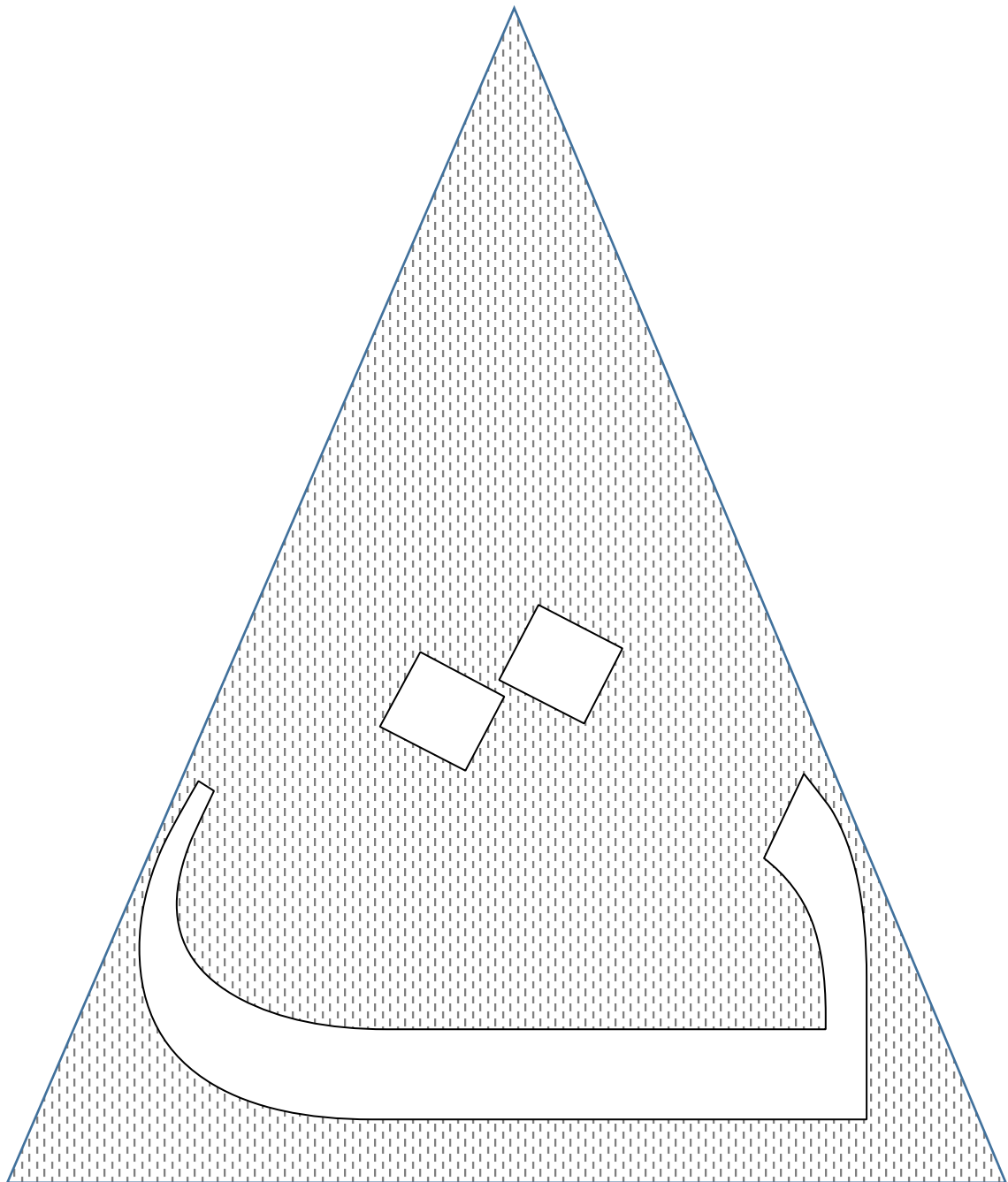

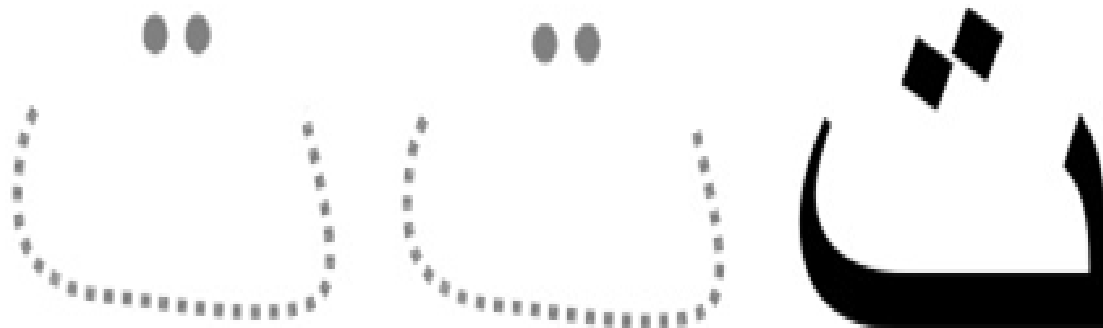
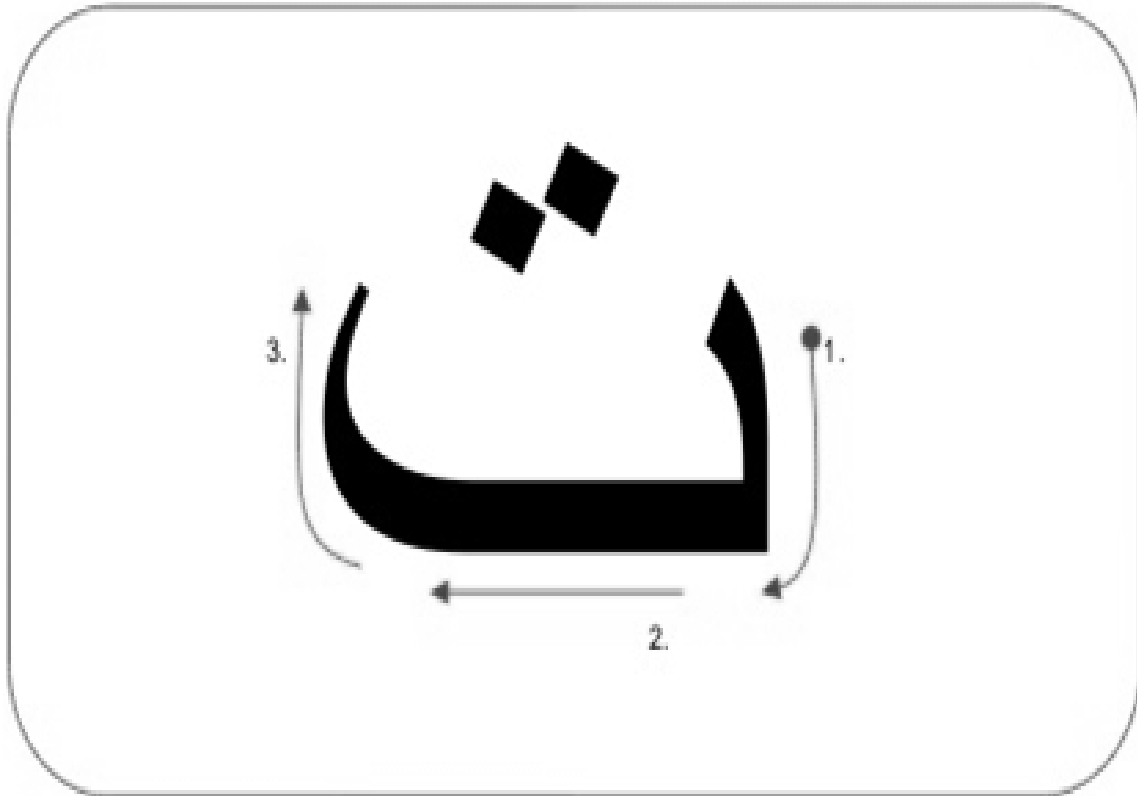

EXERCISE 25: LETTER RECOGNITION

Join the dots and write the letter

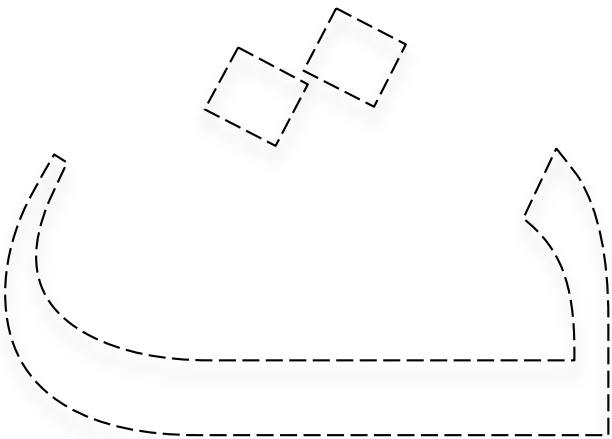
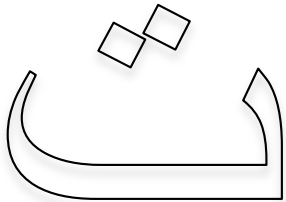
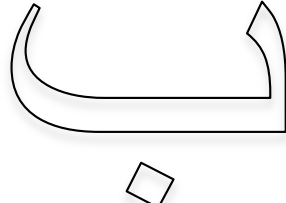

EXERCISE 26: LETTER RECOGNITION

Choose the matching letter below

		
		

EXERCISE 27: LETTER RECOGNITION

The (th)

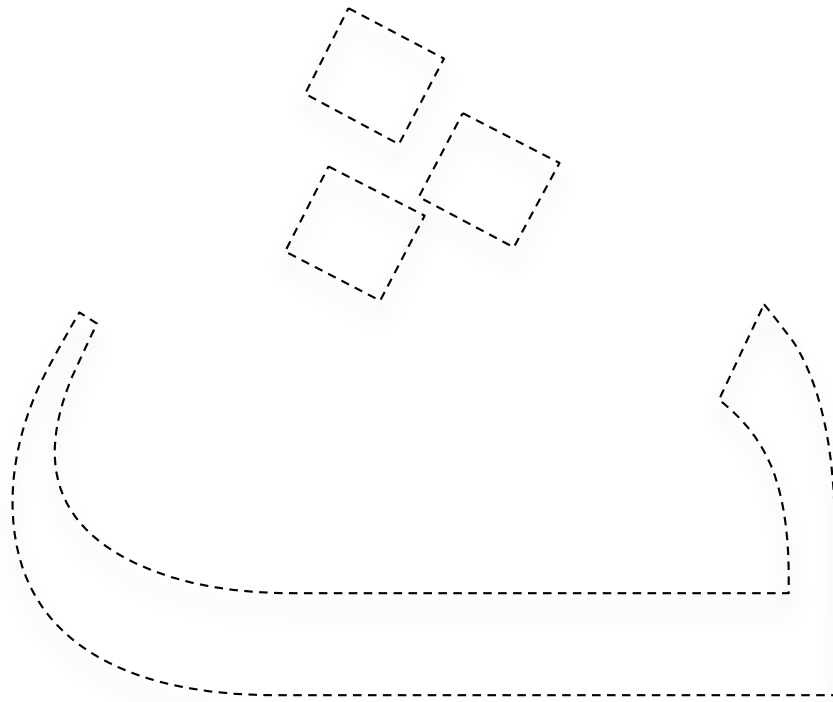

EXERCISE 28: LETTER RECOGNITION

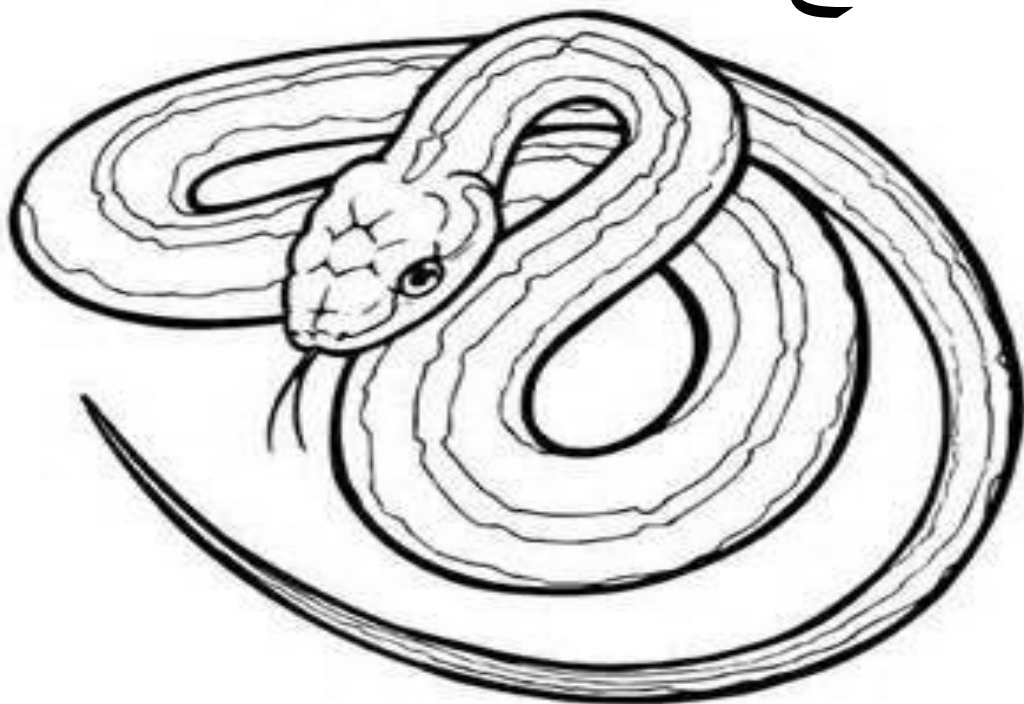
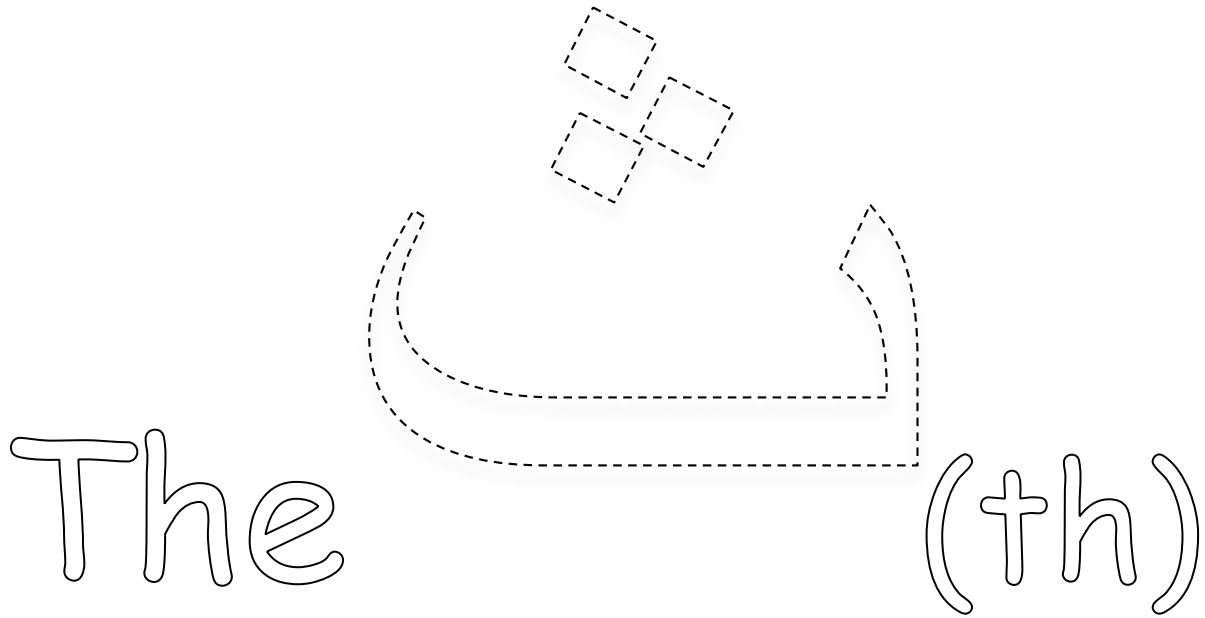

EXERCISE 29: LETTER RECOGNITION

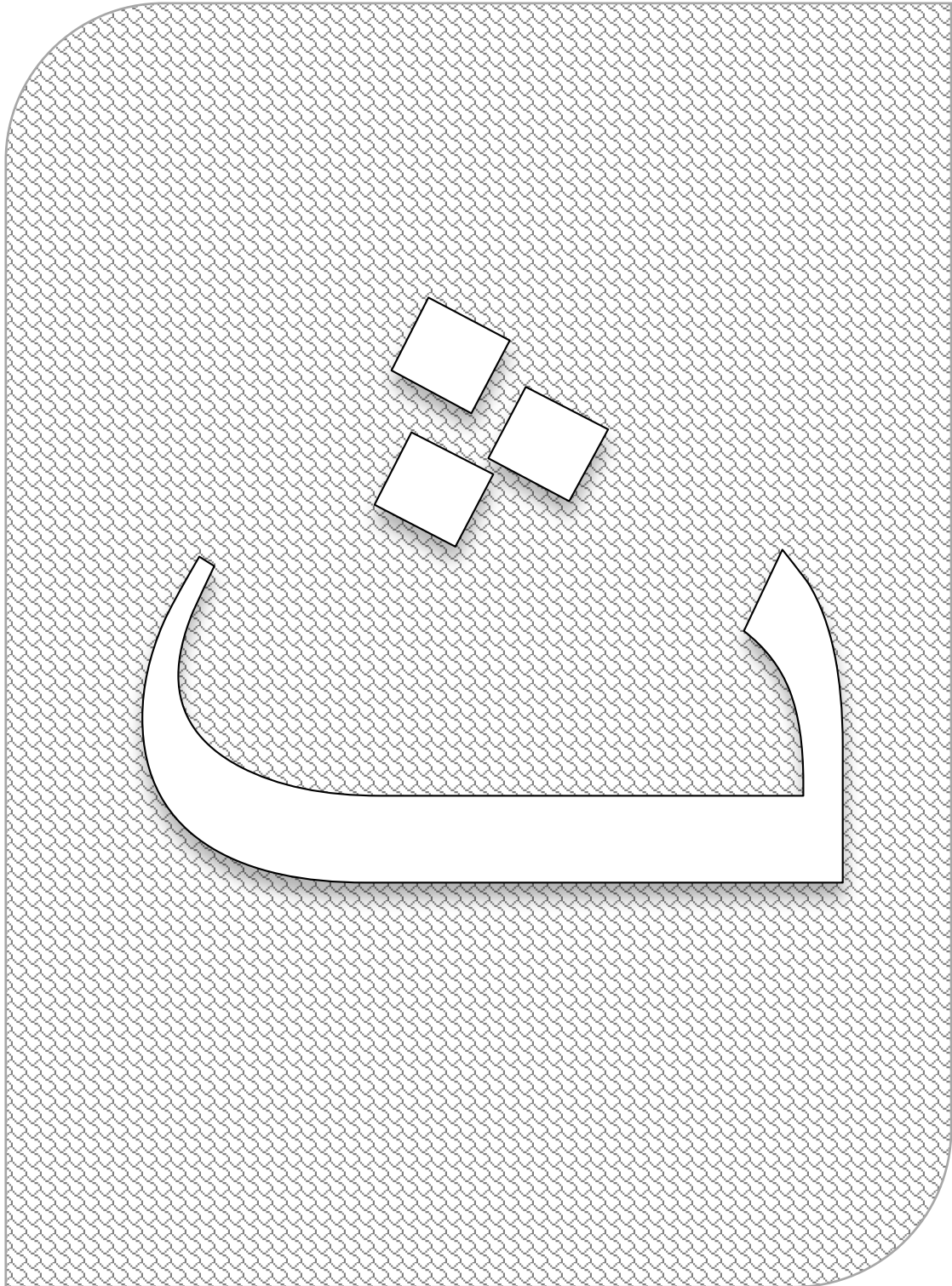

EXERCISE 30: LETTER RECOGNITION

Join the dots and write the letter

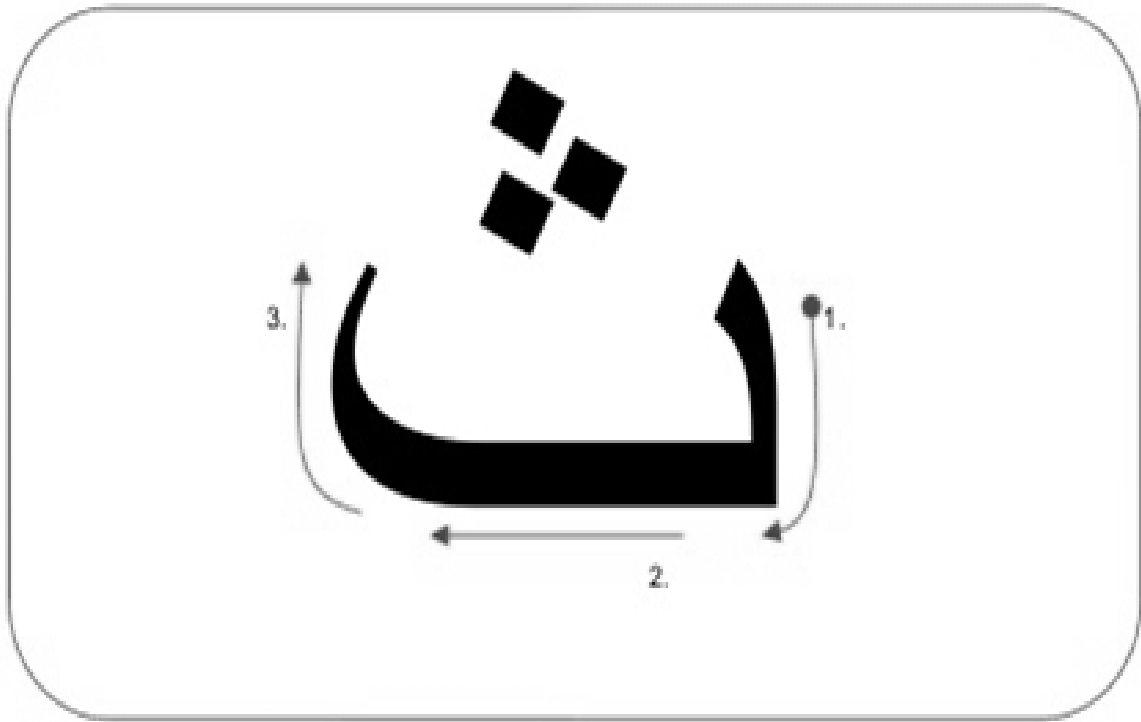

EXERCISE 31: LETTER RECOGNITION

Choose the matching letter below

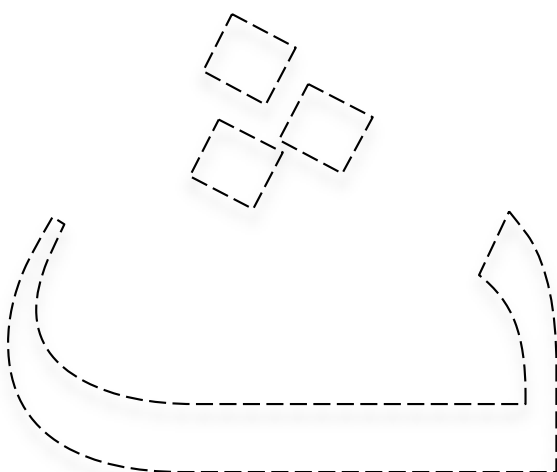
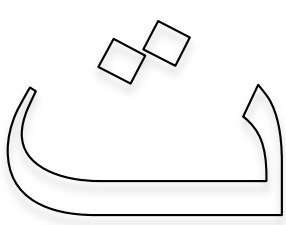
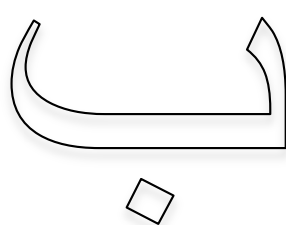
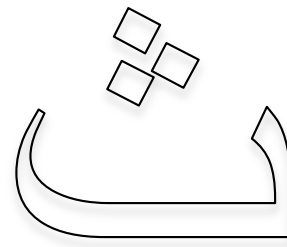





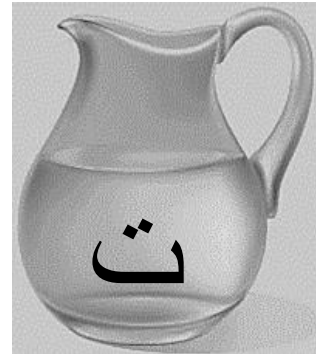



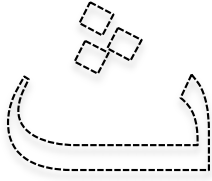
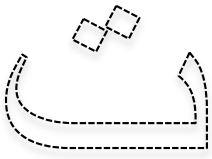
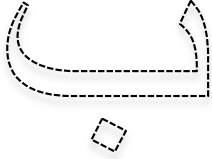

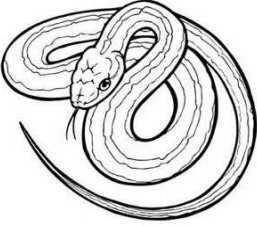
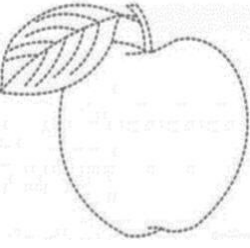
EXERCISE 32: RECOGNISING LETTERS

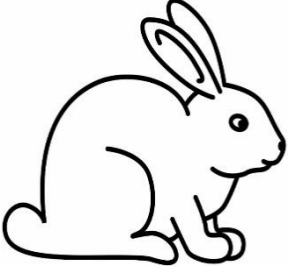
Join the matching letters

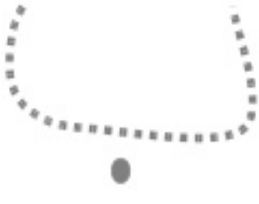

EXERCISE 33: WRITING EXERCISE

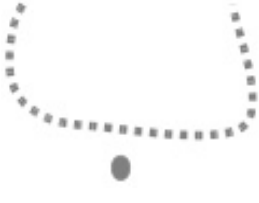
Join the dots and write the letter

<p>THE (th)</p>	<p>TE (ta)</p>	<p>BE (ba)</p>	<p>ALIF (a-Light)</p>
			
			
			
			

EXERCISE 34: JOIN THE MATCHING LETTERS

ا ا ت ت ت ت

EXERCISE 35: LETTER RECOGNITION

Jim

(ja)

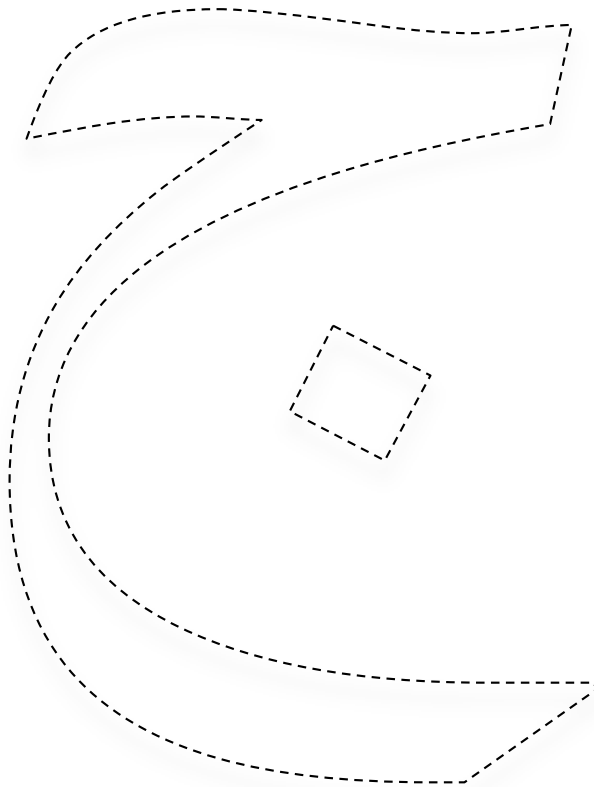

EXERCISE 36: LETTER RECOGNITION

Jim

(ja)

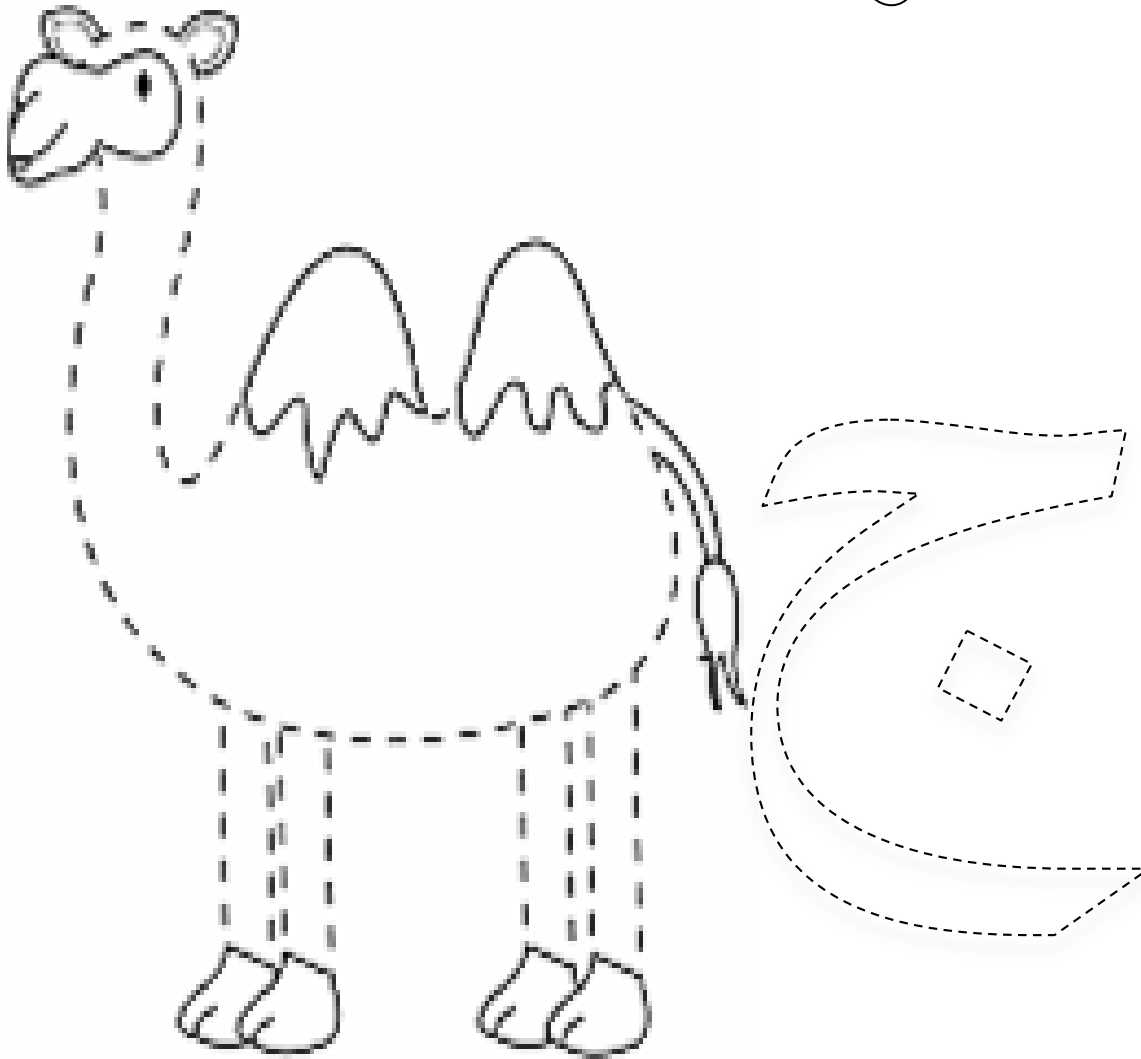

جَمَلٌ

EXERCISE 37: LETTER RECOGNITION

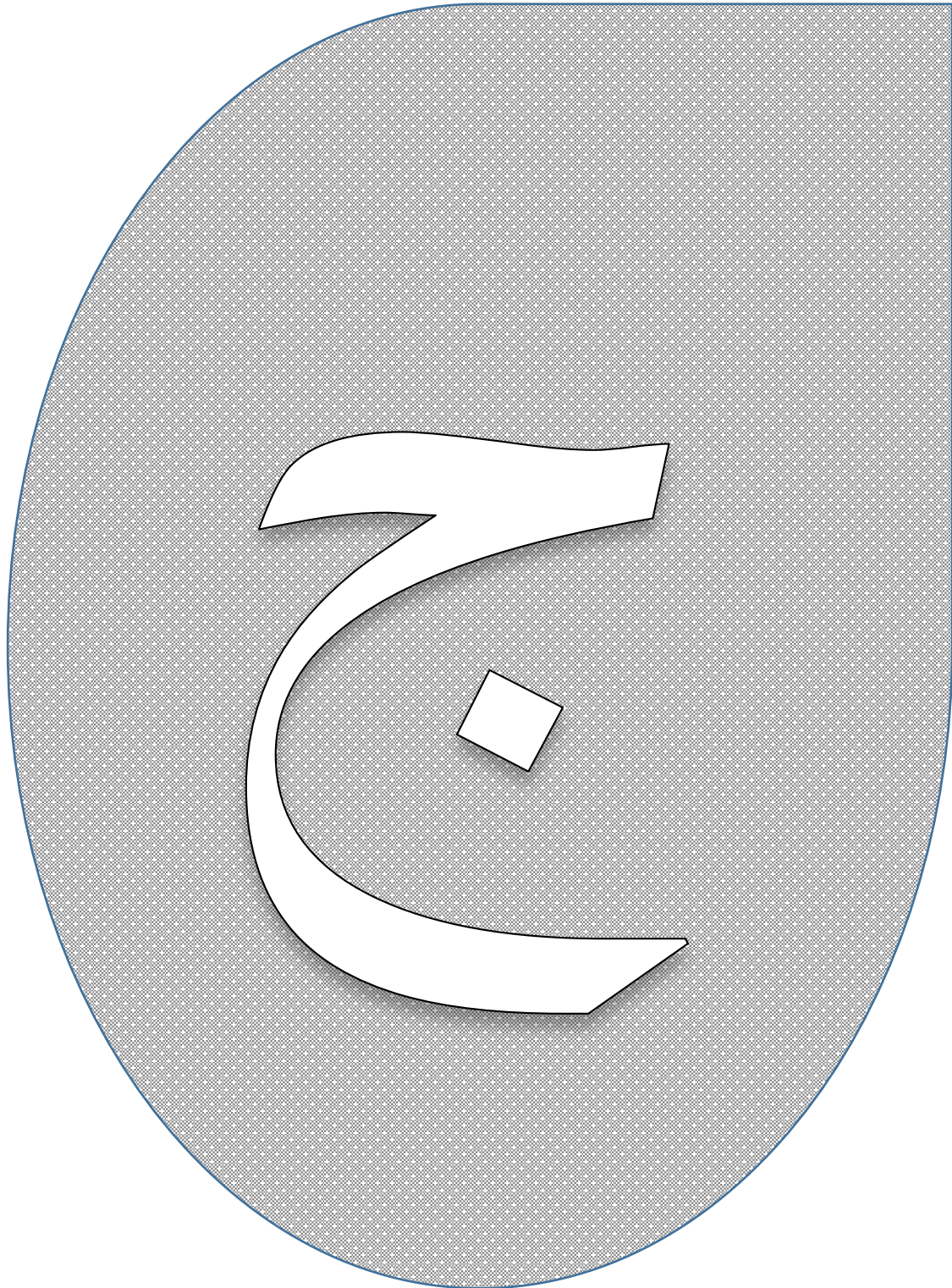

EXERCISE 38: LETTER RECOGNITION

Join the dots and write the letter

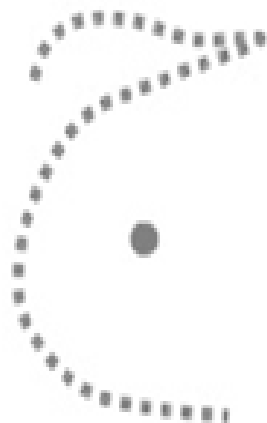
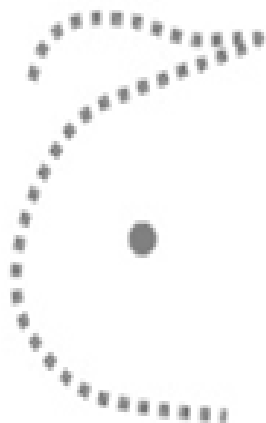
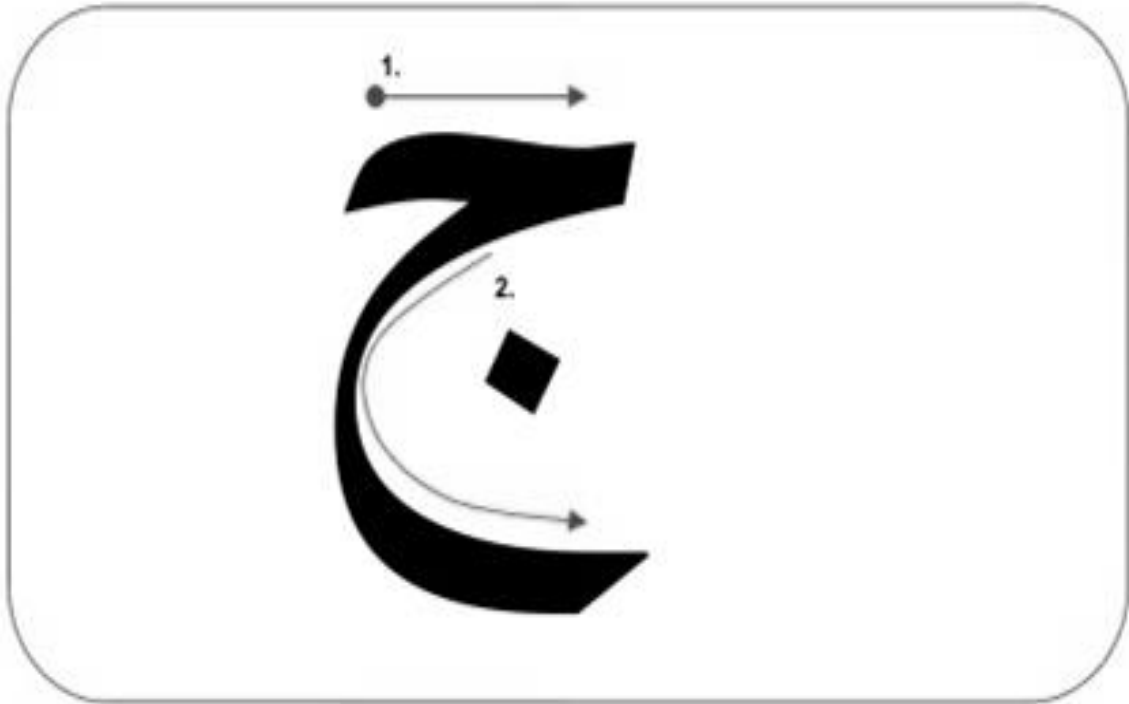

EXERCISE 39: LETTER RECOGNITION

Choose the matching letter below

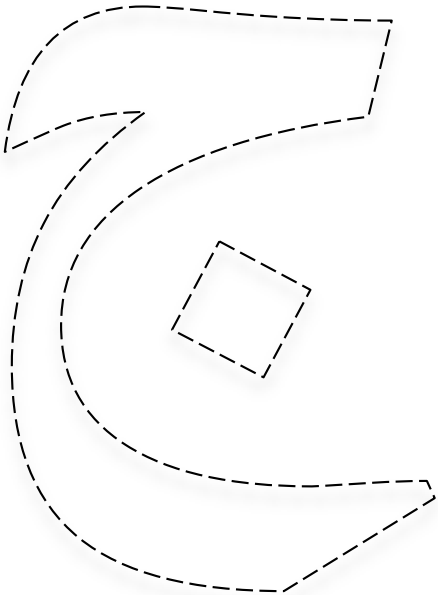
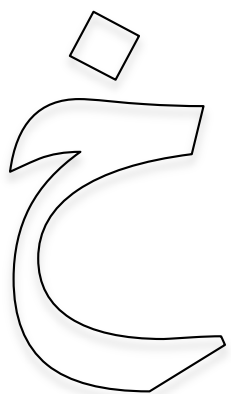
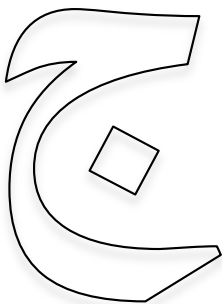
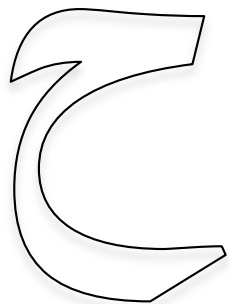
EXERCISE 40: LETTER RECOGNITION

Hai

(ha)

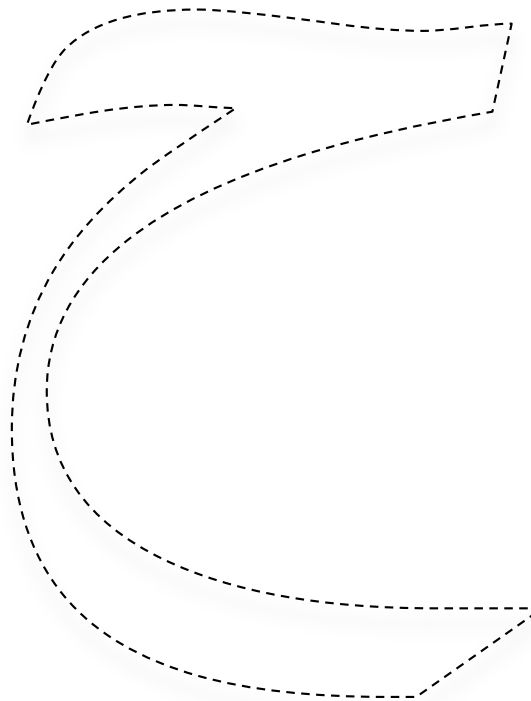

EXERCISE 41: LETTER RECOGNITION

Hai (ha)

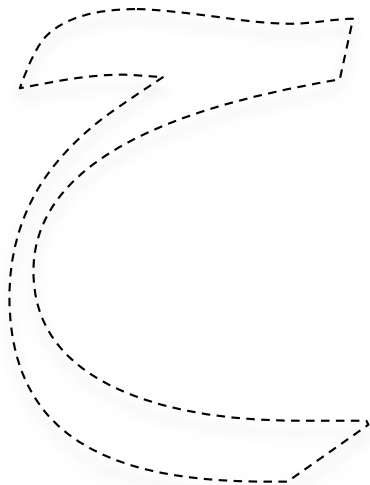

حَافِلَةٌ



EXERCISE 42: LETTER RECOGNITION

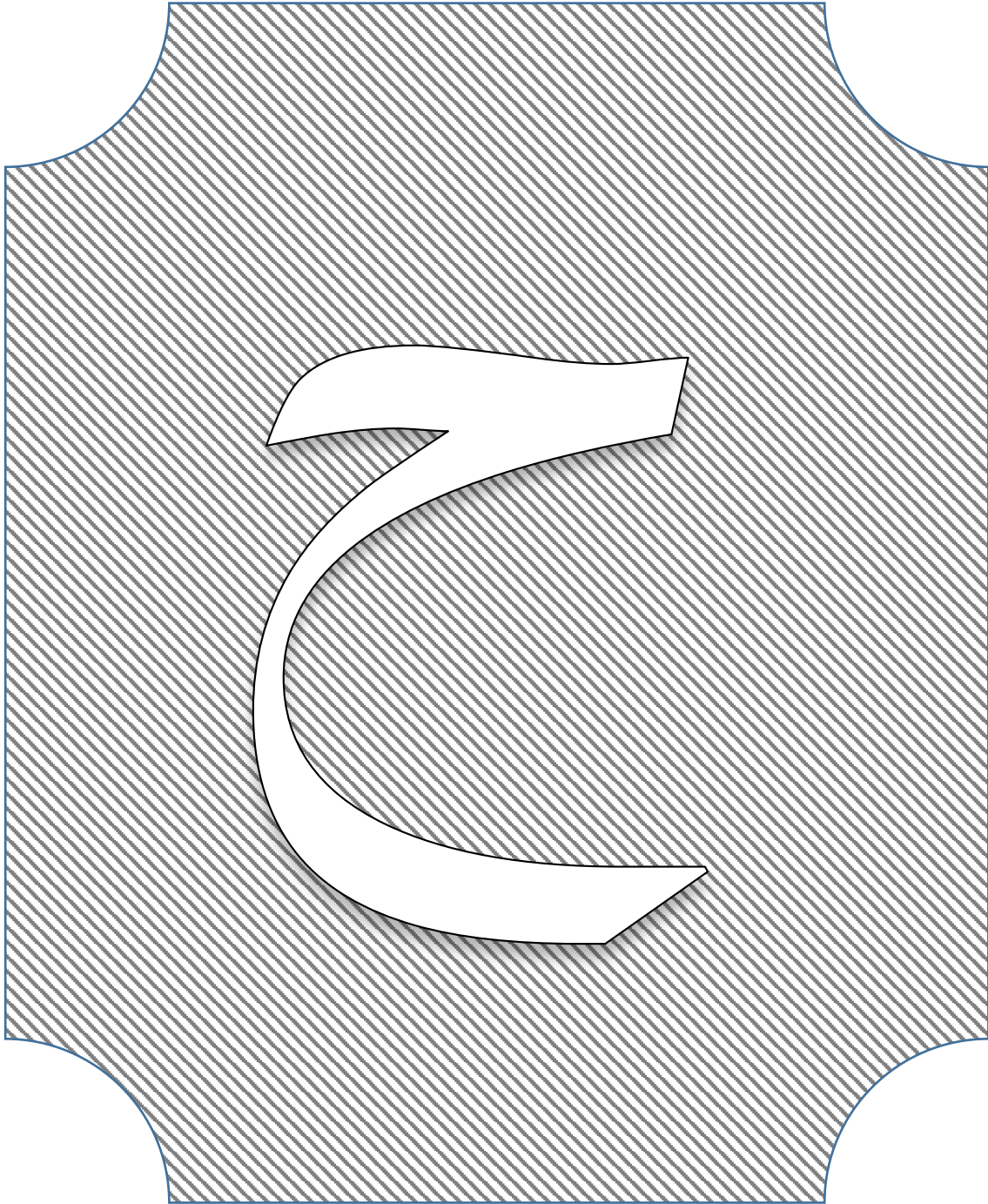

EXERCISE 43: LETTER RECOGNITION

Join the dots and write the letter

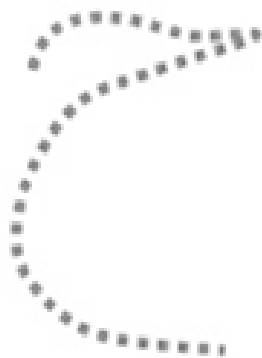
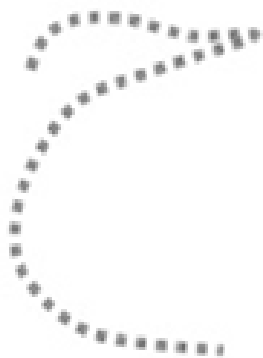
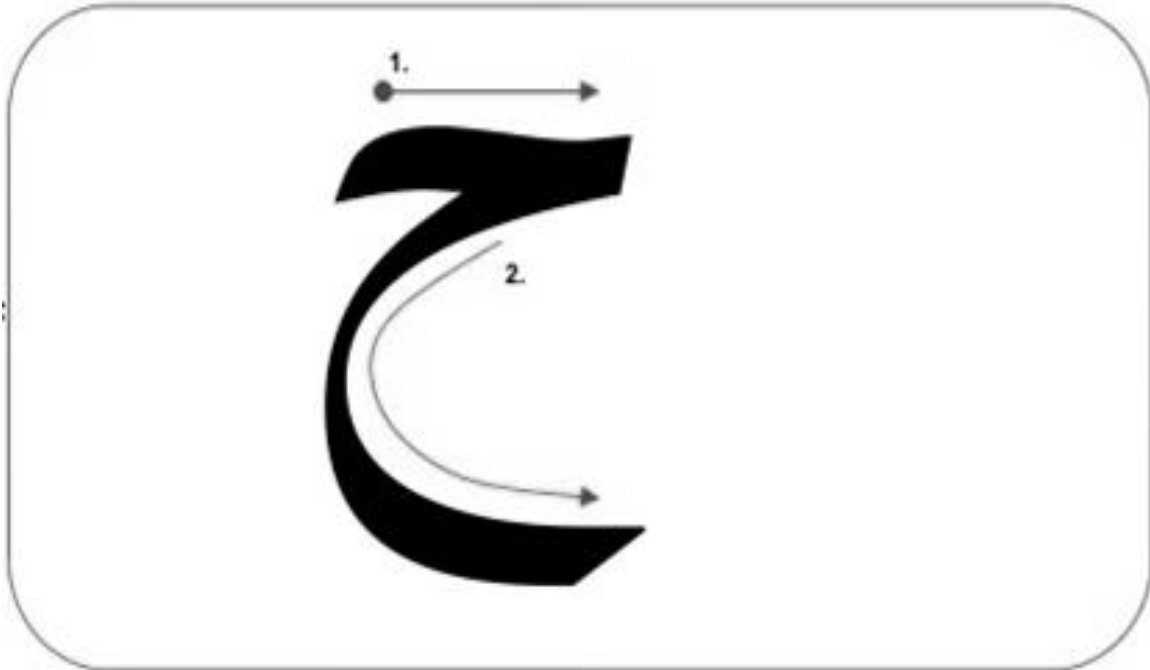

EXERCISE 44: LETTER RECOGNITION

Choose the matching letter below

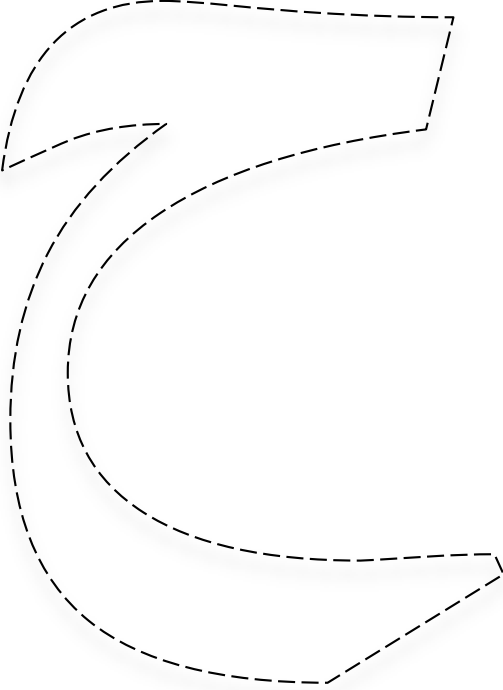
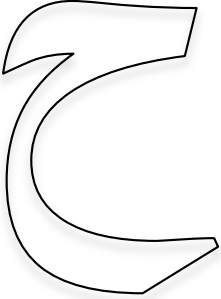
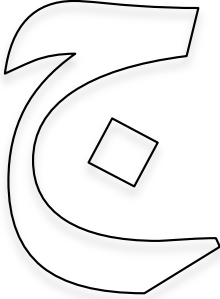
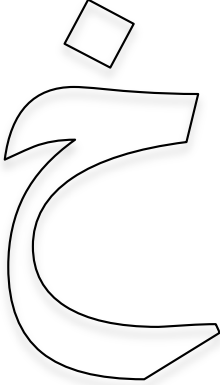
EXERCISE 45: LETTER RECOGNITION

Khai (kh)

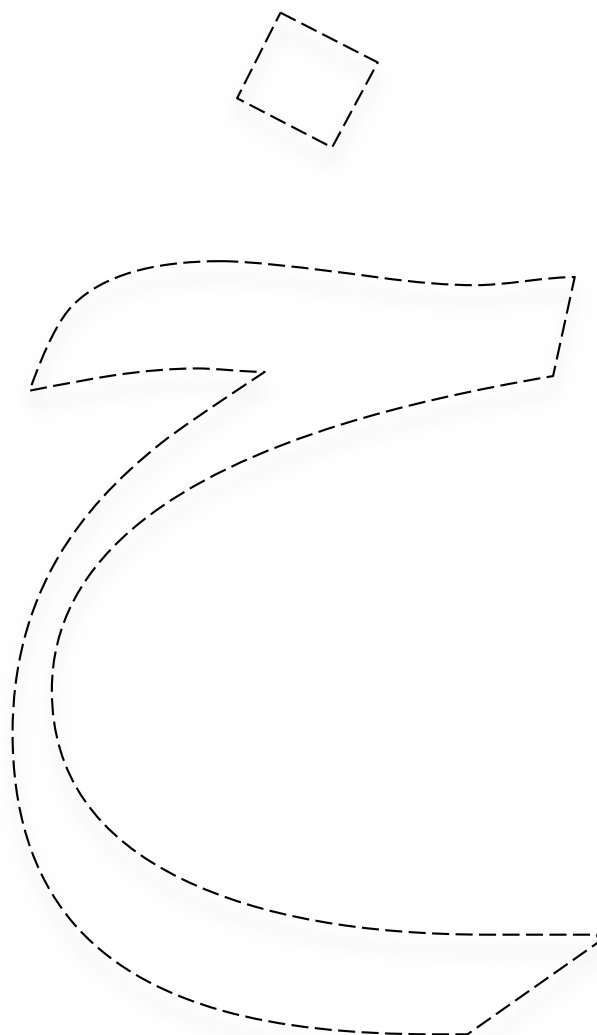

EXERCISE 46: LETTER RECOGNITION

Khai خ رُ و ف (kh)

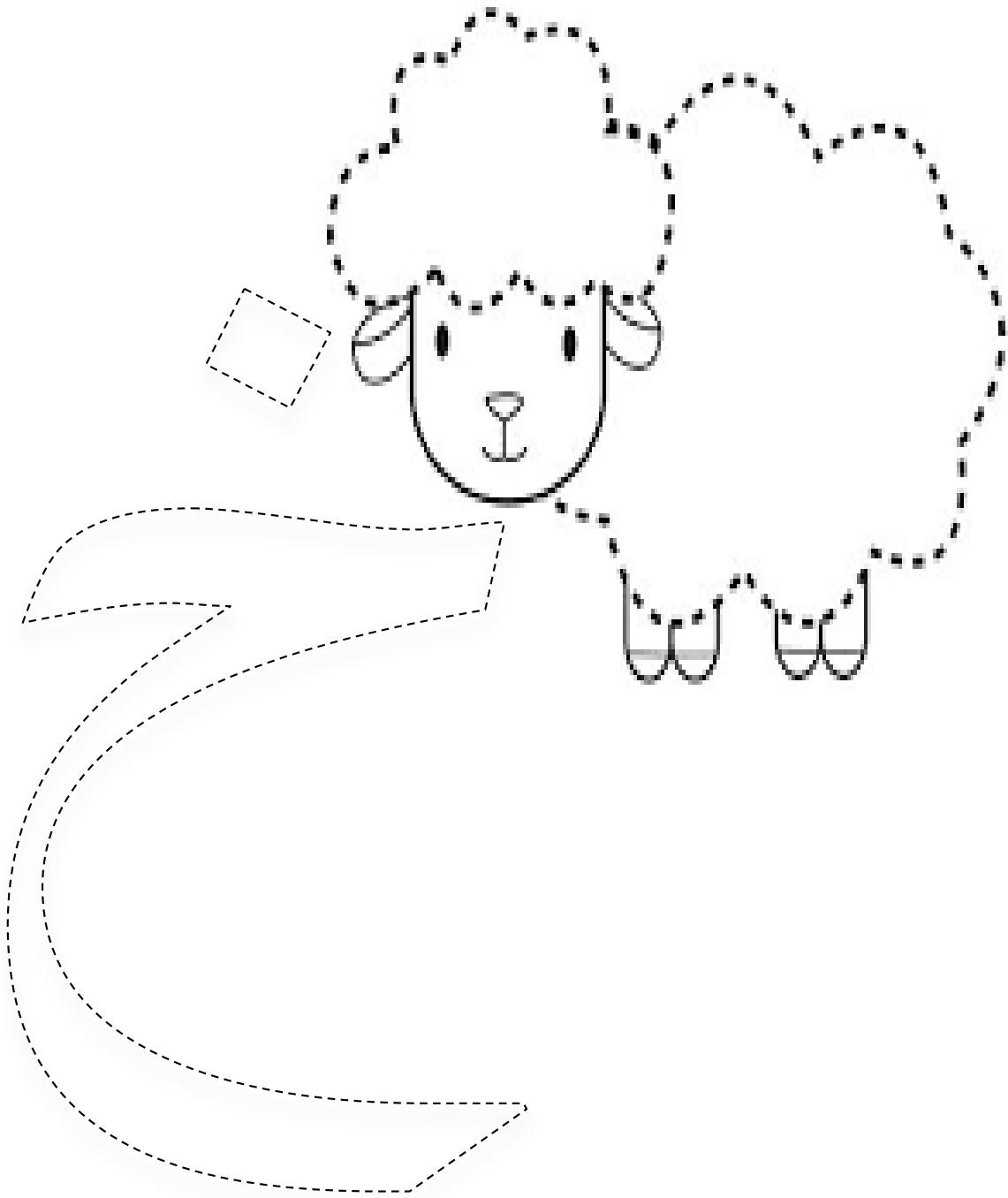

EXERCISE 47: LETTER RECOGNITION

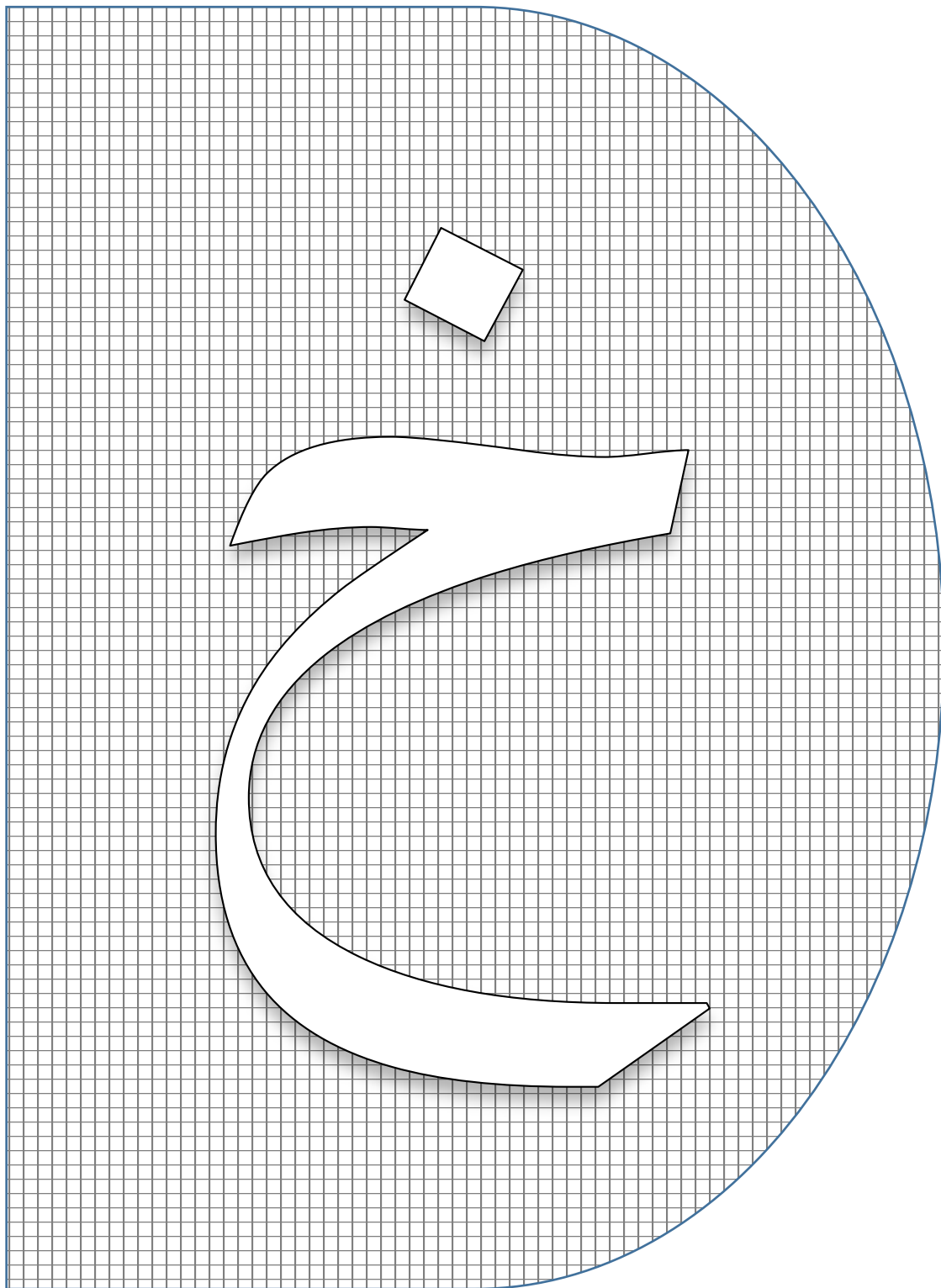

EXERCISE 48: LETTER RECOGNITION

Join the dots and write the letter

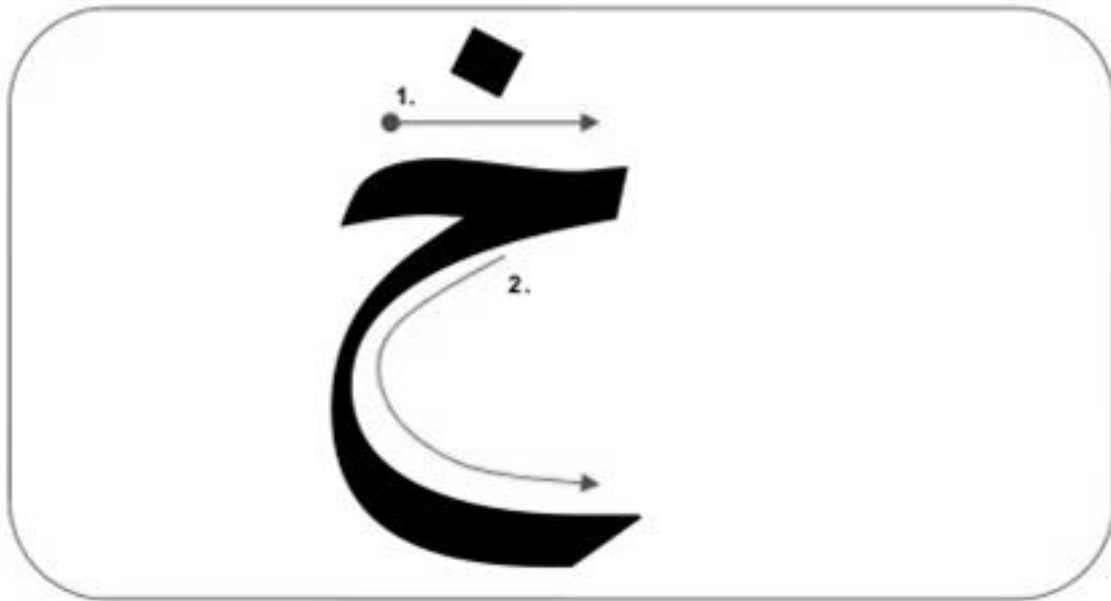

EXERCISE 49: LETTER RECOGNITION

Choose the matching letter below

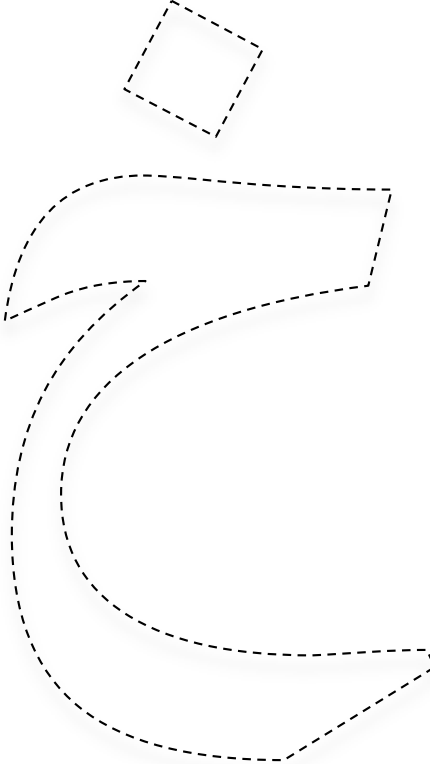
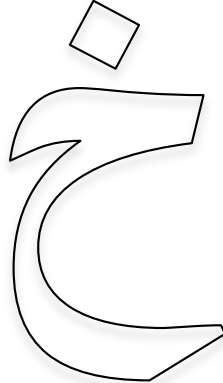
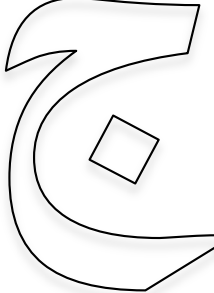
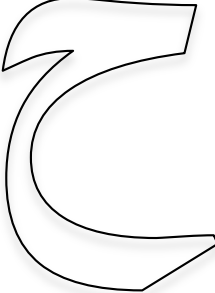





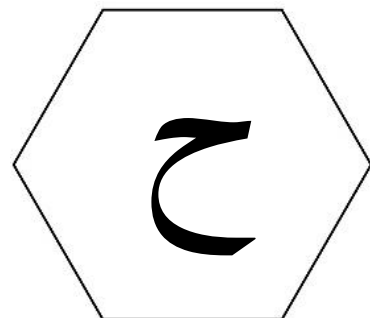
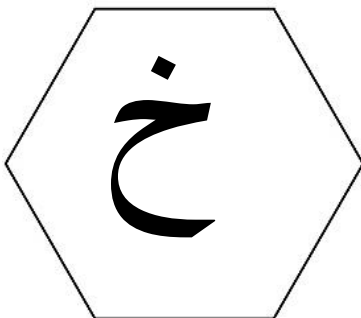
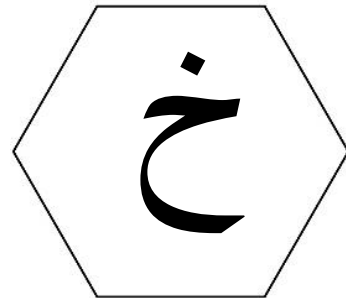
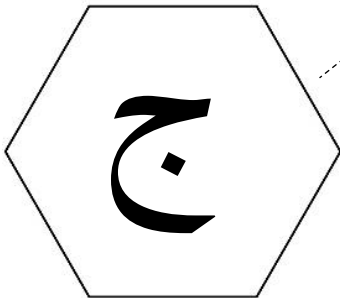
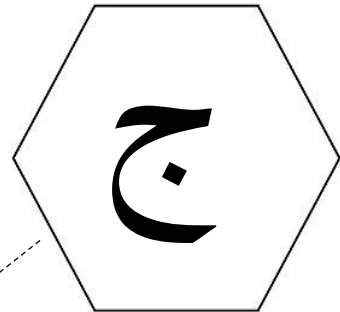
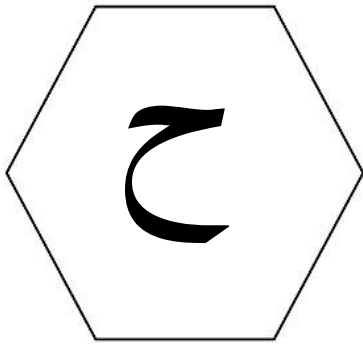

EXERCISE 50: RECOGNISING LETTERS

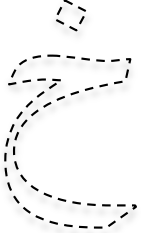
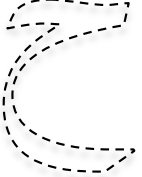
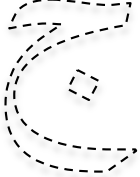
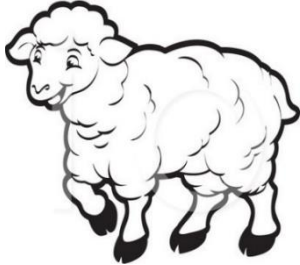
Join the matching letters

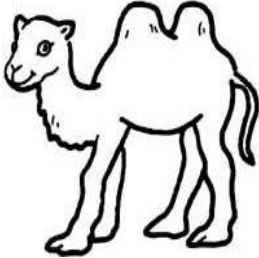

EXERCISE 51: WRITING EXERCISE

Join the dots and write the letter

<p>KHAI (kh)</p>	<p>HAI (ha-Light)</p>	<p>JIM (ja)</p>
		
		
		
		

EXERCISE 52: LETTER RECOGNITION

Join the matching letters

خ

ح

ح

ج

ج

خ

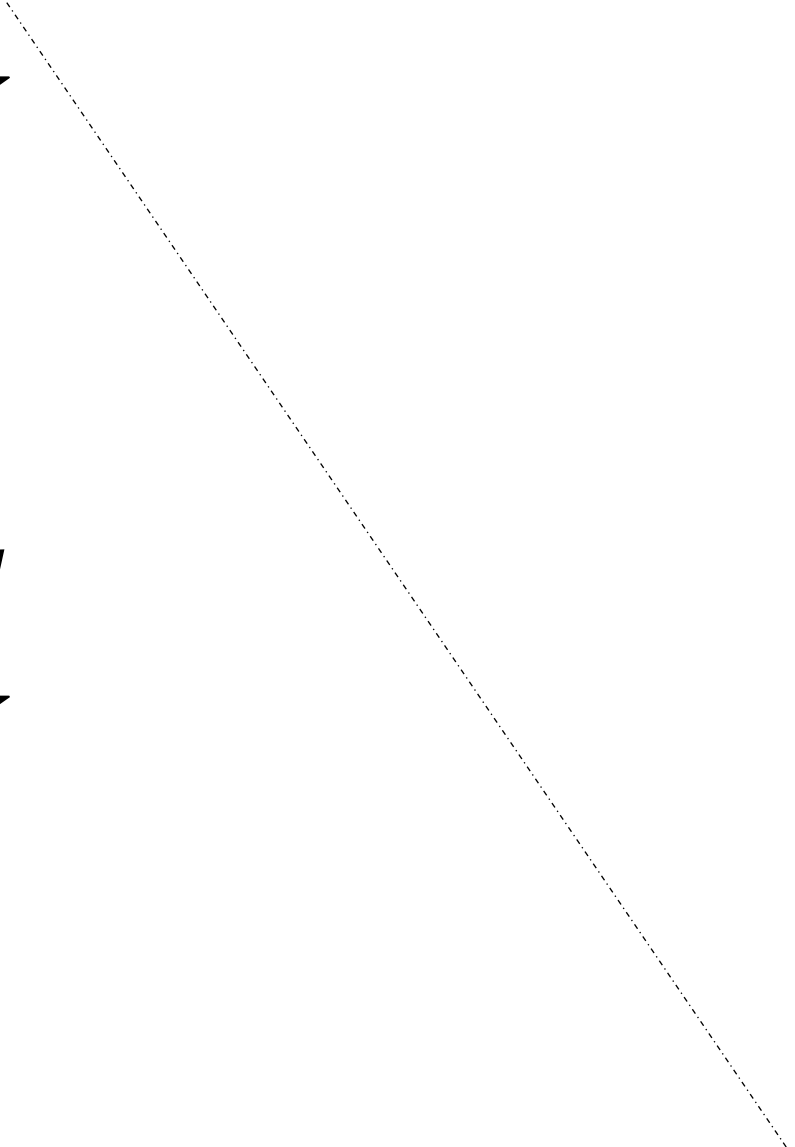

EXERCISE 53: JOIN THE MATCHING LETTERS

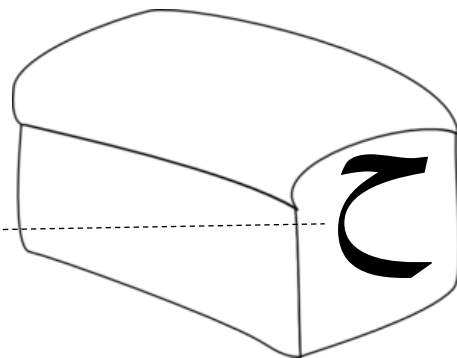
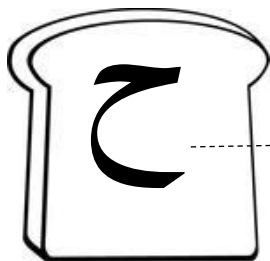
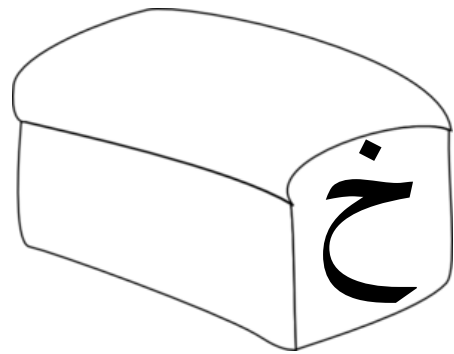
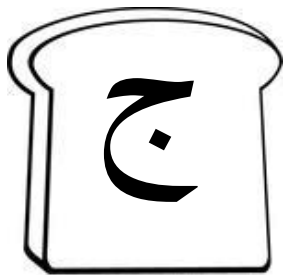
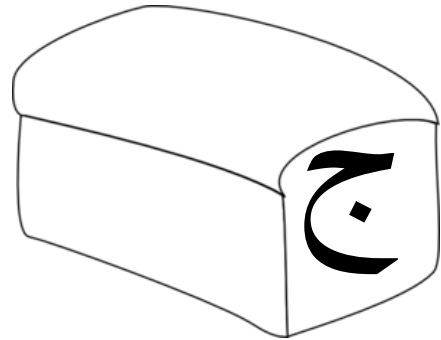
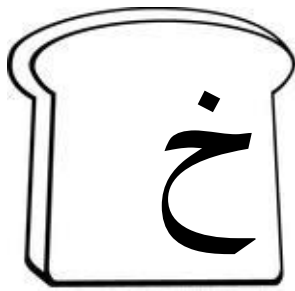

EXERCISE 54: LETTER RECOGNITION

Dal

(da)

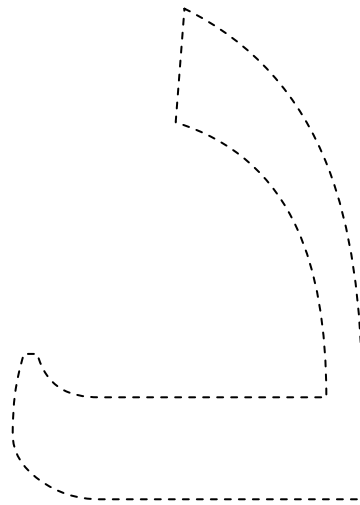

EXERCISE 55: LETTER RECOGNITION

Dal دِ يٰ ك (da)

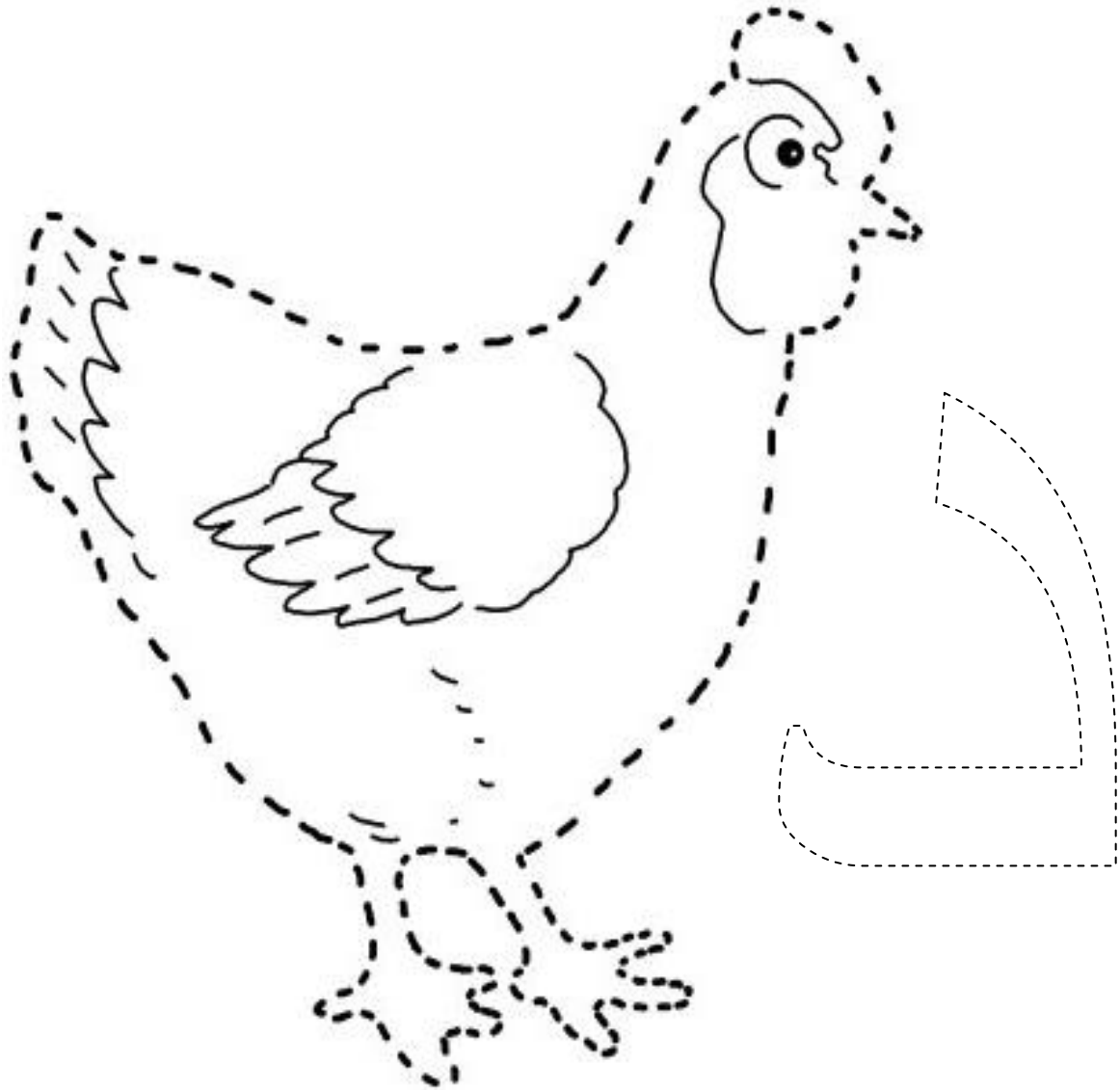

EXERCISE 56: LETTER RECOGNITION

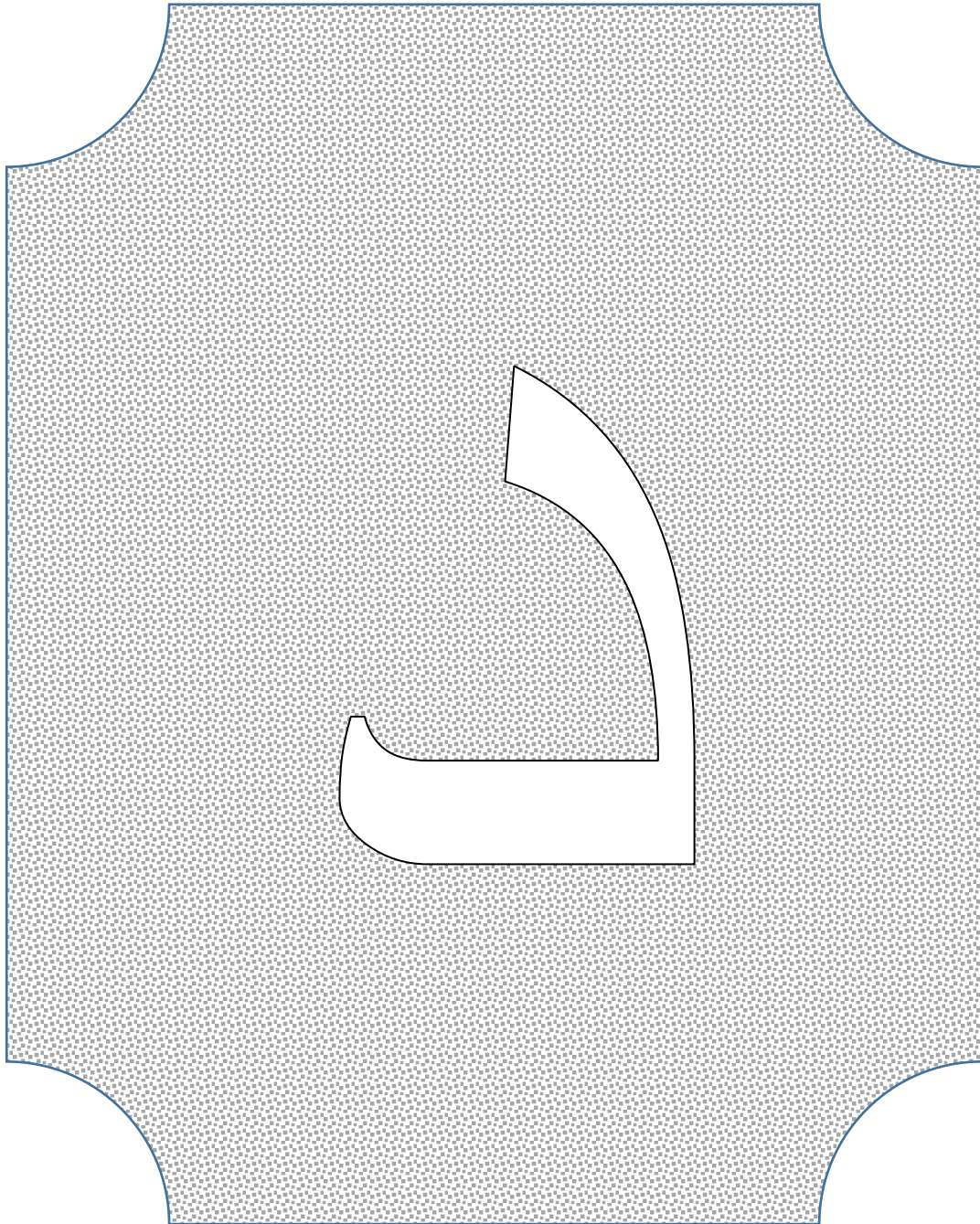

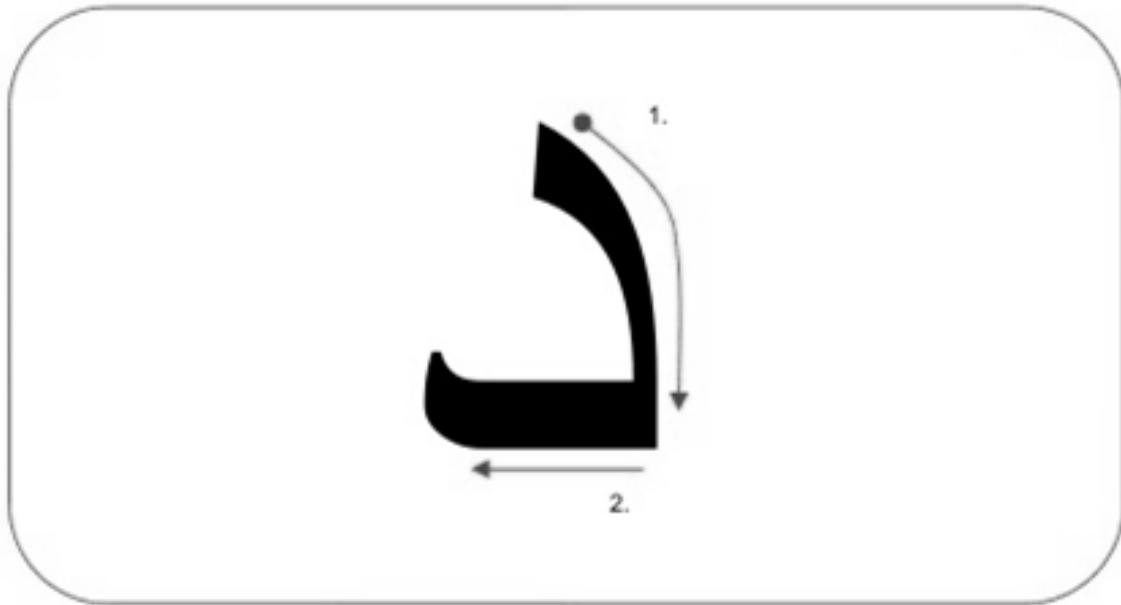

EXERCISE 57: LETTER RECOGNITION

Join the dots and write the letter

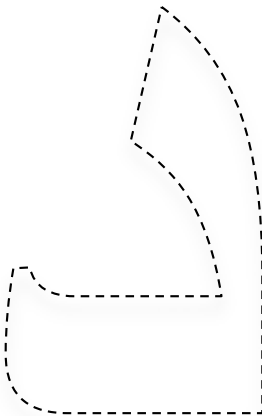
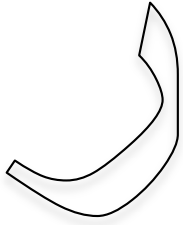

EXERCISE 58: LETTER RECOGNITION

Choose the matching letter below

EXERCISE 59: LETTER RECOGNITION

Dhal (dh)

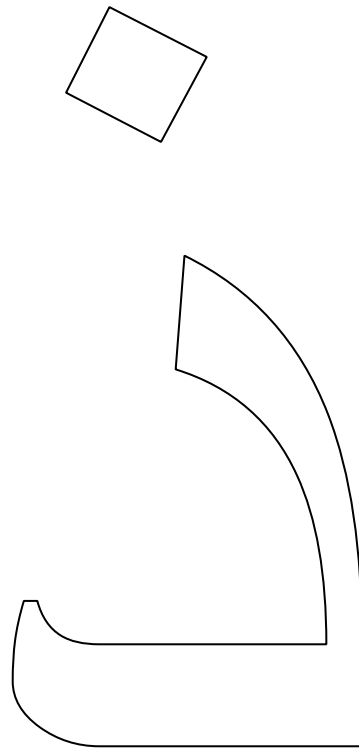

EXERCISE 60: LETTER RECOGNITION

ذُرَّةَ Dhal (dh)

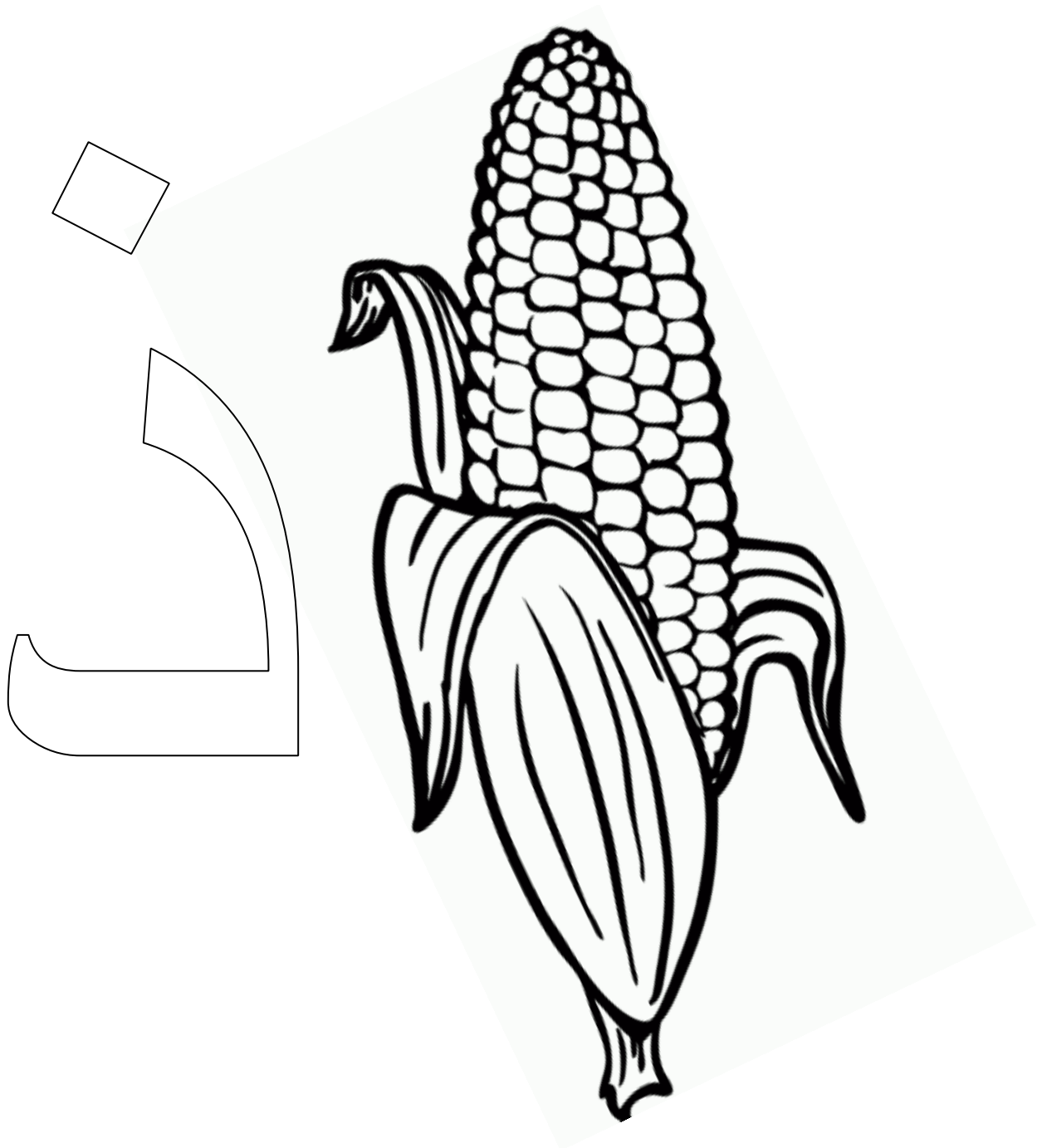

EXERCISE 61: LETTER RECOGNITION

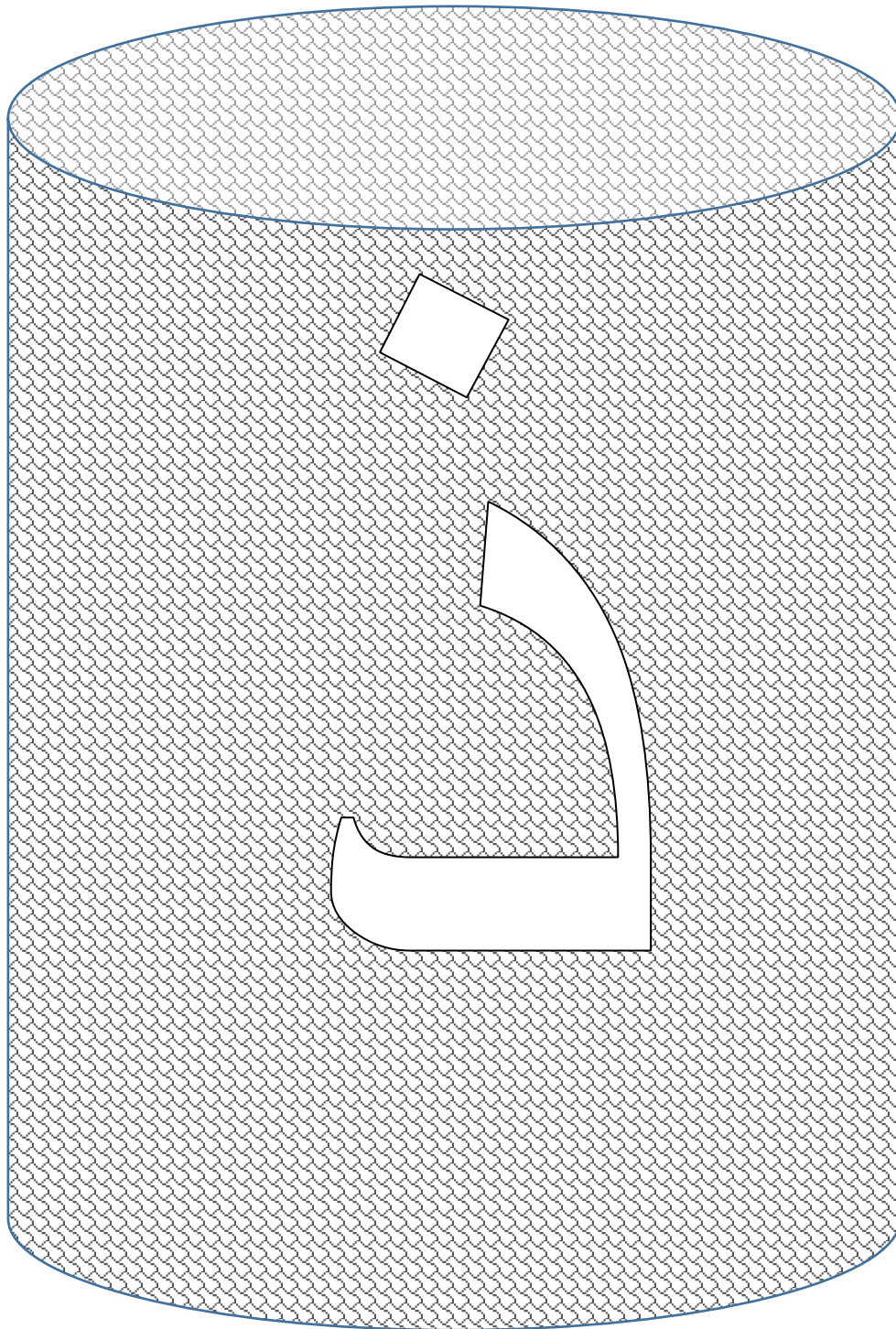

EXERCISE 62: LETTER RECOGNITION

Join the dots and write the letter

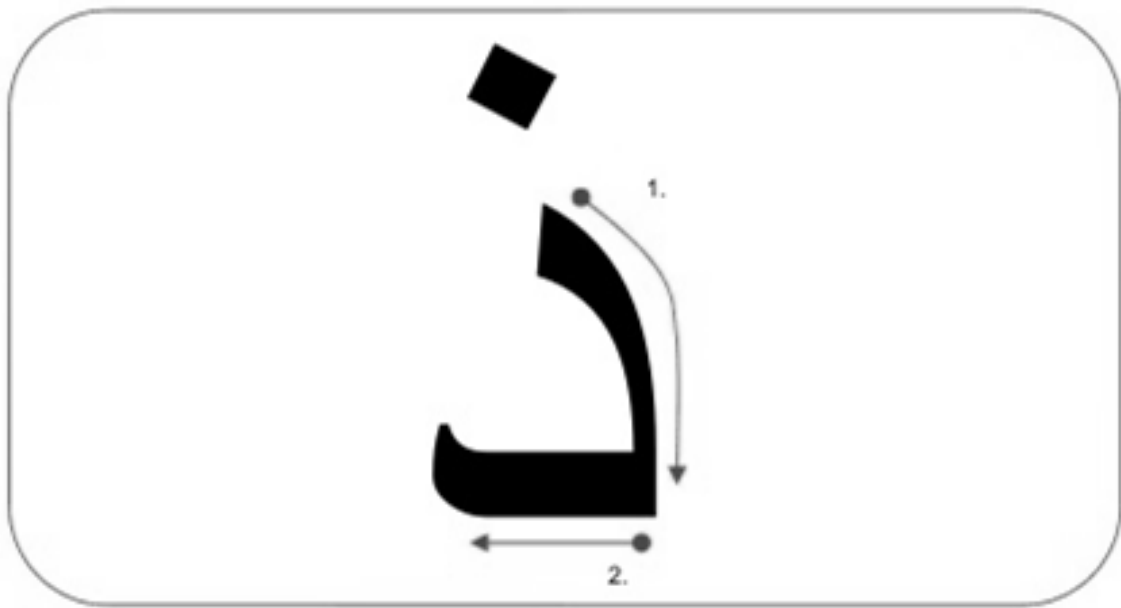

EXERCISE 63: LETTER RECOGNITION

Choose the matching letter below

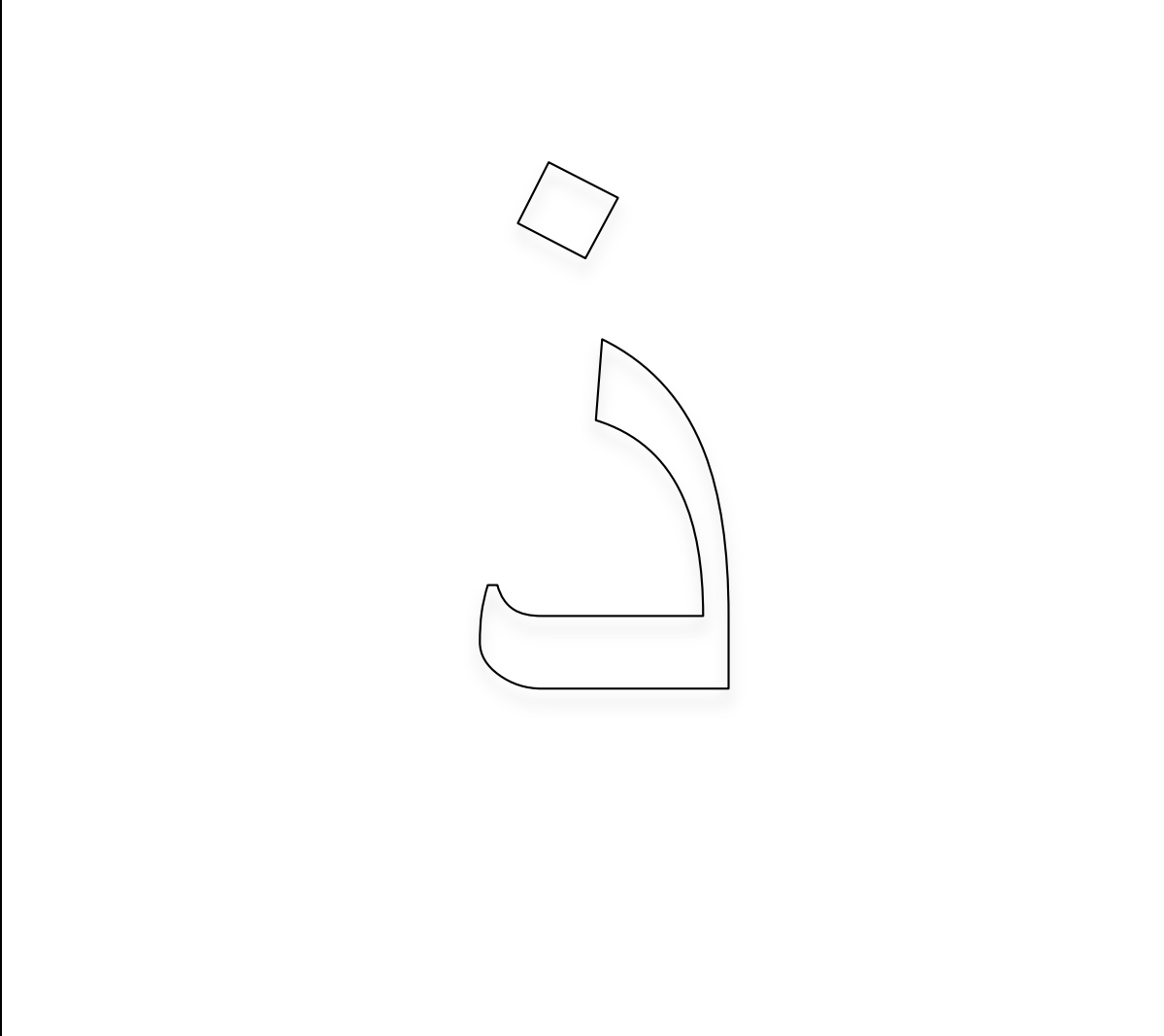
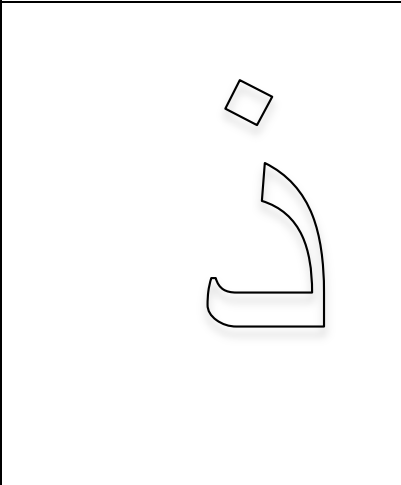
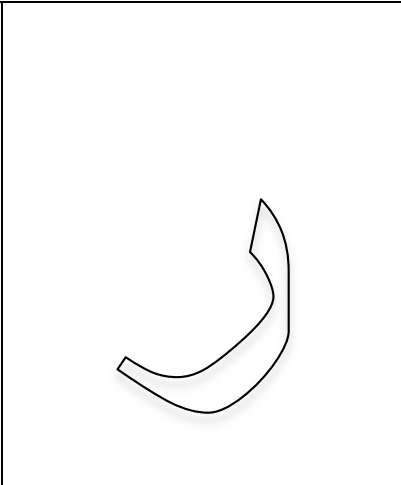
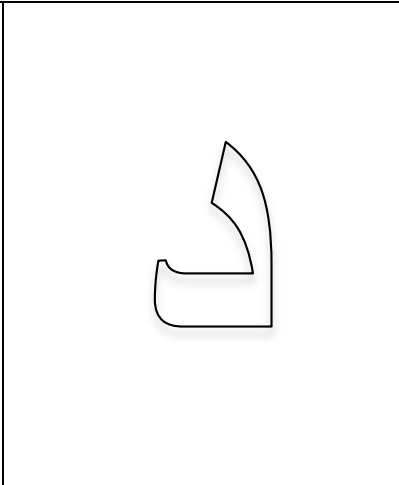
EXERCISE 64: LETTER RECOGNITION

RE

(ra)

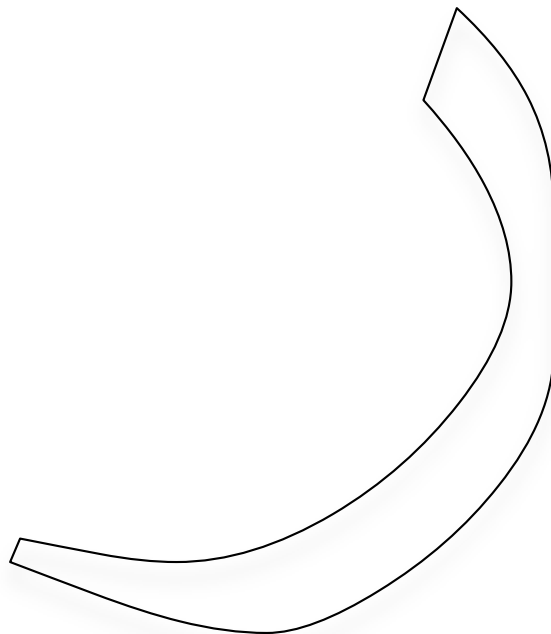

EXERCISE 65: LETTER RECOGNITION

RE

رَمَان

(ra)

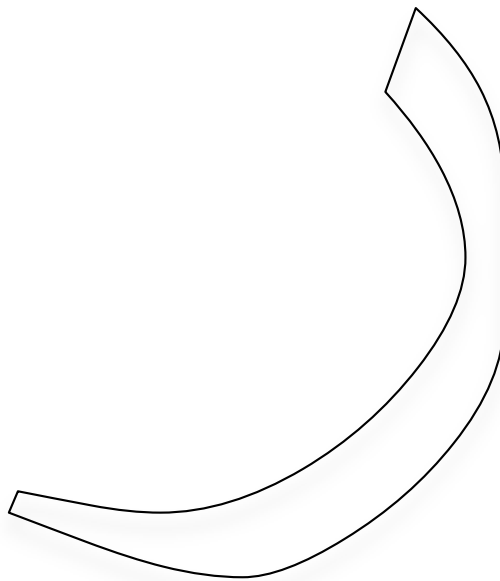
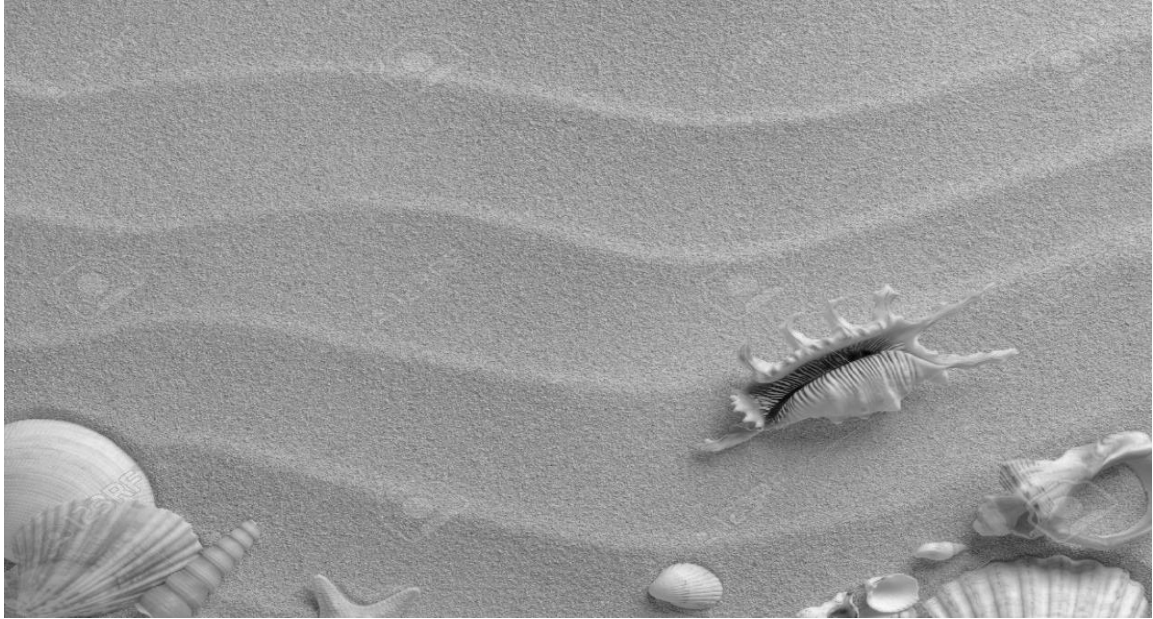

EXERCISE 66: LETTER RECOGNITION

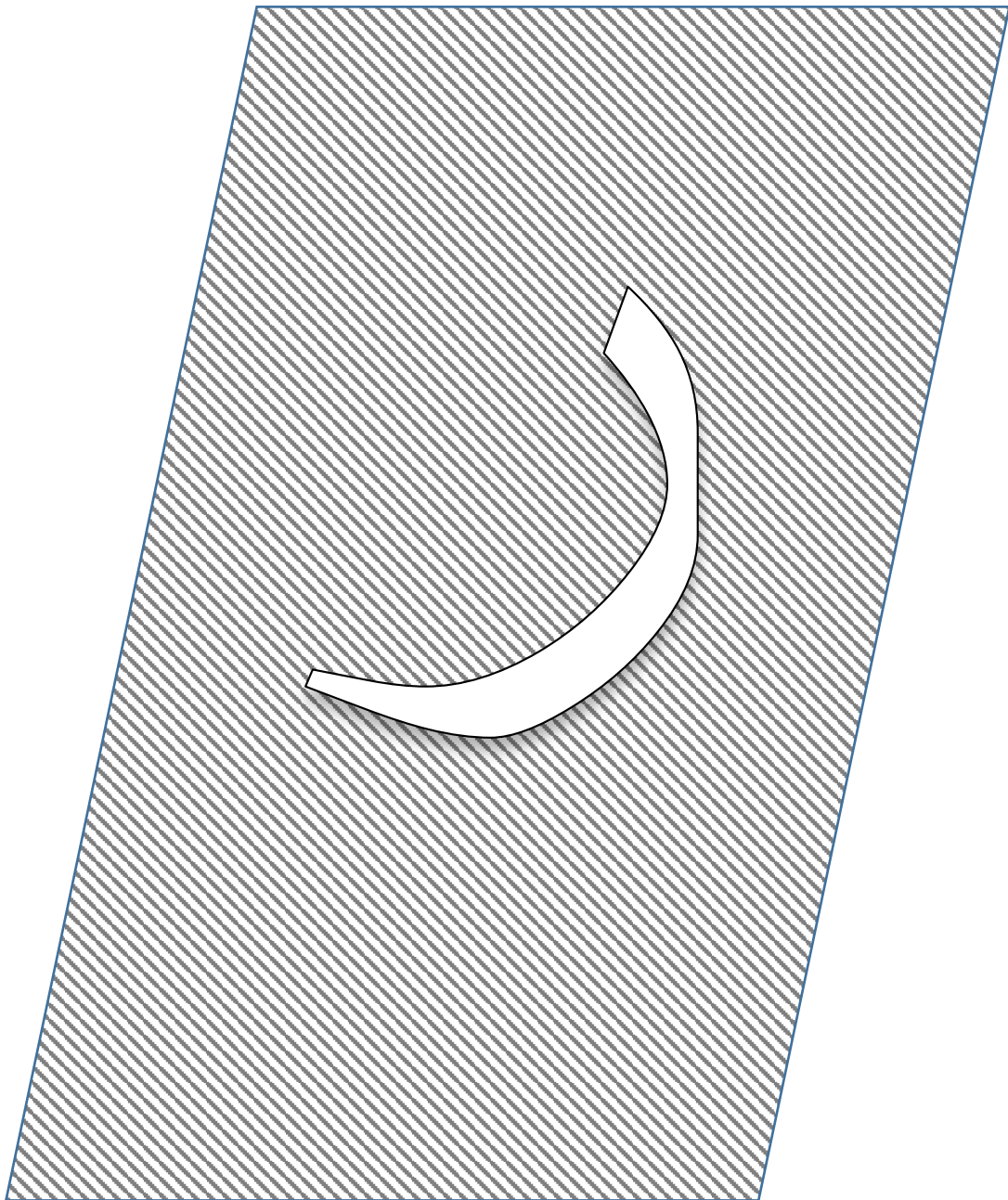

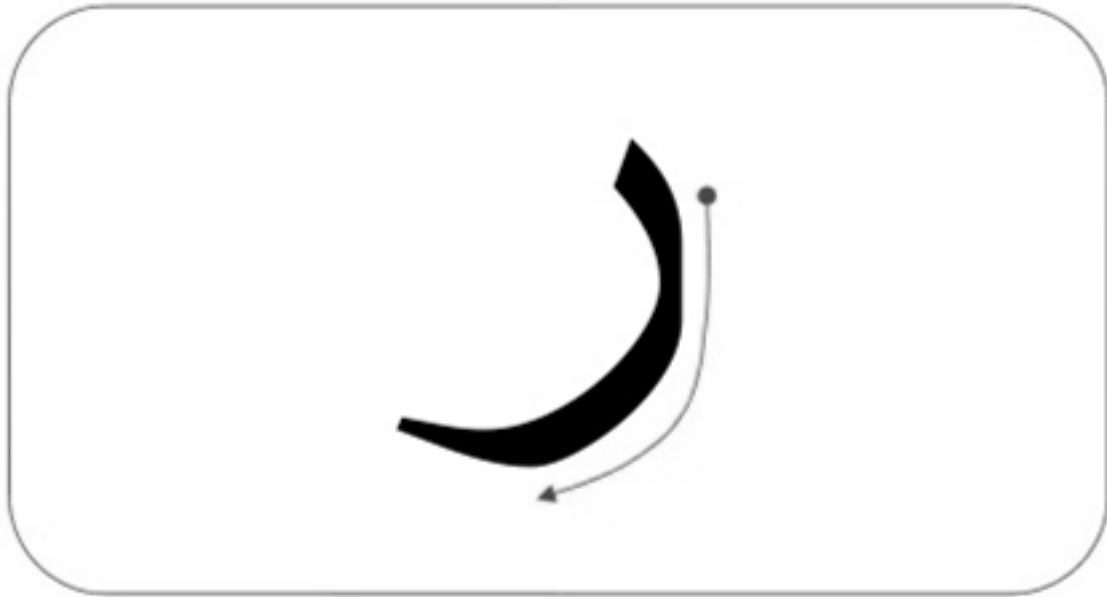

EXERCISE 67: LETTER RECOGNITION

Join the dots and write the letter

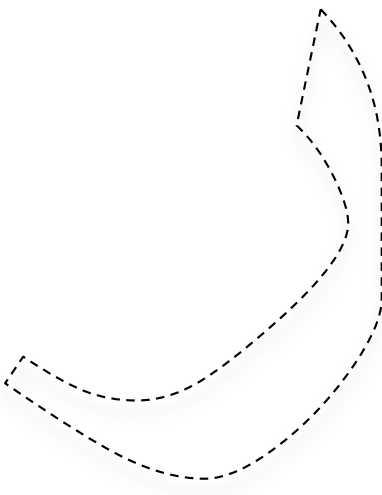

EXERCISE 68: LETTER RECOGNITION

Choose the matching letter below

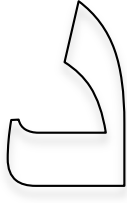
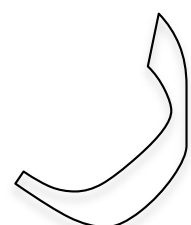
EXERCISE 69: LETTER RECOGNITION

Join the matching letters



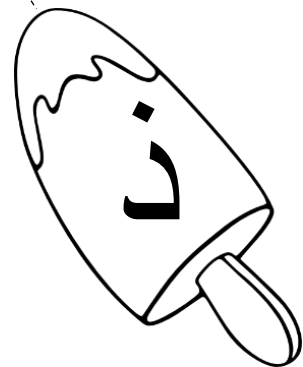
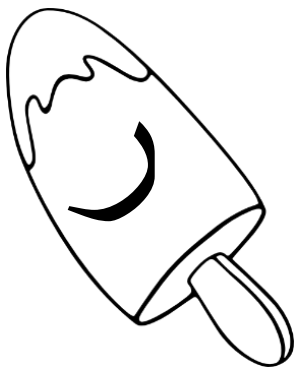
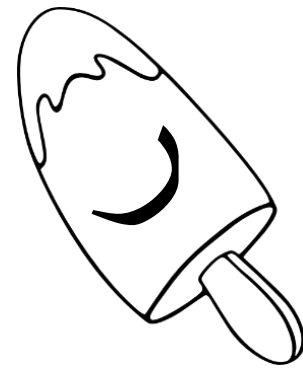
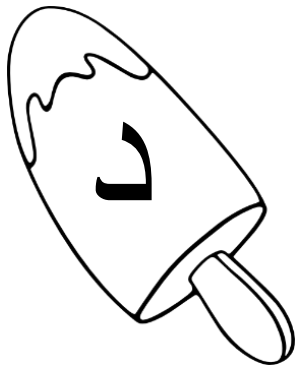
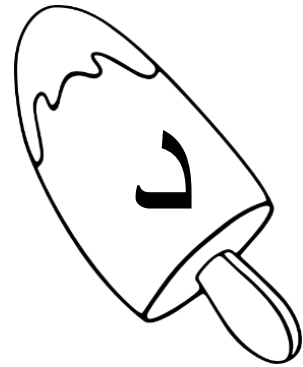
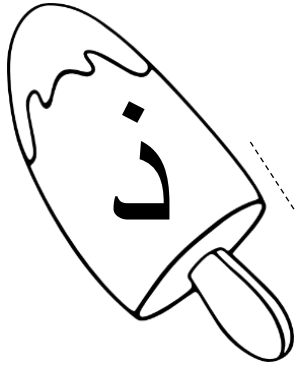



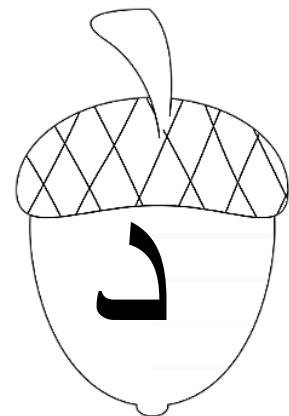
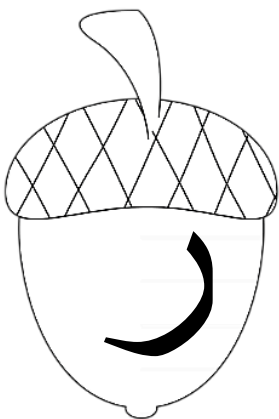
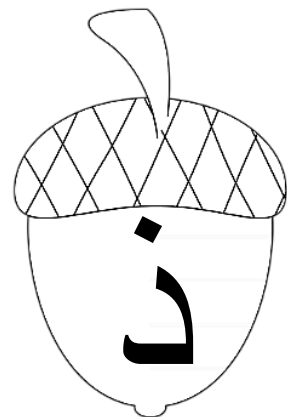
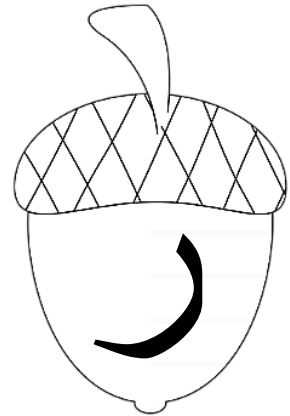
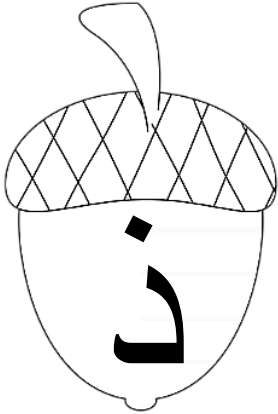

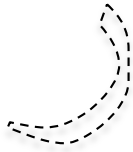

EXERCISE 70: LETTER RECOGNITION

Join the matching letters

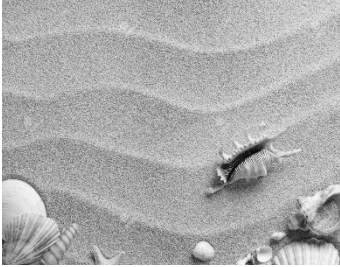
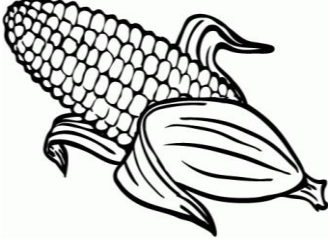
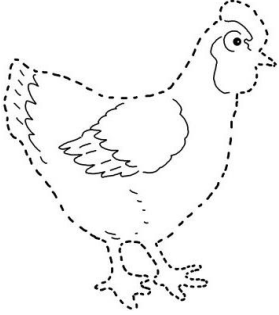

EXERCISE 71: WRITING EXERCISE

Join the dots and write the letter

<p>RE (ra)</p>	<p>DHAL (dh)</p>	<p>DAAL (da)</p>
		
		
		
		

EXERCISE 72: LETTER RECOGNITION

Join the matching letters

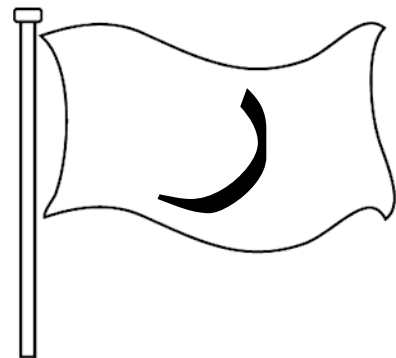
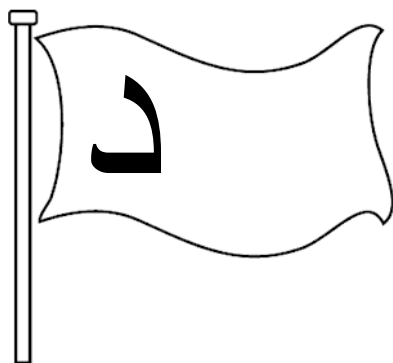
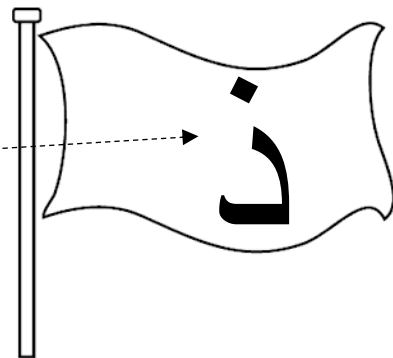
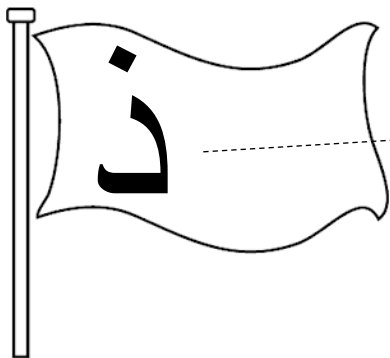
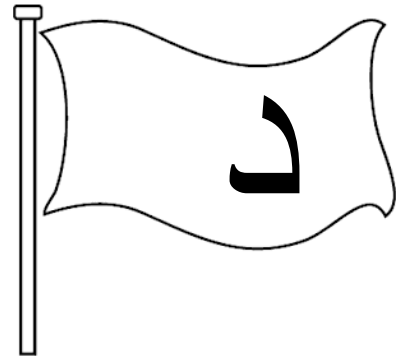
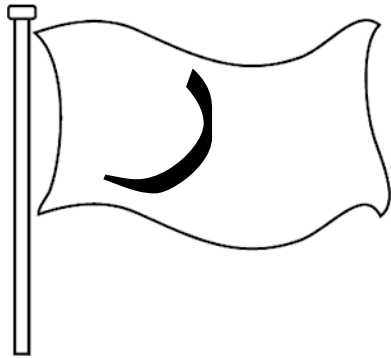

WHAT WE HAVE LEARNT IN CLASS KG

THE HURUFUL HIJAI - THE ARABIC ALPHABET

INTRODUCTION TO FIRST 10 ALPHABETS

ALIF TO RE - Letters and Sounds

ج	ث	ت	ب	ا
Jim (ja)	The (th)	Te (ta)	Be (ba)	Alif (a - Light)
ر	ذ	د	خ	ح
Re (ra)	Dhal (dh)	Dal (da)	Khai (kh)	Hai (ha - Light)

All the sounds covered so far have been put together into the next exercise. Make sure all the sounds are pronounced correctly. Repeat these exercises as many times as necessary to improve understanding, fluency, makharij and confidence of the student.

Teacher/ Parent Note: Exercise 72 brings us to the end of the Syllabus for Class KG. Try the Exercises 73 to 84 below and test the student and see if they have grasped all that has been taught so far. Congratulate the student on this big achievement and encourage them to aim higher. Please ensure that the child is completely confident and can recognize all the letters, before proceeding to the next level.

EXERCISE 73: READING ALPHABETS ALIF - RE

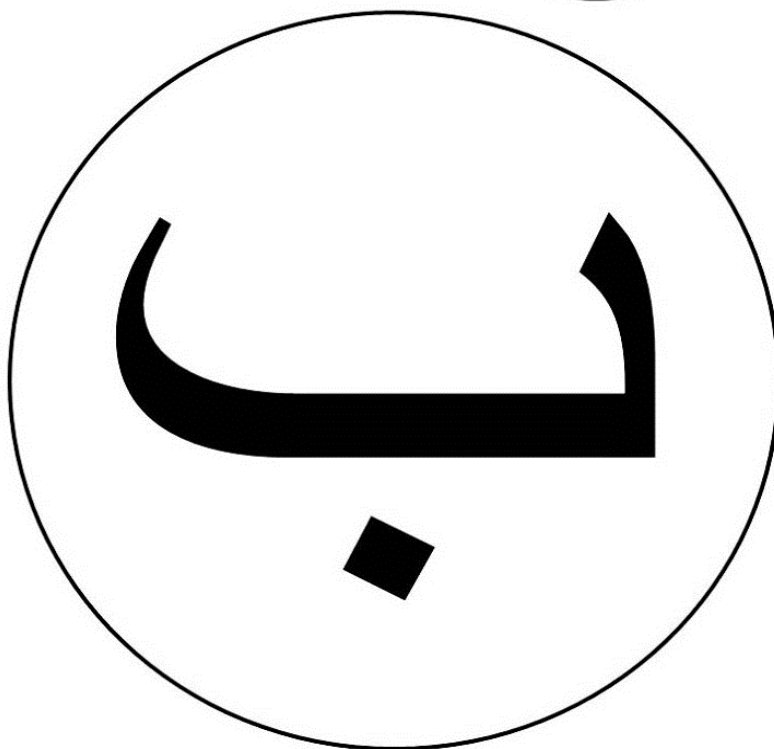
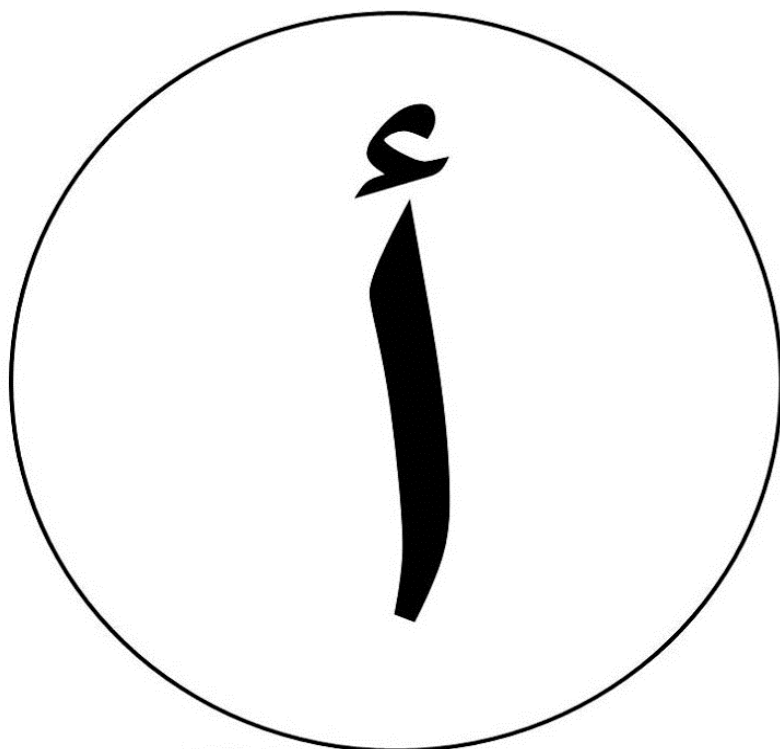

EXERCISE 74: LETTER RECOGNITION

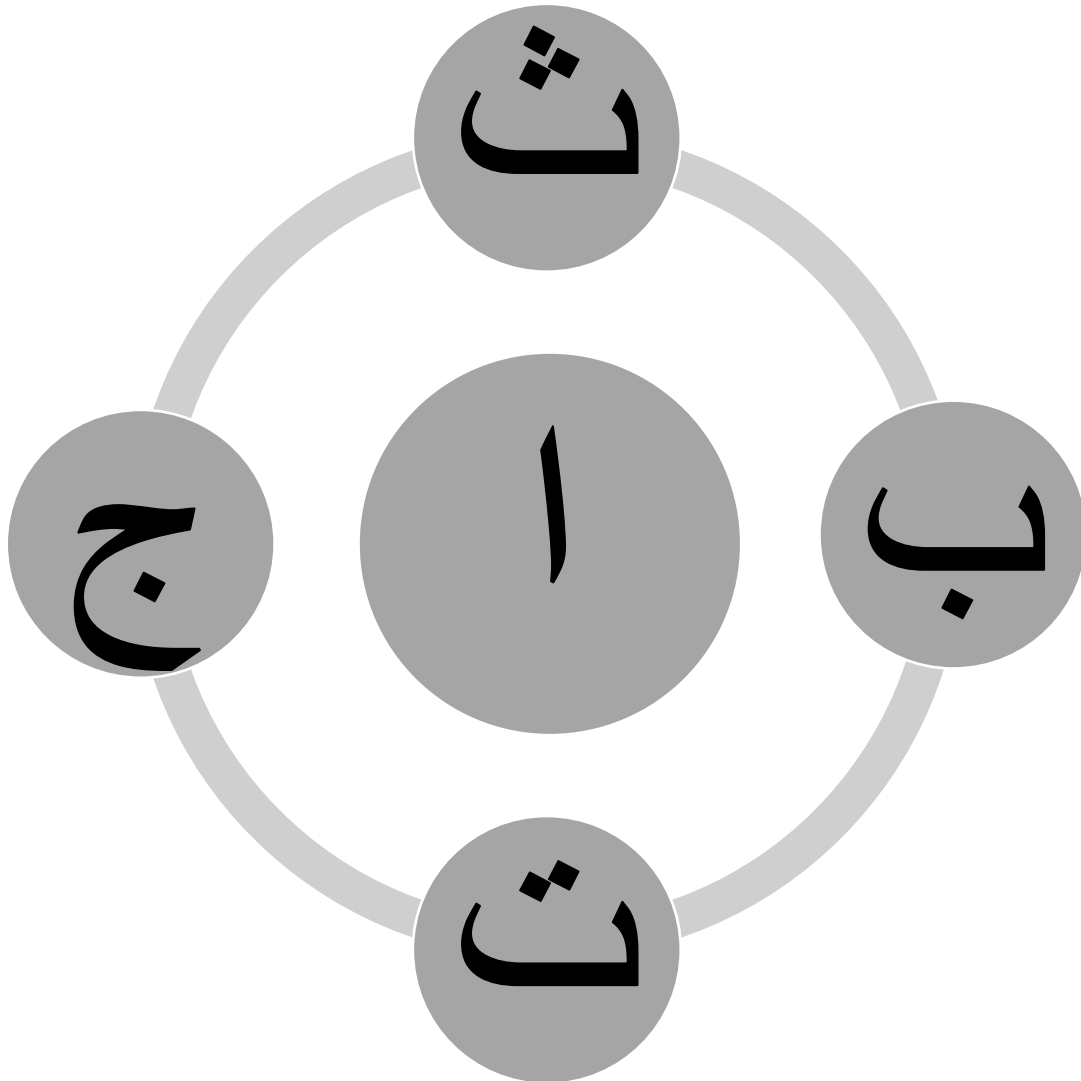

EXERCISE 75: READING ALPHABETS ALIF - RE

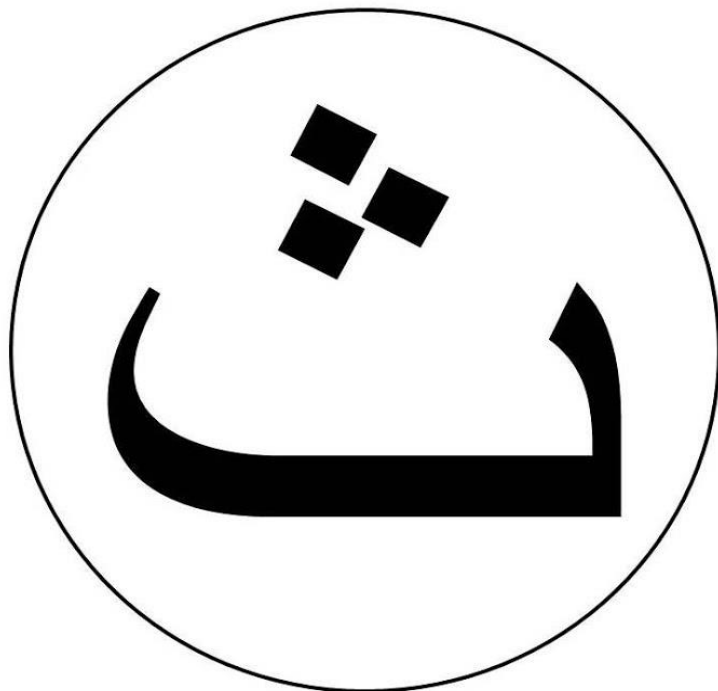
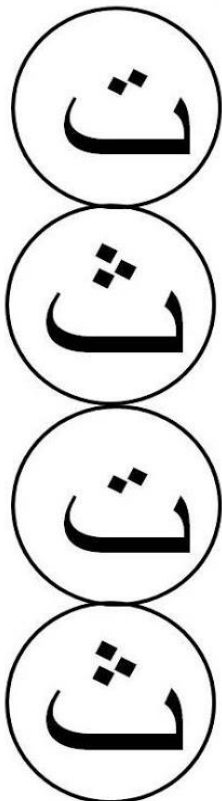
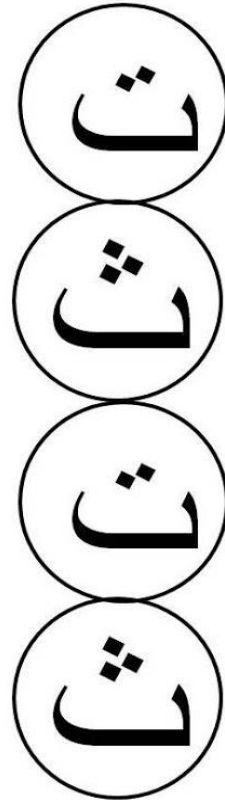
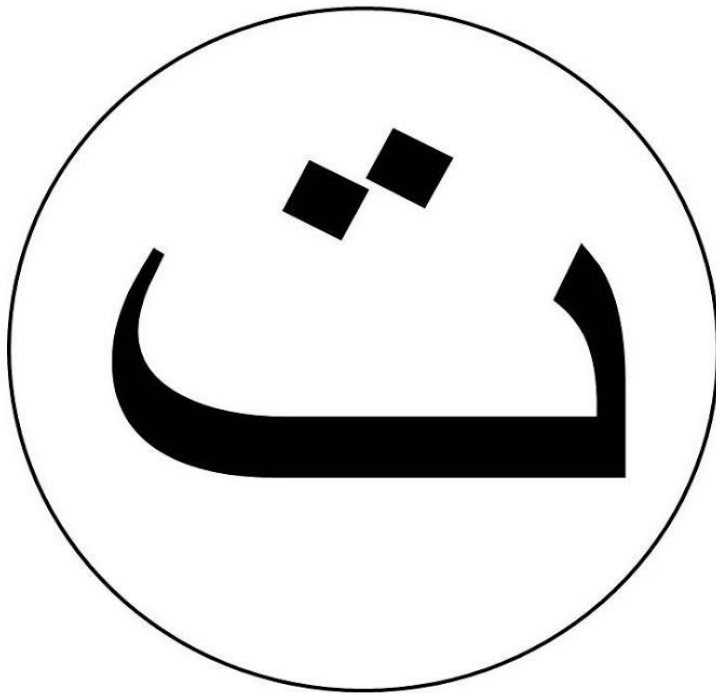

EXERCISE 76: IDENTIFY THE LETTERS

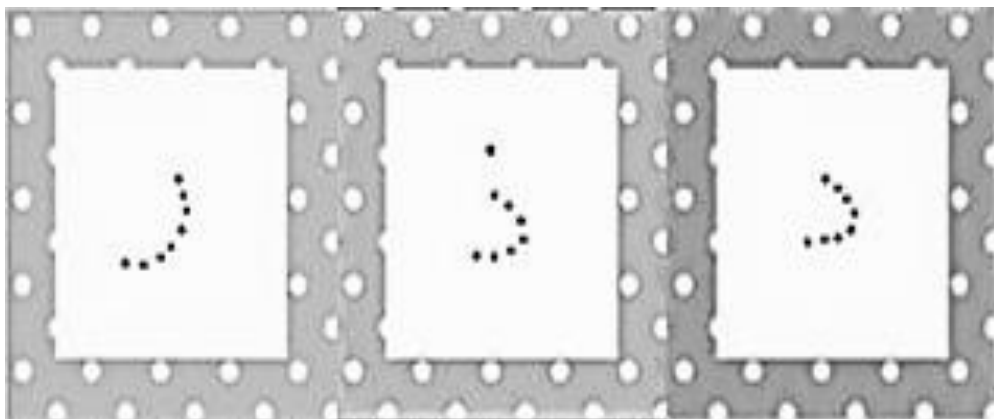
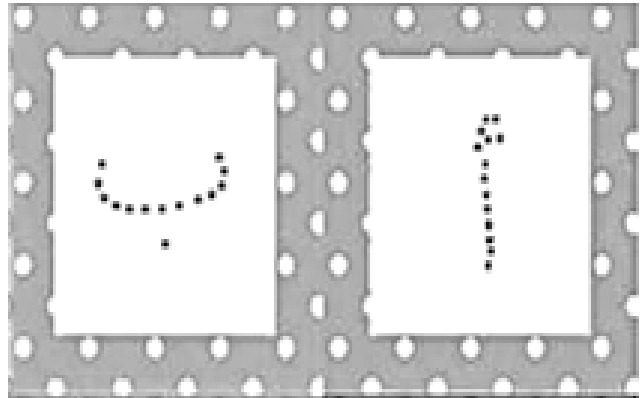

EXERCISE 77: READING ALPHABETS ALIF - RE

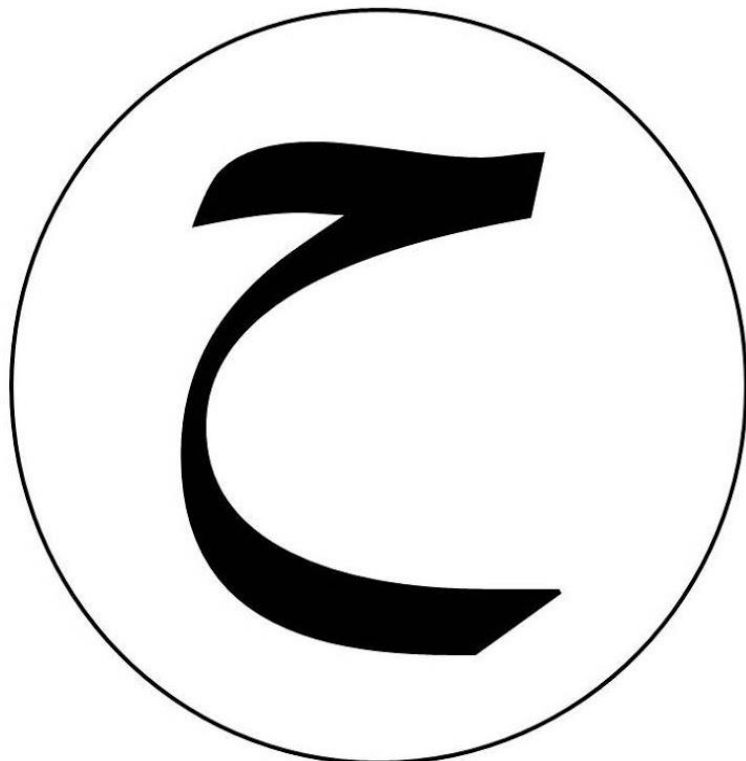
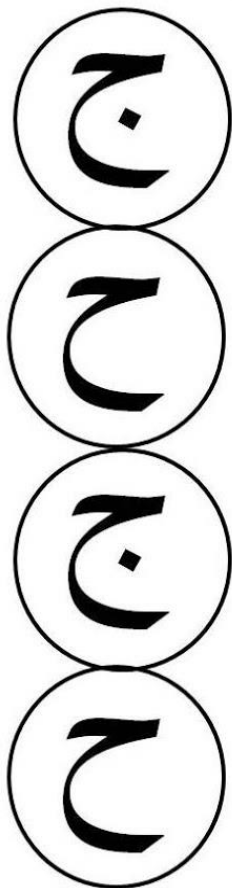
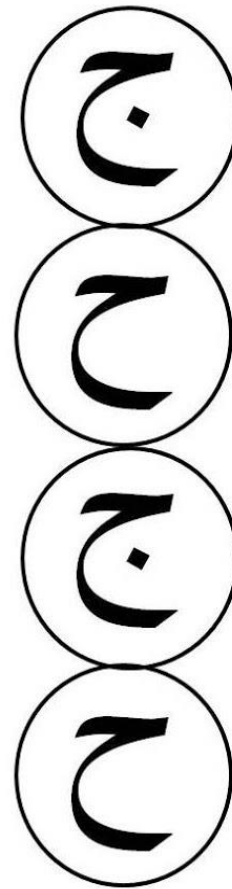
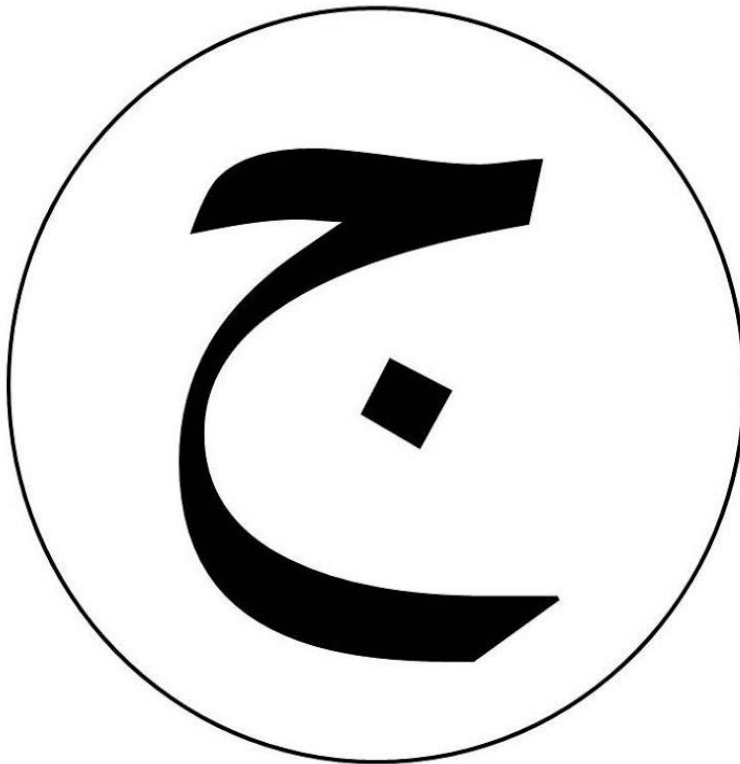

EXERCISE 78: IDENTIFY THE LETTERS

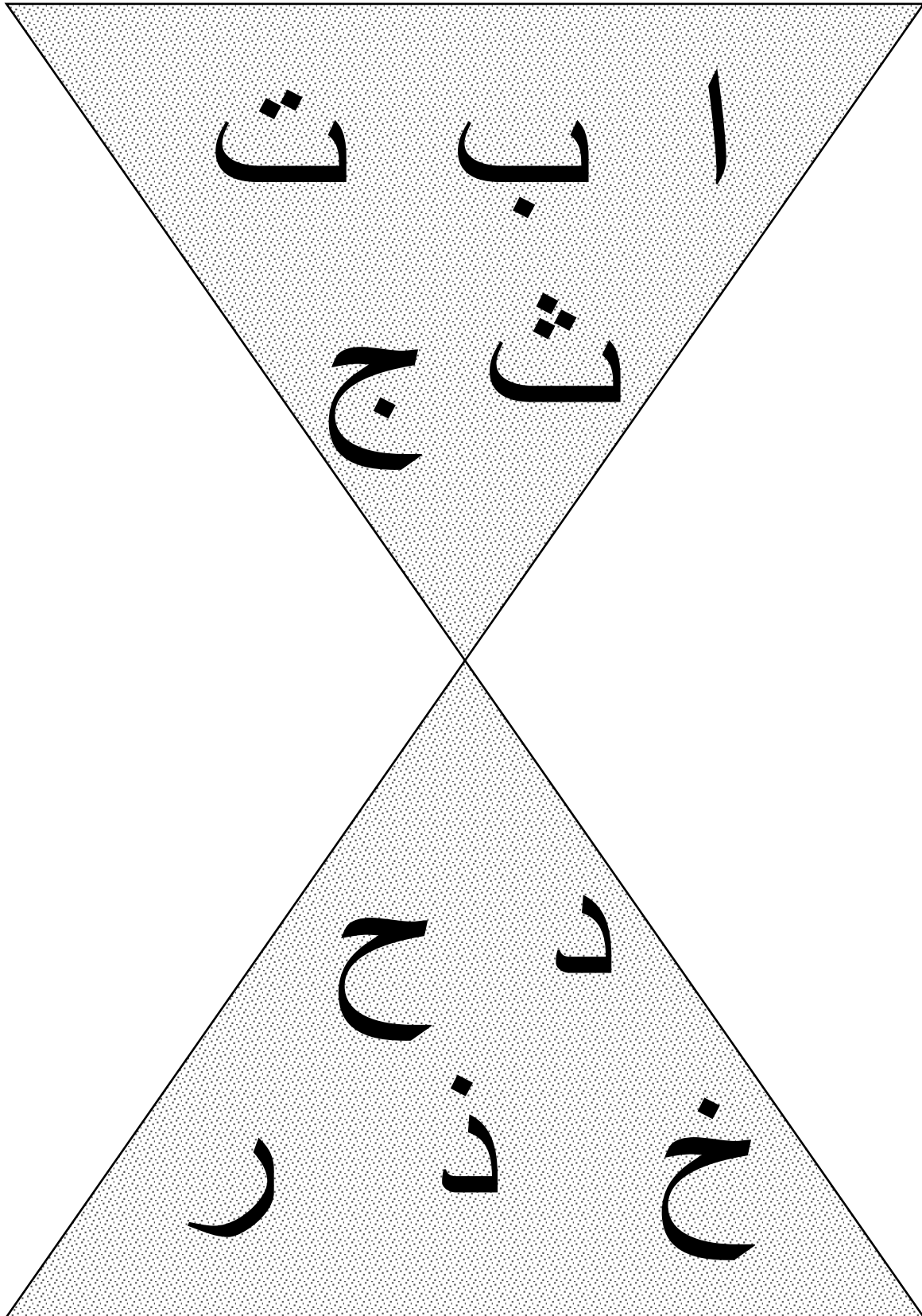

EXERCISE 79: READING ALPHABETS ALIF - RE

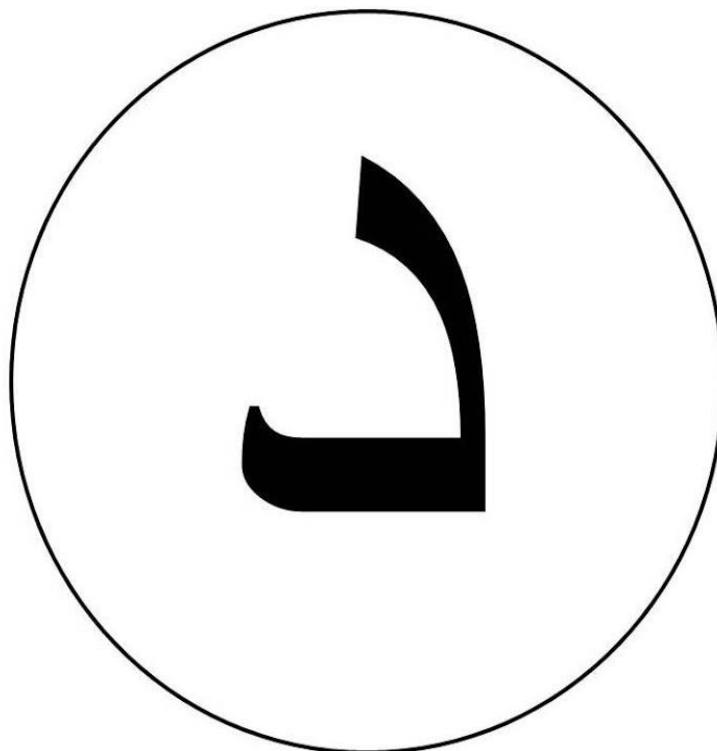
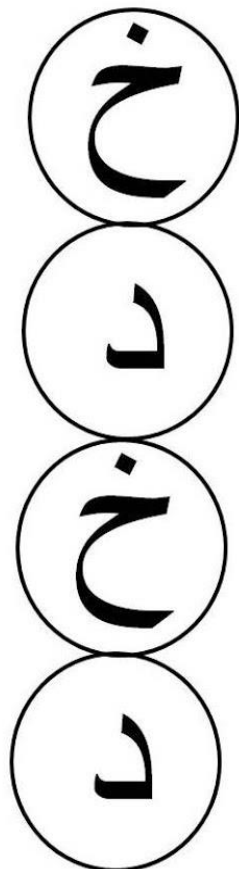
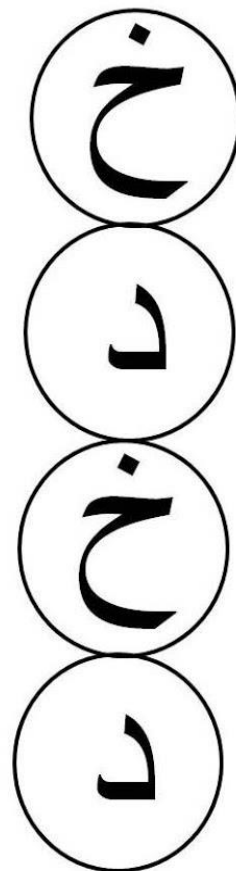
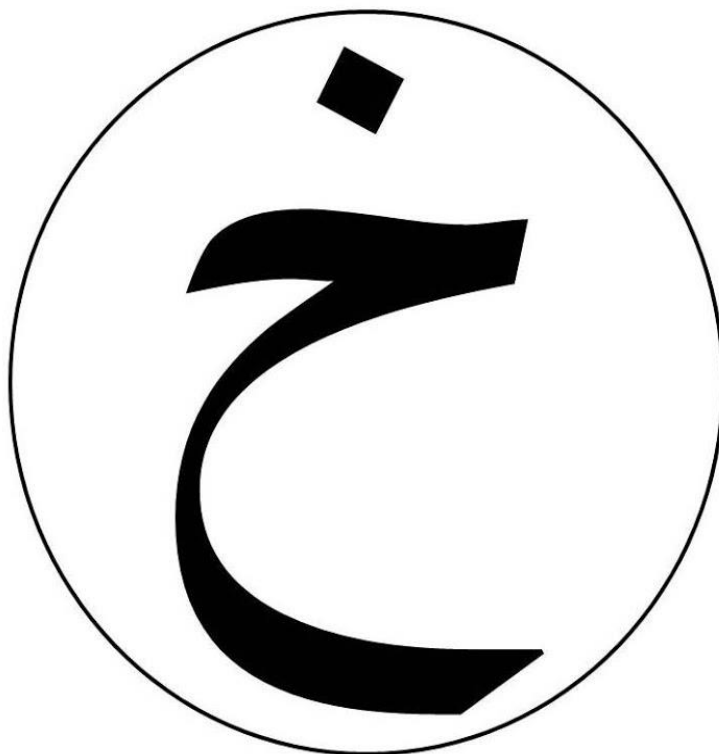

EXERCISE 80: IDENTIFY THE LETTERS

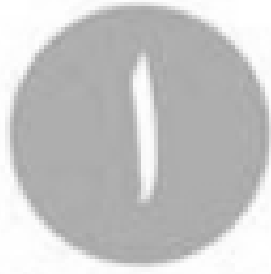

EXERCISE 81: READING ALPHABETS ALIF - RE

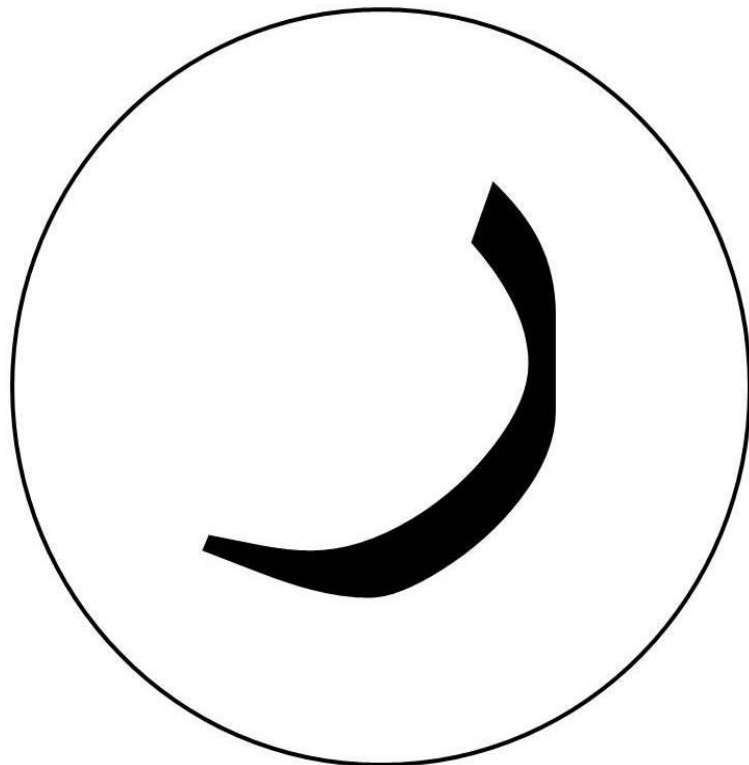
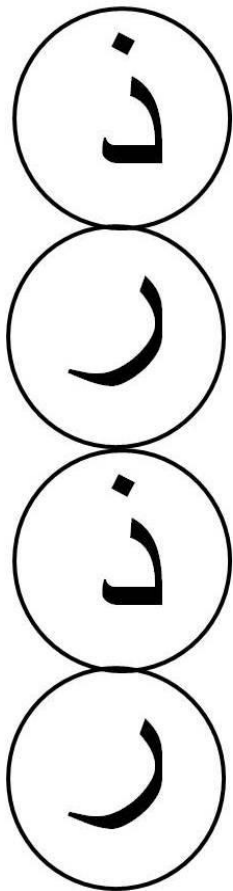
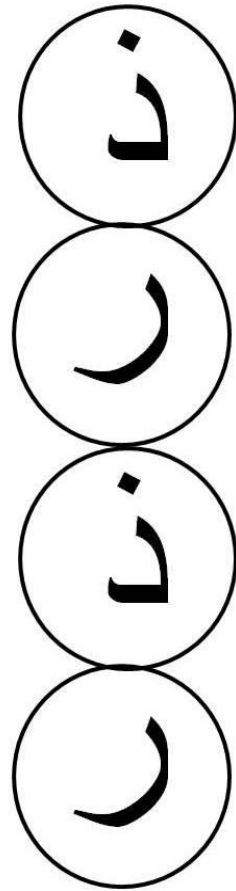
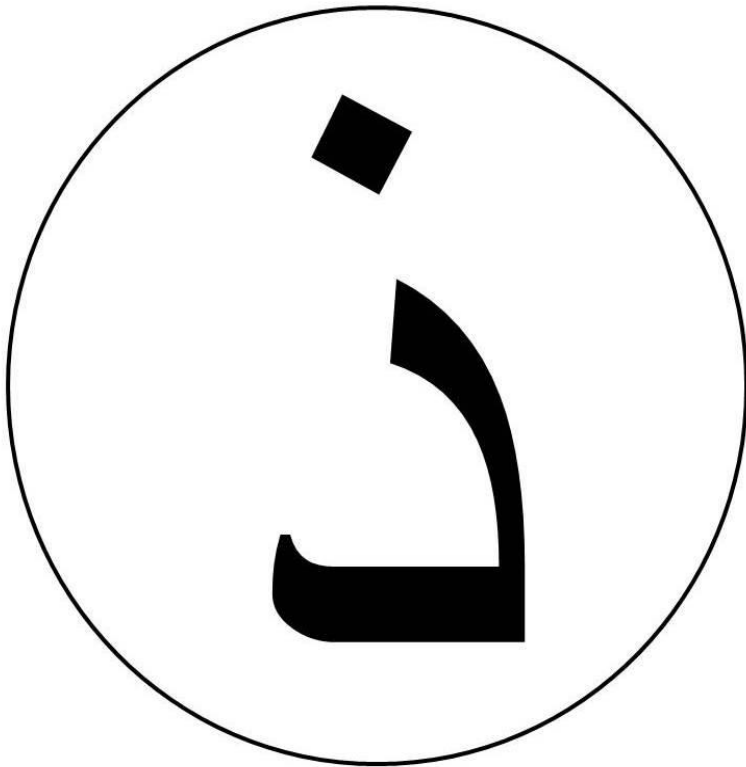

EXERCISE 82: LETTER RECOGNITION

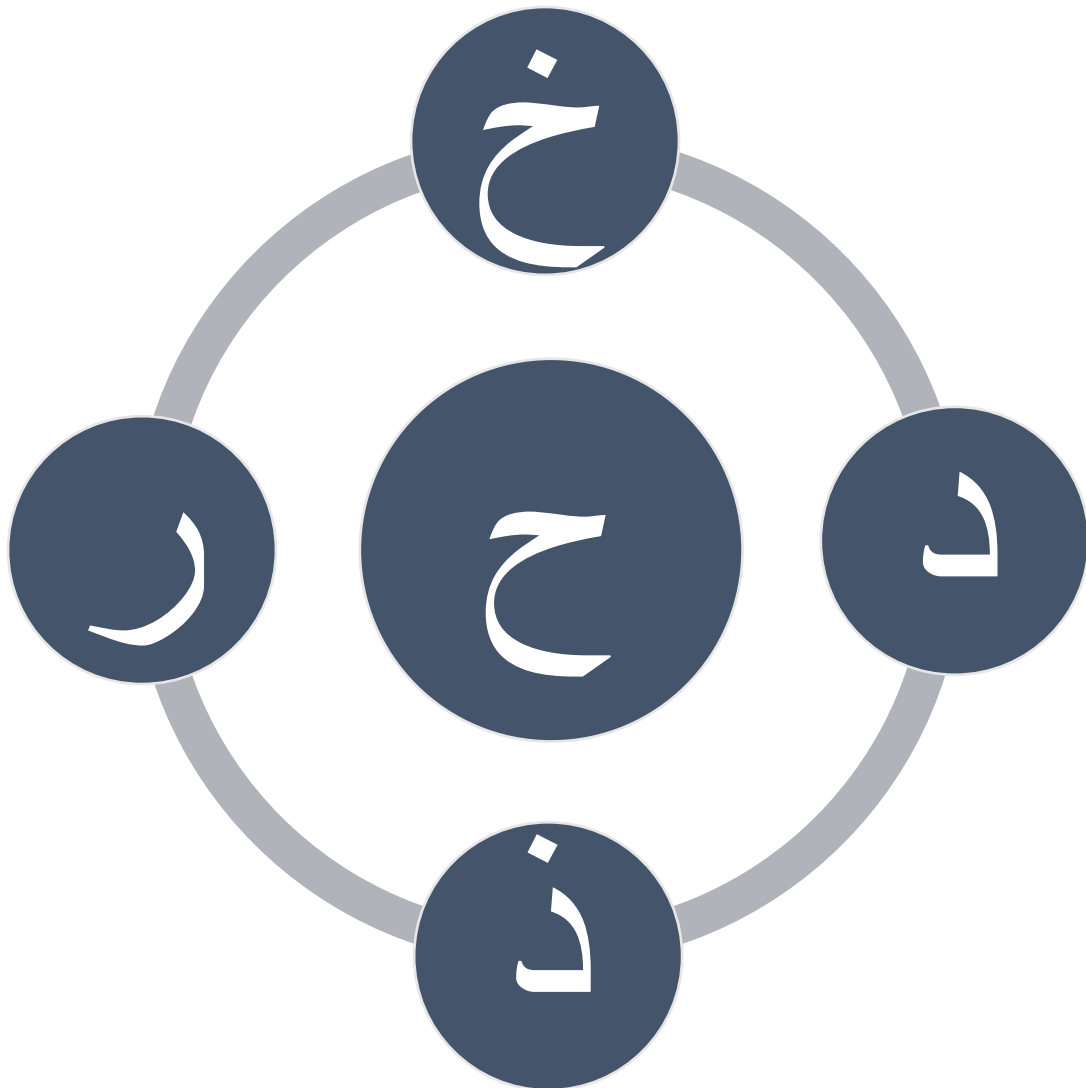

EXERCISE 83: IDENTIFY THE LETTERS

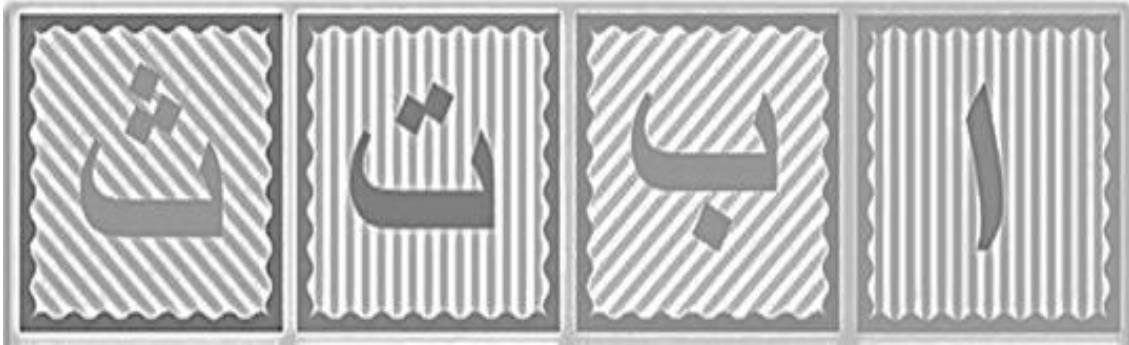

EXERCISE 84: IDENTIFY THE LETTERS

